

A grid of colorful buttons (green, white, red, brown) with various medical and anesthesia-related terms printed on them. The terms include: PROPOFOL FREE INDUCTION, FENTANYL, ROLL AGAIN, BUPRENORPHINE, NO RELAXANT, MORPHINE, DES, ETT, BLOCK SOMETHING, OTHER LMA, ISO, SUPREME, NO RELAXANT, CLASSIC, OXYCODONE, VIDEO LARYNGOSCOPE, CHEAPEST OPTION, IGEL, YOUR CHOICE, O2/AIR, NO RELAXANT, OTHER LMA, TRAMADOL, PROPOFOL TCI, MORPHINE, SUPREME, BUPRENORPHINE, N2O, OXYCODONE, PROPOFOL FREE INDUCTION, MORPHINE, DES, YOUR CHOICE, BLOCK SOMETHING, ETT, SEVO, FENTANYL, ROLL AGAIN, VIDEO LARYNGOSCOPE, ISO, and NO RELAXANT, OXYCODONE, CHEAPEST OPTION, TRAMADOL.

THE FIRST YEAR

What you should know after a year of anaesthesia training

LACHLAN RATHIE

Acknowledgements

Thanks to all the registrars and junior doctors who have worked in my Department over the years for the opportunity they have given me to both teach and learn from them.

Thanks to all those people who have said over the years, “You should write a textbook.” Now I can say that I have done so.

Thanks to my colleagues for their comments and insightful feedback.

Thanks to Barb Lindbergs for permission to use the Anaesthetic Machine check documents and for access to her costing spreadsheets.

Lastly I would like to thank my wife who inspires and tolerates me.

I welcome any comments, criticism or vitriol and they can be conveyed to me at ltrathie@bigpond.net.au

Lachlan Rathie
Toowoomba
April 2016

Disclaimer

Every effort has been made to ensure the information contained within this book is accurate and correct; especially with regard to drug dosages. Despite this, errors may have been made and advances or changes in medical science and practice may render some information incorrect or incomplete. Current drug product information monographs are the most reliable source of prescribing information.

TABLE OF CONTENTS

Setting the scene

A bit about the structure of this book	7
Why have I written this book?	9
Common errors made by trainee anaesthetists.....	12
Curriculums.....	13
What you should be able to do after a year.....	15
Resources	17
How to learn anaesthesia	21

Tools of the Trade

Monitoring- all those pretty waveforms	25
The Electroencephalogram and Its Application to Anaesthesia.....	32
The Anaesthetic Machine	45
The White Stuff.....	53
Thiopentone and Ketamine	63
Volatile Agents and Nitrous Oxide.....	68
Muscle Relaxants and Reversal	84
Analgesics, Antiemetics and Local Anaesthetics.....	98

The Main Event

Preoperative Assessment	108
Planning the Anaesthetic	127
The IV and drawing up drugs	132
Induction of Anaesthesia	138

Maintenance of Anaesthesia.....	144
Emergence	151
How to do a spinal (& an epidural).....	156
Everything you should know about Propofol TCI.....	168
Putting it all together- Example Cases.....	177
Special Situations	
Obstetric Anaesthesia.....	185
Paediatric Anaesthesia	201
The Obese Patient	209
A few words about endoscopy.....	218
Crises in a Nutshell	
Difficult Airway 101	222
Hypoxia	236
Hypotension	240
High Airway Pressure.....	243
Perioperative Medicine	
Studies you should probably know about	248
Antithrombotic Drug Management	253
The bleeding patient and transfusion therapy	257
Making a Difference	268
Miscellany	
My Top Twenty Tips.....	276
The Cost of Things.....	277

Preparing for the Primary Examination	279
Pre-Questionnaire	283
Initial Assessment of Anaesthetic Competence- example paper	285
Midyear Checklist for Meeting with Supervisor- JCCA	288
My Other Books	290

A bit about the structure of this book

This book is arranged into seven sections. The first section endeavours to explain why I have written this book. It outlines the existing deficits in the textbook literature, the shortcomings in trainee knowledge I have witnessed firsthand and the errors that have resulted. The two curriculums pertaining to anaesthetic training in Australia are briefly described as well as their practical implications. I have listed what skills and attributes that are both likely and necessary to be gained after a year of anaesthetic practice. The best available resources are reviewed to inform practitioners of their value to the learner anaesthetist and perhaps help you decide whether to buy any of them for your personal library. Finally are some thoughts about how to learn anaesthesia.

The second section, 'Tools of the Trade', gives some detailed core information about the integral tools of our profession- namely our equipment with a focus on the anaesthetic machine and patient monitors and the drugs with a focus on the important anaesthetic drug classes. A common theme in the book is to expressly focus on pragmatic but core knowledge that is required to conduct anaesthesia safely but is lacking or hard to find in conventional learning resources. At the end of some of the chapters in this section and the next four are up to three separate items. The first of these are selected references. These are not exhaustive or definitive but references I feel worthy of reading in their own right by the junior anaesthetist. The second item comprises challenge questions relating to the content in the preceding chapter or chapters. The answers are on the following page. Some of these will even challenge your consultant! The third component that follows some chapters I collectively term 'light relief' and contains items of a humorous/ cynical/ sarcastic nature.

The third and largest section of this book I have dubbed 'The Main Event'. This relates to the actual conduct of anaesthesia and is further subdivided into chapters relating to preoperative assessment, planning and giving the anaesthetic. There is a detailed chapter about propofol TCI, a subject whose practical application is a lot better realized than an understanding of its theoretical foundation. Lastly is a section outlining in a stepwise fashion the anaesthetic management of some common cases. To an extent this synthesizes information from earlier chapters and applies it to example cases. The emphasis is very much on giving a practical and common sense foundation to what we do every day in the operating theatre. I believe you should critically appraise and be able to justify your practice and this section attempts to do just that.

The next section relates to the two main specialty areas of anaesthetics that all generalist anaesthetists practise in- namely obstetrics and paediatrics. Again common errors and deficits are addressed as well as practical considerations for safe practice. A chapter is devoted to the most significant challenge of our professional lives- obesity. Finally are some thoughts about the commonest procedures performed that require anaesthetic services, namely endoscopy.

The fifth section relates to crisis management. There are many good resources on this subject (including one I wrote) so I have restricted this section to the three commonest crises encountered intraoperatively: hypoxia, hypotension and high airway pressures. Airway crises

feature prominently in the anaesthesia canon so the section commences with a discussion regarding difficult airway management.

The next section relates to aspects of perioperative medicine. This is a very large component of contemporary anaesthetic practice and I have restricted myself to the more common issues that anaesthetists have to deal with on a daily basis. This is an element of practice which is informed to a degree by an evidence base. Consequently I have tried to highlight the important studies of relevance as well as making the trainee anaesthetist aware of the multiple situations where there is a lack of quality evidence to inform practice. My personal perspective on how we as anaesthetists can make a difference to important perioperative outcomes is succinctly outlined.

Finally, in the aptly titled 'Miscellany' section is an assortment of topics. A list of the cost of commonly used anaesthetic drugs and consumables is included for your consideration. Cost efficiency is an important attribute of the contemporary anaesthetist. Most anaesthetists in their first year are contemplating if not studying for the primary exam so my personal thoughts about how to tackle this life defining event are included for your consideration. An example of the IAAC (Initial Assessment of Anaesthetic Competence) exam I give my trainees is reproduced. This serves as an indicator of the level of knowledge you should possess after approximately six months on the job. Lastly, if you enjoy my 'light relief' items there's a blurb about my two 'other' books most of the items came from: *The Anaesthetist's Companion* and *The Cynical Anaesthetist*.

Why have I written this book?

My predominant anaesthetic interest pertains to educating the next generation of anaesthetists. My credentials that demonstrate this are my role as the Supervisor of Training (SOT) of anaesthetic trainees in a large regional hospital. I am also a primary examiner for the College of Anaesthetists. Prior to becoming an anaesthetist I was a rural general practitioner (GP) in South Western Queensland and completed a Fellowship with the College of General Practitioners as well as a Graduate Diploma in Rural General Practice and a Diploma in Obstetrics and Gynaecology. My first real exposure to anaesthesia was my advanced skills year of anaesthetics that I did as a component of my rural GP training. I essentially decided to pursue anaesthesia as a career because I enjoyed giving anaesthetics more than consulting. I also like the academic and professional challenges that the specialty provides. I became an examiner because it appeals to the academic snob in me and because I consider it the defining element of our training and it reflects the high level of training that Australasian anaesthetists receive. I am inherently biased but I think Australasian anaesthetists are the best in the world and I want to contribute to maintaining that proud record.

I am a bit of a textbook junkie and have accrued quite a large collection over the years. The vast majority of texts are an expensive disappointment. Common themes of disappointment are outlined below:

- Overt American or UK flavour
- Out of date
- Can't find 'exam' answer
- Inadequate explanation of fundamental concepts
- Unreadable, boring, dry
- Nothing 'new'
- Patchy coverage of topics
- No practically useful information

The last disappointment detailed above is the biggest crime- the answers to practical questions regarding how to anaesthetize the patient I have in front of me are invariably not found in books. Try and find in a textbook the answer to the following questions:

- What are the criteria for extubation?
- What is the intubating dose of rocuronium in a patient who weighs 150kg?
- How do I interpret a post tetanic count?
- How long does the patient have to be off Rivaroxaban/ Dabigatran/ Prasugrel before I can do a spinal?
- Do platelets/ FFP need to be ABO compatible?
- How do I manage a LMA with a leak?
- What's the point of giving Midazolam on induction?
- Should I use a cuffed tube in a 4 year old?
- When do I cancel a kid with an URTI?
- How do I intubate someone without muscle relaxants?

- Does oxycodone have any clinically important benefits over morphine?
- Do I have to abandon my anaesthetic machine if there is a power board failure?

You may find the answer to a few of these questions in one of the College recommended texts but I guarantee you won't find the answer to *all of them* in one book. One of the great frustrations experienced as a trainee is having to search through a whole series of resources to find the answer to a simple clinical question. Knowing where to look comes from experience. If nothing else I hope this book saves the prospective anaesthetist from a lot of fruitless searches.

Specialty textbooks abound as do exam primers. Books written for the beginner anaesthetist are relatively uncommon and all suffer from the same problems: they are aimed at the medical student or resident as opposed to the trainee anaesthetist and they do not address the fundamentals in enough detail. As books of pragmatic value they are found wanting. There is no real book that fills the gap between medical student knowledge and anaesthetic specialty textbooks. By their very nature the latter are generic and assume knowledge of fundamental aspects of practice. The recommended reading list for the primary examination comprises a series of science texts (physiology and pharmacology) and American anesthesiology textbooks. There is little to assist the anaesthetist coming to grips with the bread and butter task of anaesthetizing reasonably healthy patients having common, unremarkable procedures despite this accounting for the majority of our practice. You can reasonably argue that the bulk of this knowledge is accrued using the apprenticeship model (more on this in the chapter *How to learn anaesthesia*) and I would agree with you. The experience as an apprentice is very variable. I have written this book to *consolidate* and *explicitly detail* what knowledge you should accrue in your first year of practice.

As SOT I never fail to be distressed and amazed at what stuff trainees don't know. A short list is detailed below- these are all consistent deficits. I don't understand how they can be giving anaesthetics safely with fundamentally inadequate knowledge informing their practice. Indeed the next section details a list of errors that I have witnessed recurrently over the years as a supervisor. Some of these relate to knowledge deficit.

- Intubating dose of muscle relaxants and how long to wait
- Effect site onset of action times for midazolam and the members of the fentanyl family
- Cost of drugs you draw up every day
- The perioperative risks that are directly attributable to anaesthesia
- Physiological effects of a pneumoperitoneum
- Differentiating an awake from an 'asleep' EEG waveform
- Assessing reversibility and managing a TOFC of one or less
- Strategies for managing suboptimal supraglottic airways
- Practical pharmacology of uterotonic drugs
- Relating MAC and propofol effect site concentrations to pharmacodynamic correlates

This book attempts to contain that missing knowledge, to fill the gap, so mistakes like those listed on the following page don't occur. This alone is not enough, though. I also want this book to challenge and entertain. I intend for it to contain items that will appeal to the whole spectrum of anaesthetic practitioners: from medical students through to consultants as well as anaesthetic assistants.

Common errors made by trainee anaesthetists

- Didn't assess the airway before rendering patient apnoeic.
- Didn't remove patient's partial plate (as they didn't know it was there).
- Didn't check whether IV actually working before injecting white stuff into it.
- Didn't check whether patient had had their regular medications.
- Didn't check whether patient had a group and hold.
- Chose a LMA for a known difficult airway and then found it didn't work.
- Forgot to give long acting relaxant after the sux which has now worn off and patient is bucking on the tube.
- Forgot to turn on the smelly.
- Proceeded with a case and the LMA was never quite right.
- Didn't put an arterial line in and spent whole case chasing the blood pressure.
- Couldn't get spinal in because patient was never in correct position for a start.
- Didn't test regional anaesthetic before letting surgeon plunge in the scalpel (this is very poor form).
- Let surgeon tuck both arms out of reach and now can't sort out the pulse oximeter, IV and NIBP when they all take their turn to malfunction.
- Running the anaesthetic to the BIS monitor.
- Having a bad plan from the start.
- Putting a 130kg man with 3 fangs and a beard off to sleep and expecting to be able to bag mask ventilate them.
- Re-capping needles.
- Not auscultating after intubating.
- Forgetting left lateral tilt for obstetric cases.
- Putting a pile of pillows under the patient and still failing to improve the intubating position.
- Turning the smelly off in a patient spontaneously breathing on a LMA and there is no anaesthetic assistant or trolley to be seen.
- Drawing up ephedrine and metaraminol for every case.
- Transfusing someone because they 'want' a [Hb] of 10.
- Treating hypertension resulting from a pneumoperitoneum or tourniquet with opioids.
- Never learnt proper aseptic technique.
- Not knowing what the operation entails or how long it will take.
- Not asking for help.
- Not listening to the patient.
- Assumed the surgeon knows what they're doing.

Curriculum

There are two curriculums that detail the knowledge, skills and attitudes the trainee anaesthetist should attain in their first year. They are the ANZCA Training Program Curriculum which can be accessed freely from the College website and the JCCA (Joint Consultative Committee on Anaesthesia) Curriculum which is for general practice trainees doing an advanced skills post in anaesthesia. The JCCA curriculum is a joint venture with ANZCA, RACGP and ACCRM and can also be accessed online. The ANZCA curriculum was extensively revised and essentially rewritten a few years ago. The JCCA curriculum was last revised in 2010 but there were few changes evident in its content from the previous edition.

I will consider the ANZCA curriculum first. It is an impressive and remarkable body of work which was formulated as a response to an extensive review of anaesthetic specialist training undertaken by the College. The curriculum handbook details explicitly in a series of learning objectives exactly what knowledge, skills and professional attributes are to be achieved in each phase of training. Anaesthetic specialist training is five years fulltime- an initial six months of Introductory Training (IT), 18 months of Basic Training (BT), two years of Advanced Training (AT) then a Provisional Fellowship (PF) year. Assessment requirements bridge each of these sections and must be passed before progression to the next stage, i.e. IAAC (initial assessment of anaesthetic competence) after IT, primary exam after BT, final exam after AT. So in the first year the IAAC must be completed successfully and most trainees are actively studying for the primary examination.

The content of the curriculum is divided into sections known as the clinical fundamentals which have learning objectives throughout training. They are:

- Airway Management
- General anaesthesia and Sedation
- Pain Medicine
- Perioperative Medicine
- Trauma, Resuscitation and Crisis Management
- Safety and quality in anaesthesia
- Local and regional anaesthesia

As well as these there are specialized study units (SSU) that deal with the surgical subspecialties eg, obstetrics, paediatrics, neuroanaesthesia. I won't consider these further. Trainees interact with a web-based portal, the Trainee Portfolio System (TPS), which acts as a record of their training and all assessment activities. Apart from the big two exams the college assesses trainees with an extensive assortment of workplace based assessments (WBA) which are mandatory. The WBAs consist of the following types:

- MiniCEX- clinical examination exercise
- CbDs- case based discussions
- DOPS- direct observation of procedural skills
- MSF- multiple source feedback (aka 360 degree feedback)

For each section of training and each SSU and each clinical fundamental there are a series of WBAs to be completed. In addition to this there are mandatory volume of practice (caseload) requirements to be logged as well as assorted scholar role activities. I will focus on the IT and BT periods of training and the IAAC and primary exam which are the 'big ticket' assessment items. Both exams are a combination of written questions and vivas. In indexes three and four of the curriculum document it correlates learning objectives with each component of these exams. **This is as good a summary of the core knowledge expected of the trainee anaesthetist as you will find in the world.** I won't reproduce the indexes here but commend them to you. Of course the curriculum document does not detail or describe this knowledge; it just lists the learning objectives.

The mandatory WBAs for IT period of training are listed below and are all quite straight forward.

- DOPS- Can't intubate, can't oxygenate scenario; check an anaesthetic machine; bag mask ventilation and insertion of LMA; rapid sequence induction and extubation.
- MiniCEX- airway assessment, management of patient in acute pain, conduct of anaesthesia for well patients undergoing routine procedure.
- MSF- which I find is unhelpful ('Dr X is very nice...')

Completing WBAs is not difficult, acquiring and applying clinically important knowledge as it pertains to anaesthetizing patients is the tricky bit. The main benefit of WBAs is they afford a mechanism for feedback throughout training. The quality of the feedback is the crucial factor, here. So the anaesthesia training program curriculum is a detailed and impressive document but doesn't detail the content it expects you to know (nor do I expect it to).

The JCCA curriculum document is much shorter and less detailed. It doesn't broaden or extend the ANZCA curriculum and is an unhelpful document in practice. The assessment process is less proscriptive, not as multi-faceted and less difficult, of course. How JCCA trainees are assessed and managed varies in each training location. I think this is the program's greatest weakness. For this reason I manage advanced skills post GP registrars, rural generalists, PHOs and others doing terms in anaesthesia (emergency medicine and ICU registrars) as if they were introductory trainees and subject them to similar assessment exercises.

What you should be able to do after a year

Independently* anaesthetized patients having the following procedures:

Endoscopy- Gastroscopy and Colonoscopy

Obstetrics- Emergency and elective LSCS, retained placenta, EUA for PPH.

Gynaecology- D&C/ Hysteroscopy, vaginal and abdominal hysterectomy, laparoscopy, vaginal repair.

General surgery- appendicectomy, laparoscopic cholecystectomy, hernias, laparotomy, skin excisions, draining abscesses.

Dental anaesthesia

Orthopaedics- ORIF long bone fractures upper and lower limbs, MUA fractures, arthroscopy, carpal tunnel release.

Depending on your hospital's caseload and your exposure it may also be reasonable to include minor cases from some other surgical specialties eg. Urology, ENT, Maxillofacial as well as limited paediatric cases especially orthopaedic trauma.

*This means you did the case yourself- planned, conducted and took responsibility for it- regardless of the level of supervision. (There's Level 1 and there's Level 1!)

Skills you should be able to competently and independently perform:

- Bag mask ventilation- the single most important skill you will accrue, refine and maintain.
- Spinal, epidural and combined spinal epidural anaesthesia.
- Obstetric Epidural analgesia.
- Insert LMA of all types- first and second generation; intubating LMA; reinforced.
- Intubation using conventional and less conventional blades as well as being proficient with every videolaryngoscope your Department possesses.
- Set up an IV line and manage an IMED pump.
- Program a PCA and epidural pump as well as propofol TCI.
- Perform a level 2 check on every anaesthetic machine you use.
- Insert arterial line (using a humble IV cannula) and rapid infusion cannula.
- Insert central line by femoral and jugular routes (preferably not being totally reliant on an ultrasound to achieve this).
- Gas induction of children as well as adults.
- How to do TIVA for children.
- Insert a nasogastric tube without the use of a laryngoscope or Magills forceps and creating torrential epistaxis.
- Do a femoral nerve block.
- Be familiar with basic knobology on an ultrasound machine.
- Conduct intravenous regional anaesthesia (a rarity in contemporary anaesthesia).
- Describe and demonstrate exactly how you would do a surgical airway and oxygenate a patient if you had to.
- Prescribe the following:

- Bridging regimen for someone on warfarin
 - Perioperative Insulin infusion and regimen
 - Postoperative analgesia and fluid orders
- Rationally order and interpret common clinical investigations including ECG, blood gases and radiology.
- Be intimately familiar with all of your hospital's information management systems-automated anaesthetic record, theatre data management, pathology and radiology.

Resources

Undoubtedly the best resource is an experienced practitioner who is keen to teach. If they are a gifted teacher who inspires and enthuses you then you are a lucky person indeed. Most people aren't like that, of course. There is an abundance of learning resources available for the anaesthetist in training. I will not consider exclusively online resources as most are freely available and the vast majority have an exam focus. I contend you do not get a solid grounding in core clinical knowledge solely from the internet. Wikipedia can certainly answer most questions, but not all. The core knowledge in this book should become second nature to you and be located firmly in the forefront of your hippocampus. Many of the resources I have listed below are available to access via the College e-library. Quite a few can be downloaded in their entirety to access when offline. It is worth perusing the list of available titles. The value of the ANZCA Training Program Curriculum was detailed in the preceding section. It details what you should know.

Textbooks

Anaesthesia is essentially applied pharmacology and physiology so books relating to these two topics constitute the foundation of the trainee anaesthetist's core knowledge.

Anaesthesia: An Introduction, edited by I Harley and P Hore, 5th edition, 2012- this is essentially a collection of lecture notes by Victorian anaesthetists compiled into a book. Despite the recent publication date it is a bit dated and suffers from lacking detail in crucial areas as they relate to the safe practice of anaesthesia. It's okay.

Anaesthesia Made Easy- a UK book now in its 4th edition. Quite well set out and mercifully brief it still suffers the same problems as its Australian counterpart described above. *Introducing Anaesthesia* and *Basic Clinical Anaesthesia* are recently published books in a similar vein. They are all books for medical students and residents really.

Pharmacology for Anaesthesia and Intensive Care, Peck and Hill, 4th edition 2014. There is no ideal single volume text on anaesthetic pharmacology that tells you everything you need to know. There are a lot of books out there and they are mostly thick, unpalatable tomes. Peck and Hill is brief but enough detail for the First Year for most things. Its treatment of muscle relaxants, volatiles, propofol and TCI is still inadequate.

Stoelting's Pharmacology and Physiology in Anesthetic Practice, Edited by P Flood, J Rathmell and S Shafer, 2015- the latest fifth edition of this American text has a new editorial board and it is a big improvement over earlier editions. I think this is possibly the best single text out there for the core sciences but it is certainly lacking in terms of practical, real world application to anaesthetic practice.

Perioperative Medicine for the Junior Clinician edited by J Symons et al., 2015. This is a contemporary book written by Australian authors that is nicely set out with weblinks to video clips and case commentaries. It is based on the Perioperative medicine short course run out of Monash University and affiliated with the Alfred Hospital in Melbourne. Unfortunately, as the title alludes, it is written for junior clinicians and is really resident level stuff. In terms of a reference for practical management of specific cases and diseases it falls flat as it is too light on. I was very disappointed when I bought this book as I was hoping it replicated the course.

Westmead Anaesthetic Manual, Anthony Padley, 4th edition 2015. This is an alphabetically arranged compendium of a whole series of brief vignettes relating to anaesthetic topics. Its main benefit is as a practical aide to guide clinical management- eg look up dose of a drug, look up algorithm for specific crisis or problem management, specific diseases eg myasthenia gravis, anaesthetic complications, regional blocks. All these things can be accessed on your device too but it is a nice, compact, regularly revised book authored by an Australian anaesthetist. I would recommend Padley over the Oxford Handbook which a lot of trainees have. Neither functions as a text to confer core knowledge. I see a lot of trainees carrying the Oxford Handbook around but not actually looking anything up in it.

Gerry's Real World Guide to Pharmacokinetics and Other Things, Gerald Woerlee, 2008. A brilliant book that is the most palatable way you will ever learn about a very dry topic like pharmacokinetics which is fundamental to understanding applied pharmacology. Written by a Dutch anaesthetist, this book is brief at 180 pages and entertaining. I highly recommend it as a starting place to read about pharmacology.

Just Enough Physiology, James Munis, 2012. I think of this as the physiology equivalent of *Gerry's Real World Guide*. It is similarly brief, brilliantly written and entertaining. Written by an American anaesthesiologist it deals with core concepts of clinical measurement, cardiovascular and respiratory physiology. The book's great strength is it elegantly explains fundamental physiological concepts before applying them to concepts of interest to the trainee anaesthetist. There is no equivalent of its type on the market. I am particularly fond of Chapter 4 'Doctor Dolittle Visits a Sitting Case' which uses the giraffe to illustrate concepts about siphons and cerebral perfusion pressure. I highly recommend this book as an initial read before embarking on more detailed specialty texts like the next book to be discussed.

Nunn's Applied Respiratory Physiology, Andrew Lumb, Seventh edition 2010. Anaesthetists are especially interested in the heart, lungs, brain and kidneys. If there was one organ to focus your efforts on in terms of reading a textbook about it then I would nominate the lungs. Respiratory physiology constitutes the single largest chunk of physiology in the curriculum and is core to our practice. It is also arguably the more difficult subject to understand at a conceptual level. Cardiovascular and neurophysiology are relatively straight forward whereas a disarmingly simple book like West's *Pulmonary Physiology* belies the fact that there are a lot of concepts that are quite hard to grasp an understanding of. Nunn is the Bible of respiratory physiology and I think it is worth getting yourself a copy. The chapter pertaining to anaesthesia is essential reading.

As I have alluded there is no great clinical anaesthesia textbook for the trainee anaesthetist but you might consider getting one of the following:

Clinical Anesthesia Fundamentals edited by Barash et al and Morgan and Mikhail's *Clinical Anesthesiology*.

Acute pain management accounts for a considerable portion of the junior anaesthetist's workload. Undoubtedly the best text that specifically addresses this content is Macintyre and Schug's *Acute Pain Management- A Practical Guide*. The fourth edition was published in 2015. I still find it wanting with regards to specific details about drugs and it doesn't make managing the difficult patient any easier!

Finally a word about *Miller's Anesthesia* which is now in its eighth edition. It is still regarded as *the* anaesthesia textbook and the chapters are written by eminent, highly regarded authors. There is an awful lot of great information in there but it is very thick, expensive and difficult to assimilate especially as a learner anaesthetist. It suffers from the perennial problem of failing to

translate this knowledge to clinical practice. It is still the reference text I would use to look up a specific topic in an attempt to get a definitive answer.

ANZCA Website- Networks

This resource which was launched in 2015 is constantly evolving and incorporates a large number of resources aimed at trainees of all grades as well as their supervisors. There are links to numerous guidelines, College Professional Documents and a host of other resources. Probably the best resources are the podcasts but they are necessarily incomplete and patchy in their coverage. Their value largely stems because they are given by practising clinicians who also supervise junior trainees so they are both informative and pragmatic. There is a lot of excellent material relating to preparation for the primary and final exams.

Courses

I don't consider any courses mandatory in your first year apart from an in-house ALS course. You are learning on the job with the best resource: actual patients.

Having said that there is a plethora of courses out there and they all have their benefits. There are a host of emergency medicine courses, advanced life support, critical care skills, rural and remote medicine workshops, ultrasound workshops as well as the big ticket items like EMAC. They are all expensive and most have significant waiting lists. The EMAC, Early Management of Anaesthetic Crises and the ACRM, Anaesthetic Crisis Resource Management, are both 2 day courses run in a high fidelity simulation centre. I personally would not recommend these to an introductory level anaesthetist in training. I think all anaesthetists should do the ATLS, Advanced Trauma Life Support, also called the EMST, Early Management of Severe Trauma course. The benefit of the EMST course is that it is tightly structured; it teaches an approach that is universally adopted by practitioners the world around and it has an assessment component. The latter helps encourage understanding and adoption of the principles presented in the course. Multitraumas are managed by a mixed multidisciplinary group of clinicians. Everyone needs to be on the same page and have well defined roles. EMST clearly delineates these roles and the expected sequence of management steps. EMAC tends to focus on rare crisis scenarios in the actual simulation component and suffers from a lack of consistency in the core material used and how the course is run. Anaesthetists get regular exposure to crisis scenarios during the course of their practice- hypotension, high airway pressures, desaturation, bleeding- and they should be adept at managing these. EMAC is not where you learn this!

Putting EMST aside which is quite necessarily didactic, I believe you can gain a lot of benefit from in-house simulation based workshops using relatively low fidelity equipment. This is because the main benefit of these types of workshops is on improving team-working and communication skills preferably involving the actual personnel you work with in an environment as close to your own, i.e your theatre suite. An obstetric haemorrhage drill doesn't need a high fidelity model to facilitate optimizing your theatre's coordinated response to this common emergency which involves more than just the anaesthetic staff.

Others

Every anaesthetist needs ready access to a pharmacopeia of some sort- I have iMIMS on my iDevices and frequently refer to it to identify what drugs my patients are on. The most common indication to refer to a pharmacopeia is to work out what the actual drug is given a perplexing brand name. The other excellent resources are the *Australian Medicine Handbook* and *Therapeutic Guidelines*. Most hospital clinicians can readily access these resources online. Frank Shann's Drug Doses is a popular paediatric pharmacopeia that I have never had the need to consult as the above resources all have paediatric dosing guidelines. There are apps for all of these.

There are a host of apps with emergency management guidelines, dosing calculators, tube sizing etc. I think they are all useless because the calculations you make on a daily basis should be second nature and do not require an electronic device to perform. The dose of adrenaline for a paediatric arrest is 10mcg/kg IV. An adrenaline minijet is a 10ml ampoule of 1 in 10000 adrenaline. There is 100mcg in each ml or 1ml per 10kg bodyweight. This is the only drug in an arrest situation that you don't have time to look up the dose.

Finally I will put a plug in for my *Anaesthetic Emergencies Handbook*. This is a book I initially wrote for my hospital detailing the management of anaesthetic emergencies. It is a consultant grade level text and has been revised and expanded annually since the first edition ten years ago. There is now a generic version of the handbook. It is in a pdf file format and it is now freely available on the ANZCA website in the Library Resources section. Look under 'Training' in the Library Guides. The section on crisis management borrows heavily from this resource.

How to learn anaesthesia

This chapter is not intended as an erudite dissertation on educational theory. It is my personal opinion on how to get the most out of your first year. Medicine is traditionally learnt by the apprenticeship model. Anaesthesia is no exception and it very much lends itself to this style of learning. The majority of your training is spent working one on one with an experienced practitioner actually doing the job of anaesthetizing patients. There are some inherent problems with this arrangement compounded by the personality traits of anaesthetists- each supervising practitioner is the product of their own individual experiences. They have devised practices that work well for them. Anaesthetists are perfectionists and typically have strong opinions about what you should and should not do. These opinions aren't universal or necessarily correct. Personal experiences and anecdotes feature prominently in moulding our practice despite the lack of an evidence base because they invariably relate to highly stressful, emotionally charged episodes. The common socializing experiences of anaesthetists include sitting the primary and final examinations and being subjected to terrifying experiences in which you are acutely aware that you are responsible for keeping patients alive and patient harm can result if you do not execute your job well.

As well as knowledge, you need to acquire skills, both technical and non-technical, learn behaviours and be able to process and apply information in an appropriate, time efficient manner. The main formats of learning are:

- Book work
- Small group tutorials
- Workshops, simulation courses
- Learning on the job

I will focus on the latter. In terms of procedural skills there is no substitute for practice; doing the real thing again and again. Caseload is your friend. There is a steep learning curve for most anaesthetic skills. To gain a reasonable degree of competency only takes ten to twenty episodes of care. To gain proficiency in most of these skills requires hundreds of episodes of patient care. By the end of their five week anaesthetic term a resident can bag mask ventilate a patient, insert a LMA and intubate with a high degree of success. You should expect to be proficient in these skills and many more at the end of a year.

The adage that anaesthesia is 98% boredom, 2% sheer terror is quite correct. Similarly the oft used flying analogy- takeoff and landings being the exciting bits that bookend an otherwise boring flight- is accurate enough. It is very easy for you and your supervisor to 'switch off' to a degree once the patient is induced and you are in the maintenance phase of anaesthesia and thinking about your next tea break. I suggest this is the very time when a lot can be learnt. To get the most out of a learning experience you need to prepare beforehand.

This is my suggested approach:

- **Look at the list the previous day.** Look at the patient charts if available. Do you know what the operations entail- how long do they take, what position will the patient be in,

what is the expected blood loss, what surgical requirements are there? Does the patient have any co-morbidities or conditions that may influence the anaesthetic management? Are they taking a medication you don't recognize? What analgesic options are likely? At a minimum you should know what the operation involves and formulate an anaesthetic plan. If a plan has already been formulated then ask yourself why was that chosen? If the patient assessment is inadequate, unclear or not been performed then you need to rectify this.

- Decide on your goals for that list/ session. Be specific about what you want to achieve whether it is a skill or knowledge component, eg. I want to sort out perioperative diabetic management. Discuss this with your supervisor *before* you embark on the list. Determine how you will decide whether you have achieved your goal, eg. Write out a management plan for the next diabetic patient and discuss it with the attending anaesthetist.
- If all the patients are straight forward then consider trying something different with your supervisor's approval, eg. Using intubating LMA for a list of gynae laparoscopies. Take advantage of this protected environment to improve your skill base.
- If it is a long case- tackle one aspect of relevance. For example with a bowel resection some topics that could be discussed include: goal directed fluid therapy, physiological consequences of a pneumoperitoneum, postoperative analgesic regimens, enhanced recovery after surgery, cardiovascular monitoring and implications of chemotherapy.
- Every patient is different and has a different response to the drugs you give them and how they respond to the stresses of surgery. You should be learning from every patient you anaesthetize.
- Be proactive and take ownership of the case. Using the example of a bowel resection again; you should want to put the arterial line in, want to put a central line in, want to offer an epidural. This is all the fun stuff! If you don't know about the patient and passively let your boss make all the decisions you can't be expected to magically be invited to stick a central line in.
- If you can't think of a topic specifically relating to the patient then consider these other options:
 - Crisis management- what would I do if patient's sats dipped now? What if the patient had an anaphylactic reaction to the antibiotic- how would I manage that? How might they present?
 - Sonoanatomy- scan the patient's neck, identify the IJV and ICA, follow the brachial plexus down. Get the best images you can.
 - Equipment- choose a component and explain how it works, eg. oxygen analyser. If you don't know find out how.
 - If you are a trainee there is always a WBA you can do! Again these need to be planned ahead of time.
- Critically appraise everything you and your supervisor do. Why did you choose that particular muscle relaxant/ volatile/ opioid? Why did something work well or not well? Working with lots of different people allows you to be a magpie of sorts and pick the aspects that work best for you. If you see your boss do something strange or different- challenge them. Ask them why they did that.
- If none of the above appeals then reconsider why you are doing anaesthetics in the first place.

I recommend keeping a logbook of your cases and procedures. Meet with your supervisor regularly. Construct a learning plan and be disciplined to stick to it. The more specific the objectives of your plan are the better. Appendix 3 of the ANZCA Curriculum Booklet is an excellent place to start for your knowledge objectives- this is something you can control unlike procedural targets. The First Year is challenging and intense and is where the foundation of your professional career is laid. It demands a lot of effort.

Tools of the trade



The chair is one of them, too.

Monitoring- all those pretty waveforms

The best and most important monitor is a vigilant anaesthetist. Your brain is better than the most expensive machine in the world- never forget that. Using a machine to 'watch' the patient instead of yourself is a poor substitute. Our brain has the shortest lag phase of any monitoring device and the most powerful microprocessor. We spend an inordinate amount of our professional lives looking at monitors and ensuring they are working correctly to feed us a constant assortment of pretty waveforms. A screen filled with waveforms all demonstrating normal parameters is a very comforting thing to behold. Conversely the loss of a waveform or the peal of an alarm sounding is likely to confer a degree of distress. We need to be very familiar with our monitoring devices and for each of them consider the following questions:

- Why do I want this monitor
- How does the device work
- How do I interpret the information it provides

The College of Anaesthetists like similar organizations around the world mandates which monitors we use. If you are planning on sitting the primary then you will need to understand how all the monitors work. It is not in this book's scope to explain this but I recommend *Ward's Anaesthetic Equipment* and the website howequipmentworks for excellent explanations.

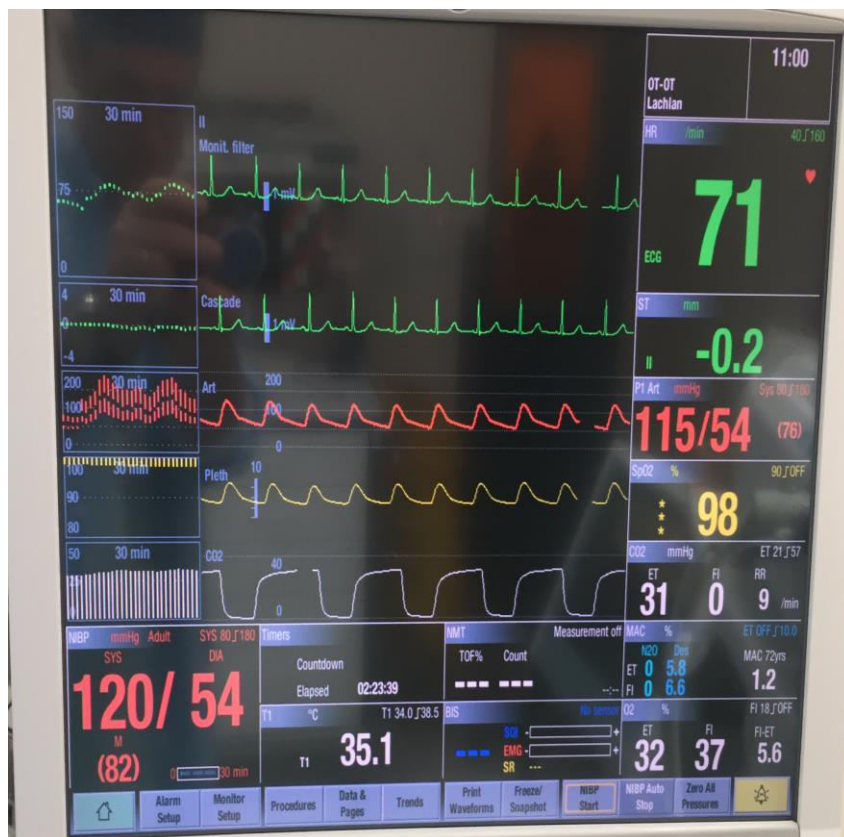

Let's consider a standard anaesthetic workstation monitor. The above screen is from a GE Aespire machine. We'll start at the top of the screen and work our way down.

ECG- the default lead displayed on most monitors if you have the standard three electrodes (white is right, red over the heart and black is opposite to white) on your patient is lead II. This is the same as the rhythm strip on a 12 lead ECG. Why is this the default? Because lead II is the best lead to see p waves and these are the first casualty of the commonest perioperative dysrhythmias, namely nodal rhythms and atrial extrasystoles. Almost every other patient will be transiently in a nodal rhythm at some stage if you look closely enough. Most machines will have the lead displayed over two lines to help analyse rhythm disturbances as per the rhythm strip analogy. The ECG will also give you the heart rate and display ST segment changes. Having a 30 minute trend on the side helps appreciate what's going on with the ST segment better. The ECG is very prone to artefact and electrical interference and it also tends to scrunch up the QRS complex to make it look narrower than what it actually is. If the QRS looks broad on the monitor they have a bundle branch block for sure. Some people like a five lead arrangement in which case the ST segment from several leads is analysed. This might be done for your 'cardiac' patient. I never bother with this though as five leads markedly increases the chances for artefact generation and for them to fall off and get tangled. The ST either changes or it doesn't and you'll pick it up on lead II. Baseline drift artefact is common and is best addressed by shaving the intended site and getting a new electrode.

Pulse Oximeter- The oximeter is the only monitor that we apply to a patient that is mandated must be in use for every patient having a GA. As well as the sats it gives us the heart rate and displays a waveform as well as providing the ubiquitous 'beep' of the anaesthetic machine. The device is validated down to sats of about 75%. Below this you should appreciate that things aren't going very well. Modern oximeters are pretty robust and you should believe your monitor unless you have compelling evidence otherwise. If you have a crappy waveform then the reading is not reliable. When the sats change you should look at the patient, look at the waveform and check the probe in that order.

Capnograph- graphical representation of the expired carbon dioxide concentration. Units most commonly are in mmHg and most machines won't graphically display levels above 60mmHg or so but will tell you the peak value. The respiratory rate is most commonly derived from this waveform. If I was only allowed one monitor then I would choose the capnograph every time. The capnograph is of great utility to the anaesthetist as it gives the following information:

- Tells you if the tube is in the right hole! More on this later.
- Tells you of the integrity of the circuit. The first sign of a disconnection is loss of the capnograph.
- Adequacy of ventilation- carbon dioxide tension is directly proportional to alveolar ventilation.
- Non invasive measure of cardiac output- how much CO₂ is expired depends on how much is delivered from the tissues to the lungs by the cardiac output. While it doesn't give you absolute values it indicates trends which are clinically useful. If you're in the

unfortunate situation where chest compressions are in progress- the capnograph is the best indicator of the adequacy or not of these. Similarly if there has been a sudden drop in cardiac output eg pulmonary embolism then the first thing you will see on your monitors is a drop in expired CO₂.

- Integrity of soda lime- the best indicator of whether this is exhausted is seeing a rise in the inspired CO₂ concentration.
- Abnormal waveform analysis- if expiration is obstructed/ slow/ incomplete this will be demonstrated by loss of a plateau on the capnograph and replacement with an upsloping 'shark's fin' waveform. There are multiple causes of this, a common pathological cause being bronchospasm.

Non-invasive Blood pressure (NIBP) – anaesthetic machines use a DINAMAP to do this which uses the principle of oscillometry. This is very convenient but prone to fault. The most reliable value is the MAP (maximal oscillations) and the least reliable value is the diastolic pressure. You need a correctly sized cuff and appropriate time intervals on the cuff cycle and remember to turn it on. Kinked tubing or a cracked o-ring on the connections are common causes of malfunction as is failing to push the lead into the module firmly. NIBP is also unreliable for patients in AF and is prone to interference by movement artefact, especially surgeons leaning against the cuff. If you're unsure about a BP value you can at least confirm the systolic manually by palpating for loss of the pulse during cuff inflation.

Oxygen- some machines use a fuel cell (oxygen electrode) and some use a paramagnetic analyser. The Aespire machine uses both. The inspired (F_I) and expired (F_E) oxygen concentration is displayed with the difference equating to how much the patient has consumed.

Volatile and N₂O analysis- this is done using infrared analysis from gas taken from the sampling line. As well as measuring the F_I and F_E of each agent the machine will also generate a MAC value. MAC is one of those ubiquitous concepts in anaesthesia that you have to be intimately familiar with. It is discussed in detail in the chapter on volatile agents. The machines will default to MAC values for a 40 year old adult. As age is the most important physiological parameter that alters MAC I think it is useful to take advantage of the machines' capacity to generate an age corrected MAC. To do this you just have to enter the patient's age in the patient demographics section. This has been done on the example screenshot above. Recall that if you giving multiple agents (Nitrous plus a volatile) then their MACs are additive- this is how the monitor will display them but this is not a true representation of the actual clinical state as explained in the chapter about volatile agents.

NMT (Neuromuscular Transmission)- this will be dealt with in more detail in the chapter on muscle relaxants as they are inextricably linked. Suffice to say that you must have this monitor in use if you have administered paralysing agents. A quantitative NMT monitor (eg. Stimpod, GE module) is preferable to a qualitative one (Fisher and Paykel) but unfortunately at present there is no good monitor on the market. The GE device suffers from the acceleromyography component fading and there being poor correlation between what you observe and feel versus what values are displayed on the monitor, eg. Hand visibly twitching in

response to stimulation and the monitor saying there's no twitches and vice versa. The three modes you will use and need to be familiar with are:

TOFC and TOFR, Train of Four Count/ Ratio; DBS, Double Burst Stimulation and PTC, Post Tetanic Count.

TOFC/R- device delivers 4 supramaximal stimuli at 2 Hz to electrodes usually placed over the ulnar nerve at the wrist. It will count how many twitches result and this is termed the train of four count (TOFC). This is reliably assessed qualitatively. Loss of the fourth twitch equates to 75-80% blockade, loss of the third to 85%, of the second to 90% and the first to 98% blockade. If there are four twitches it will compare the strength of the fourth twitch versus the first and give this as a percentage ratio termed the train of four ratio (TOFR). If your quantitative device is not functioning well which is often the case then in the event of four observed twitches I recommend performing DBS.

DBS- Two sets of three stimuli at 50Hz are given three quarters of a second apart and the strength of the second twitch is compared to the first. It is easier to detect fade manually when comparing just two twitches. If there is detectable fade then there is still significant residual paralysis.

PTC- this is used with deep levels of paralysis, i.e one or no twitches observed with TOFC. A tetanising stimulus is given over four seconds, then a pause and single twitch stimuli are given at 1 hertz. Most devices stop after twenty twitches. The number of detectable twitches is termed the post tetanic count. The PTC is inversely proportional to the degree of paralysis. A PTC of 10 approximately equilibrates to a TOF of one and suggests that your patient is likely to be reversible with neostigmine. A PTC should not be repeated sooner than at least ten minutes as the tetanising stimulus exhausts the supply of vesicles at the NMJ.

BIS/ Entropy Monitoring- see the next chapter *The Electroencephalogram and its Application to Anaesthesia*

Temperature- the infra red devices that the nurses use are too inaccurate to have any merit. Use a proper temperature probe if you want to monitor temperature- oesophageal or bladder if you are lucky enough to find a urinary catheter with an incorporated temperature probe. Be aware that it is almost impossible to 'cook' your patient even with a forced air warming device turned on the maximum setting for the entire case. This is because anaesthesia will make all patients hypothermic unless you are actively warming them. The exception to this rule is the patient who is already febrile or the rare individual suffering MH! Consequently temperature monitoring is rarely warranted unlike active warming which is always warranted.

Arterial line- undoubtedly the most useful non routine monitor in our armamentarium. You should have a low threshold to put one in and you should be able to use a plain IV cannula to do it. They are always available whereas your favourite device may not be. Allen's test is a waste of time. If you can't feel a good pulse, don't stick a line there. You can use the ulna artery if you fail with the radial on one side. The critical step when siting an arterial line is to flatten out your cannula the moment you get flashback. Be aware that flushing the line in an awake patient is painful. Some indications for an arterial line are:

- NIBP is unreliable, eg morbidly obese, arms tucked away.

- Long operation with anticipated significant fluid shifts +/- blood loss- gives you another pretty waveform to help pass the time if nothing else.
- To get an ABG- if you need one, you'll probably need more and ICU will want an a-line anyway...
- Patient has a dodgy heart (cardiomyopathy, valvular heart disease, known IHD, septic shock) and you want to know about hypotension and intervene in a prompt fashion when it occurs, i.e. beat to beat continuous pressure measurement. If you have a sick patient the arterial line is going to be the most useful thing to guide your induction.
- To titrate vasopressor or inotrope therapy.
- To facilitate cardiac output measurement eg. Vigileo, PICCO. Arguably a simpler and more useful implementation of the arterial line to guide fluid therapy is via systolic pressure variation. More words about this below.
- To facilitate frequent blood sampling- rarely the sole purpose.

Central Venous Pressure Monitoring- this is a waste of time, there is poor correlation between central pressures and fluid volume status in well patients let alone sick ones. A central line is inserted to get you access if you can't get it peripherally and to facilitate the delivery of drugs centrally, principally inotropes. A central line is also a reliable source of IV access that will last longer than a peripheral cannula if you look after it.

Transthoracic/ Transoesophageal Echocardiography- in an experienced practitioner's hands this provides high quality useful information that may help guide your anaesthetic. It also does an excellent job of distracting you from managing same anaesthetic so it is preferable that this task is performed by another person.

Urine output via IDC- Again, in terms of monitoring, this is a mostly futile exercise as there is very poor correlation between intraoperative urine output and volume status. No urine output at all is significant and usually indicates a kinked or malpositioned catheter. Preventing your patient waking with a painfully distended bladder is a laudable endeavour, however.

Others- these mostly entail expensive, specialized devices of dubious benefit and they will not be considered in detail. They include:

- Pulmonary artery catheter (PAC)- there is reasonable evidence suggesting you are more likely to harm the patient than help give your anaesthetic with a PAC. This is a monitoring device with a mortality rate, albeit very low.
- Evoked potentials- occasionally used in neurosurgery and operated by a dedicated technician who knows more about it than you do.
- Cerebral Doppler, cerebral oximetry- carotid surgery.

Haemodynamic Monitoring

It is not too hard to differentiate on clinical grounds patients with grossly high or more commonly low cardiac output states. A common clinical scenario is the patient who is hypotensive and you want to determine whether this is due to:

1. Hypovolaemia- in which case giving fluid would be a sensible intervention.

2. Decreased systemic peripheral resistance= vasodilatation- in which case 'tightening' them up with a vasopressor is the logical intervention; or
3. Poor cardiac performance = pump failure- Echocardiography is the best means of assessing this but this is not routinely available and requires a high degree of expertise. Often we know beforehand if this is likely- history of CCF, IHD, preoperative echocardiogram. Inotropes may be indicated in the short term to improve cardiac performance.

Unfortunately static measures of cardiac filling pressures (CVP, PAOP) poorly correlate with fluid status and don't determine whether fluid therapy will improve haemodynamics. The utility of monitoring is only realized if it helps you manage your anaesthetic. In terms of outcomes there is conflicting evidence for the utility of goal directed fluid therapy regimens that incorporate cardiac output monitoring. Most advanced haemodynamic monitoring devices determine the stroke volume variability (SVV) of a mechanically ventilated patient during a respiratory cycle. For patients with a high SVV index, which correlates with a degree of hypovolaemia being present, then a fluid bolus is indicated and then the response to this is determined. The humble arterial line gives useful information about the fluid responsiveness (volume status) and the afterload (vascular resistance) and performs as well as more complex and expensive monitors in this respect. It is useful and important to understand the principles of how the arterial pressure waveform can be interpreted to elucidate this information.

Mechanical ventilation induces cyclic changes in vena cava, pulmonary artery and aortic flow. These changes are analogous to what happens during a Valsalva manoeuvre but are not as marked. During inspiration right ventricular preload is reduced due to decreased caval flow as the raised intrathoracic pressure narrows the pressure gradient for venous return between the cava and the right atrium. Right ventricular afterload is increased due to compression of the pulmonary vasculature. Conversely left ventricular (LV) preload is increased by the compression of the pulmonary vasculature and afterload is reduced. Understanding why LV afterload is reduced is conceptually difficult but it is essentially because the pressure gradient between the LV and the extrathoracic aorta is decreased due to the squeezing effect to reduce thoracic blood volume. There is less pressure required to eject blood into the aorta. So during inspiration LV output increases. However the reduced RV preload is transmitted to the LV over the course of a few seconds and this will be reflected in a decrease in LV output during expiration.

Arterial pulse pressure is directly proportional to stroke volume and inversely proportional to arterial compliance. If compliance is unchanged then respiratory variation in stroke volume will correlate with respiratory variation in pulse pressure. Systolic pressure is also closely correlated but also depends on diastolic pressure. The respiratory changes in systolic blood pressure are termed systolic pressure variation (SPV). The respiratory change in pulse pressure is termed ΔPP and is expressed as a percentage= $100 \times (PP_{max} - PP_{min}) / [(PP_{max} + PP_{min}) / 2]$.

In hypovolaemia the respiratory changes are more marked because the superior vena cava and right atrium are more compressible. This further exacerbates the reduction in venous return. RV afterload is further increased because of an expansion of West zones I and II in the lung

(alveolar pressure greater than pulmonary arterial or venous pressure). Also if the ventricles are relatively under filled, they will be operating on the steep (left sided) part of the Frank-Starling curve and small changes in preload correlate with relatively larger changes in stroke volume.

The crucial point to make is that systolic pressure variation or pulse pressure variation are not great indicators of blood volume status rather they are very good at indicating whether a fluid challenge will improve haemodynamics. This is clinically useful information.

Practical clinical application of systolic and pulse pressure variation

Determining whether a fluid bolus is likely to improve cardiac performance, most commonly reflected by a sustained increase in blood pressure, is done by measuring the degree of SPV or Δ PP.

The threshold values are SPV >10 and Δ PP >15%. Some machines automatically calculate these values (The GE Aespire does). The reliability of these values is highest in a mechanically ventilated patient in sinus rhythm. Grossly elevated values can normally be eyeballed by looking at a regular arterial line trace as a 'swing' can be seen.

If you don't have this luxury, one method of objectively quantifying SPV is to change the sweep speed of the arterial waveform to 12.5mm/s, relabel it as a pulmonary artery trace and then scrolling the cursor over the highest and lowest peaks in turn and subtracting the difference.

If a fluid bolus is indicated administer a small amount 100-200 mls and assess the response to this. Intuitively it makes sense to use a colloid in this situation as crystalloids will not remain in the intravascular compartment for very long at all. As you are managing a dynamic, evolving clinical state it is necessary to continually reassess the patient's haemodynamics. The dominant trend in perioperative fluid therapy in the last decade has been to give less fluid.

SELECTED REFERENCES

Changes in Arterial Pressure during Mechanical Ventilation. F Michard. *Anesthesiology* 2005; 103:419-28.

Ward's Anaesthetic Equipment edited by A Davey and A Diba, 6th edition, 2011.

The Electroencephalogram and Its Application to Anaesthesia

Intuitively it is very appealing to be able to ‘monitor’ the physiologic state that we are trying to produce in our patients’ brains. The electroencephalogram or EEG records the electrical activity of neurons in the outer layers of the cerebral cortex. Anaesthetists have devoted extensive efforts into analysing the effects of anaesthetic agents on the EEG and applying this knowledge into formulating indexes to reflect both the adequacy and depth of anaesthesia. Before I talk about the ubiquitous BIS monitor (Entropy monitor will be briefly discussed) a very brief primer about anaesthesia and the EEG will be provided. This is an area of intense activity and interest in the anaesthesia community and I contend that in the future EEG monitoring in some capacity will become mandatory. The currently available monitors have multiple limitations that preclude them from uniform application and endorsement. The trainee anaesthetist needs to be intimately familiar with these limitations.

Anaesthesia and the EEG

I contend the raw EEG waveform is of far greater utility than the ‘dimensionless number’ produced by processed EEG monitors. To use this waveform optimally requires knowledge in its production, interpretation and application to clinical anaesthesia. The raw EEG waveform is a summation of multiple waves of different frequencies (Hz). These are arbitrarily designated as:

- Gamma >30 Hz -not seen usually as low amplitude and filtered out by skull.
- High Beta 20-30 Hz
- Low Beta 12-20 Hz
- Alpha 8-12 Hz
- Theta 4-8 Hz
- Delta 0-4 Hz

The EEG is produced by postsynaptic potentials from cortical pyramidal neurons. The amplitude of the potentials is low (5-10 microvolts) so they require amplification of the signal and low impedance to prevent artefacts. The EEG has limited specificity and sensitivity as well as poor spatial resolution especially if you are only looking at a few leads as is the case with the currently available monitors like BIS which uses a four lead montage over the fronto-temporal area.

GABAergic drugs like propofol and the volatile agents decrease cortical activity and cause loss of thalamo-cortical connections. These drugs cause very similar EEG changes that can be globally described as a reduction in frequency and an increase in the amplitude of waves as anaesthesia deepens. Slow waves reflect slow oscillations in the activity of cortical neurons. Very slow waves like delta waves are thought to result from an increased degree of asynchrony between the activities of cortical neurons. This is also termed cortical fragmentation. Spindles in the alpha frequency range are frequently seen in slow wave anaesthesia and these are produced as a result of inhibition in the integrity of connections between neurons in the cortex and the thalamus, termed thalamocortical loops. A pathological oscillation results due to negative feedback due to enhanced inhibitory activity in the thalamic reticular nucleus in particular.

EEG changes with anaesthesia:

- Awake with movement- blinks and EMG artefact
- Awake and relaxed- less EMG, high beta activity, 'fuzzy' baseline.
- Awake and eyes closed- may see pronounced alpha rhythm.
- Light planes of anaesthesia- shift to low beta activity, alpha activity.
- Slow wave anaesthesia- *spindle dominant*, slow delta waves with spindle waves of varying Hz's- low beta/ alpha/ theta.
- Slow wave anaesthesia- *delta dominant*, slow delta waves with alpha and theta waves.
- Burst suppression- flat EEG interspersed with 'bursts' of high frequency and magnitude activity.
- Persistent suppression- predominantly flat EEG.

A generic diagram illustrating these changes is presented below as well as a series of traces of a patient at differing concentrations of isoflurane anaesthesia. Some actual traces I have taken of patients are also presented. To truly appreciate the waveform and learn to interpret them you have to inspect them in real life on your monitor on a large number of patients. I highly commend the ICETAP website resource which is devoted to teaching anaesthetists how to interpret the EEG waveform and apply it to clinical practice. Another way to display EEG data is as a spectrogram. The spectrogram represents a strip showing different frequencies (y axis) over time (x axis). Colour (z axis) reflects the power of the amount of a particular Hz. Power is expressed in decibels and is the log of the square of the amplitude of a given Hz component. The spectrogram gives a visual Fourier transformation of the EEG and shows the temporal trend. An example is displayed below for a patient anaesthetized with propofol showing a predominance of slow delta and alpha wave activity- red (high power) bands at the 1 and 11 Hz beginning from about three minutes. The corresponding EEG is displayed for comparison. Below this is a spectrogram for sevoflurane demonstrating the characteristic 'filled in' appearance. Different anaesthetic drugs have characteristic spectrograms which are more distinguishable than their raw EEG traces. The raw EEG traces for propofol and sevoflurane in the two examples appear very similar.

Important facts to note are that slow wave anaesthesia EEG patterns correlate with adequate surgical anaesthesia. These patterns are very similar to those seen in physiological sleep, especially stage three sleep. The appearance of slow spindle waves being superimposed on a slow undulating delta sine wave should greatly comfort the attending anaesthetist. Burst suppression and persistent suppression reflect excessively deep planes of anaesthesia. These EEG patterns are not seen in sleep.

Awake with Eyes Open: Beta and Gamma Oscillations



Paradoxical Excitation: Beta Oscillations



Sedative State: Alpha and Beta Oscillations

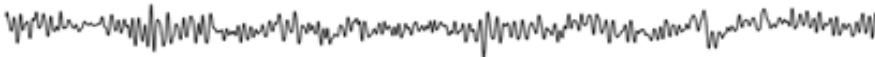

Unconsciousness at Surgical Level: Slow and Alpha Oscillations



Unconsciousness during Induction: Slow Oscillations



Unconsciousness: Burst Suppression

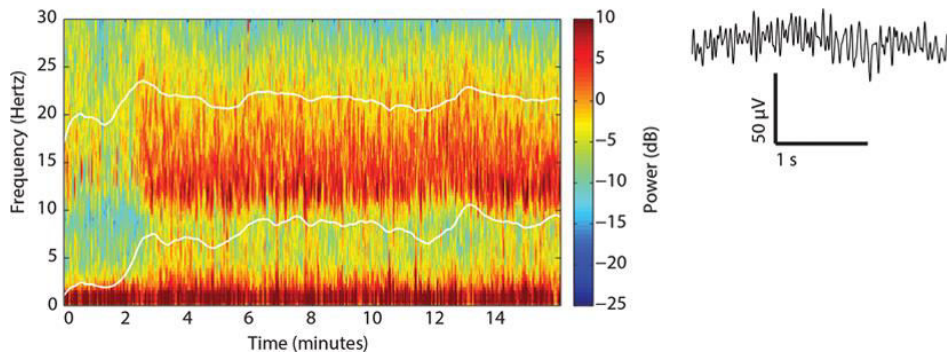

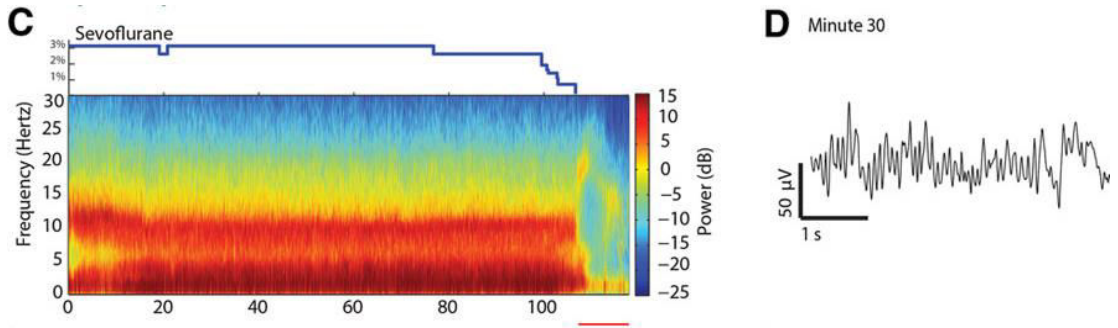

Above three diagrams are reproduced from Figures 2, 5 and 12 from P Purdon et al. Clinical Electroencephalography for the Anesthesiologist: Part 1: Background and Basic Signatures. *Anesthesiology* 2015; 123: 937-60.

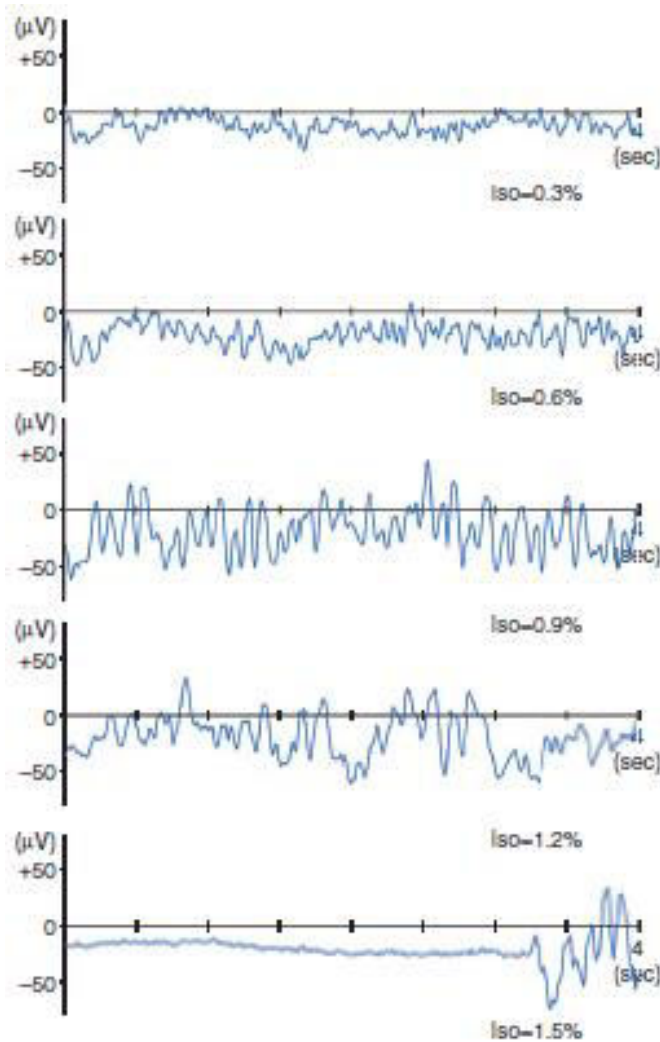
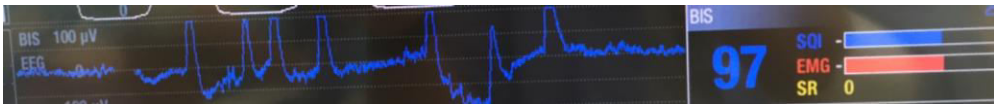

Fig 1 from S Hagihira. Changes in the electroencephalogram during anaesthesia and their physiological basis. *British Journal Of Anaesthesia* 2015; i27-i31.

A series of BIS EEG waveforms recorded from one patient
 The filter is off, sweep speed is the default 25mm/second.



Awake- note high EMG bar, 'fuzzy' baseline due to high frequency waveforms in the high beta range. Large deflections are blinks.



Slow wave anaesthesia- alpha waves and underlying theta wave.

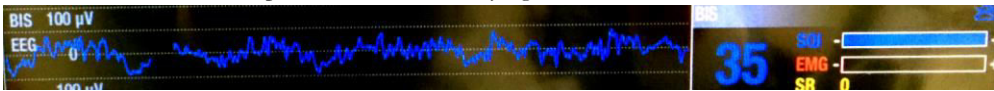

Slow wave anaesthesia- very similar pattern despite different BIS values. Both reflect adequate anaesthesia.

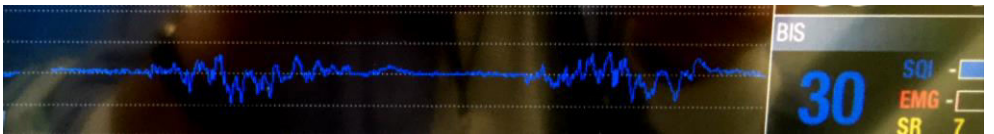

Burst suppression- flat trace interspersed with periods of electrical activity. Appropriately low BIS reading and figures noted on the SR.

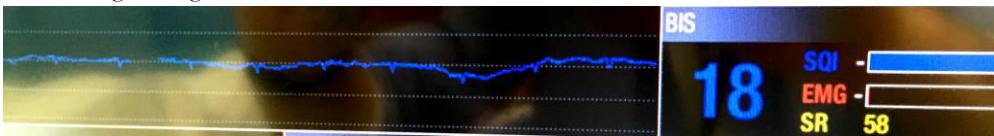

Persistent suppression- very flat trace, high SR, appropriately low BIS. Note superimposed ECG artefact.

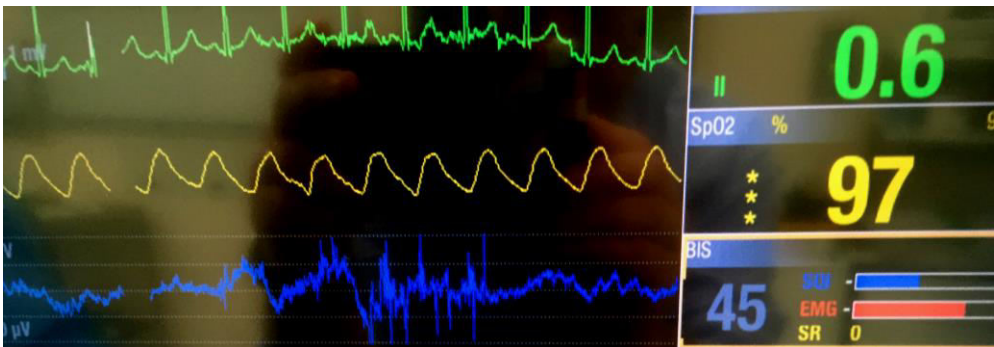

Superimposed diathermy artefact on EEG as well as ECG and consequent high EMG signal on BIS module.

Effect of other anaesthetic drugs on the EEG

Ketamine- induction will increase fast beta activity followed by an increase in theta and delta waves. At high concentrations it will cause burst suppression. When given during propofol/volatile anaesthesia there is an increase in high Hz waves and this will erroneously elevate the BIS reading.

Nitrous Oxide- generally little effect on EEG and consequently BIS. Reduces the amplitude of the EEG, decrease in delta and theta power and increase high Hz power.

Opioids- little effect at low doses, delta dominance with high doses.

Midazolam- will cause similar changes to GABAergic drugs but with a slower onset and offset.

BIS, Bispectral Index- the commonest form of EEG derived 'depth of anaesthesia' monitor used in Australia. Unfortunately BIS fails to fulfil this purpose adequately to justify its routine use. I am not a fan of BIS monitoring and am declaring my bias from the outset. I will attempt to justify my position.

BIS monitoring is only validated for one purpose: for the prevention of awareness in a high risk population as defined in the B-Aware trial. BIS entails applying an EEG electrode (about \$20 worth which is a lot) to the forehead of the patient and through the process of an algorithm that has never been publicly described produces a dimensionless number between 0 and 100. Calculation of the algorithm is very complex and incorporates bispectral analysis, power spectral analysis and time domain analysis of burst suppression. A BIS reading of 0 equates with an isoelectric EEG and 100 with a wide awake subject. Awake patients actually have BIS values in the nineties. Isoelectric does not mean brain dead but a brain dead person will have a very low BIS reading. BIS values between 40 and 60 are thought to equate to an adequate depth of general anaesthesia. A more precise description though would be to say that at these values there is a low likelihood of recall by the patient. This is not the same thing as adequate anaesthesia. Like any other waveform based analysis you need to display the EEG waveform as well as look at the number it generates. Similarly to oximetry; a crappy (artefact ridden) waveform correlates with unreliable readings. The BIS monitor has a SQI (signal quality index) incorporated which indicates the proportion of EEG data used in the index calculation. It also displays the SR, suppression ratio, which is the percentage over the past 63s that the EEG has been suppressed.

You should be able to interpret the EEG waveform as well as you can an ECG waveform: you should be able to tell an 'awake' EEG from an 'asleep' one (see challenge questions). You should also be able to recognize artefact. An example of ECG artefact is presented above.

There are a host of problems implicit with the current prevalent use of BIS monitoring:

- Using it for purposes other than what it was validated for, eg. as a depth of anaesthesia monitor or an adequacy of anaesthesia monitor. I suggest BIS is better for telling if a patient is awake than asleep! That is why it is a reasonably reliable 'awareness monitor'. It is not useful as a tool to titrate anaesthesia, especially for patients with complex pathophysiology. More about this below.

- It is not validated in children, particularly young children. There are neurobiological reasons why this is the case. Young children have different EEG patterns and responses to anaesthesia.
- Similarly to a pulse oximeter, BIS has a lag period but it is substantially longer than that of an oximeter- of the order of one to four minutes. A video clip of a BIS monitor cable being cut and still displaying values for a further 45 seconds is testament to the delay incurred by processing the signal. This is long enough to imprint events that may be explicitly recalled.
- BIS is fallible and prone to artefact. You can be aware with a low BIS reading and vice versa. The EEG signal is subject to interference by a host of electrical signals the most prominent and important of these being the EMG, or muscle activity in the frontalis muscle underlying the electrode. A Cairns group of anaesthetists spectacularly and definitively demonstrated in a recent study published in the BJA that muscle relaxants *alone* will reduce the BIS reading to values similar to those of a general anaesthetic. The oft quoted indication for BIS monitoring- TIVA with relaxant anaesthetic- is fundamentally flawed when this study is appreciated. The BIS reading does not reflect the true physiologic state in this instance. However, looking at the waveform should alert you to the 'truth'. Below are two figures taken from the Cairns study. The first demonstrates the substantial fall in BIS readings when rocuronium alone was administered to a subject (it was an anaesthetist actually) and its return to awake values when the rocuronium was antagonized by sugammadex. The next figure shows the raw EEG waveform for the same subject given suxamethonium. Although the BIS reading fell, the raw EEG is consistent with an awake subject which is the actual physiologic state. You should be pretty impressed right now.

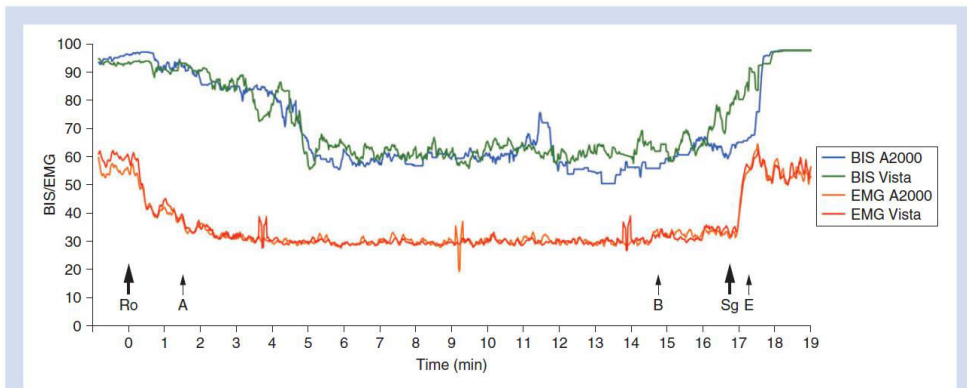
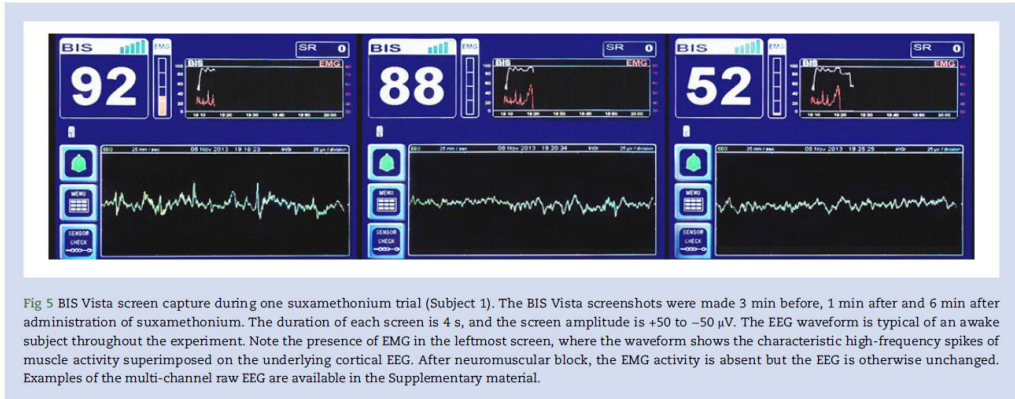

Fig 4 Bispectral index (BIS) and EMG response to rocuronium in Subject 1. Clinical paralysis was evident 90 s after administration of rocuronium (arrow A), and the two BIS monitors show close agreement for most of the experiment. At 14 min 30 s, there was a small rise in EMG and the subject reported that they were able to move their tongue slightly (arrow B). Partial diaphragm function returned at 16 min 10 s, and sugammadex was administered 30 s later. Abbreviations: Ro, rocuronium; Sg, sugammadex. Eye opening is indicated by arrow E.



Both diagrams from P Schuller et al. Response of the bispectral index to neuromuscular block in awake volunteers. *British Journal of Anaesthesia* 2015; 115(Supp 1): i95-103. Used with permission.

- The utility of BIS for its validated indication has been subjected to further study and found wanting especially if you are giving a volatile anaesthetic. Two large trials have failed to demonstrate the superiority of BIS monitoring over end-tidal volatile alarms for the prevention of awareness. This should not surprise us; most cases of awareness are due to anaesthetist error or equipment fault or deliberate under dosing because of clinical concern with the risk of cardiovascular depression, eg trauma patient. An analysis of the raw data from the B-Unaware trial was particularly revelatory: over three million pairs of data points collected during the maintenance phase of anaesthesia were analysed. The diagram below shows how ET volatile concentration correlated with the BIS reading. You can pretty much rule a straight line through the median values. *This should astound you!* This study demonstrates how BIS cannot be used to titrate to a 'depth of anaesthesia' because a dose-response relationship between the dose of anaesthetic and the depth of anaesthesia (as represented by the surrogate measure of a BIS value) is not apparent. When the patient is anaesthetized the BIS tends to sit between thirty and forty regardless of changes to anaesthetic concentration during the maintenance phase.

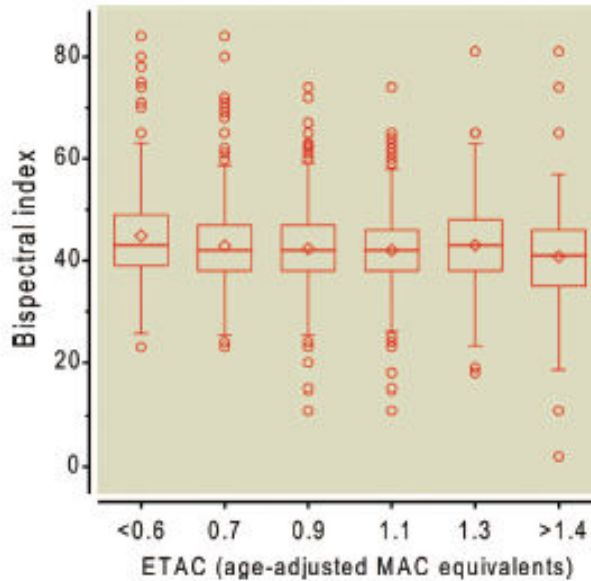

Fig. 4. Box and whisker plots of bispectral index ranges at six age-adjusted minimum alveolar concentration (MAC) ranges: <0.6, 0.6–0.79, 0.8–0.99, 1.0–1.19, 1.2–1.39, and ≥ 1.4 . For each range, median bispectral index values were calculated for each patient using the pharmacokinetically stable end tidal anesthetic concentration (ETAC) data. The box and whisker plots were then constructed from these median values. The boxes depict the median values and the 25th and the 75th percentiles. The whiskers represent the two-fifth and ninety-seven-fifth percentiles.

From E Whitlock et al. Relationship between bispectral index values and volatile anesthetic concentrations during the maintenance phase of anesthesia in the B-Unaware trial. *Anesthesiology* 2011; 115: 1209-18.

Entropy

This is another processed EEG monitor developed by GE. It looks at the degree of lack of synchrony, frequency domain and burst suppression analysis. It displays two dimensionless values on the same range as BIS.

Response entropy- incorporates EMG signal, 0.8-47 Hz, is thought to reflect short term changes better.

State entropy- 0-32 Hz, EEG only.

It shares all the limitations of BIS.

Clinical Use of the BIS Monitor

If you insist on using BIS then put the electrode on the patient before they're 'asleep', display the EEG waveform and don't switch your brain off. Turn the filter off on the settings because otherwise it will remove the slow delta waves which you want to see. The only validated indication is to prevent awareness in a high risk adult population undergoing propofol-based anaesthesia. Be aware of the confounding effects of muscle relaxants and non GABAergic drugs like Ketamine, Nitrous Oxide and Dexmedetomidine on the BIS reading. If the BIS value changes you should inspect the EEG waveform and determine whether it is concordant or

discordant in the context of the anaesthetic at that particular time. A low SQI and high EMG index should make you suspicious of the integrity of the value. The worst thing you can do is 'run' your anaesthetic to a BIS value. At best BIS may complement your anaesthetic dosing but anaesthetists predominantly use their experience to determine dosing, not by deferring to a dimensionless number. We have abundant experience correlating MAC values or propofol plasma concentrations with the desired pharmacodynamic effect. BIS does not enhance this, merely confirms it. I contend BIS monitoring hasn't made us better anaesthetists.

Titrating anaesthesia with BIS

This can be done by focussing on the EEG waveform and mostly ignoring the BIS value! A slow wave anaesthesia EEG pattern is consistent with adequate anaesthesia. If this pattern is lost when the patient is subjected to nociceptive input (i.e. surgical stimulation) then the depth of anaesthesia is inadequate. Nociceptive input tends to depolarize the thalamo-cortical system. The EEG changes are loss of spindles and delta waves and the presence of high frequency waves. The presence of burst suppression or the presence of numbers on the SR of the BIS module correlates with excessively deep anaesthesia.

SELECTED REFERENCES

Bispectral index monitoring to prevent awareness during anaesthesia: the B-Aware randomised controlled trial. P Myles et al. *Lancet* 2004; 363: 1757-63.

Anesthesia Awareness and the Bispectral Index, M Avidan et al. *New England Journal of Medicine* 2008; 358: 1097-108.

Prevention of intraoperative awareness in a high risk surgical population, M Avidan et al. *New England Journal of Medicine* 2011; 365: 591-600.

Relationship between bispectral index values and volatile anesthetic concentrations during the maintenance phase of anesthesia in the B-Unaware trial. E Whitlock et al. *Anesthesiology* 2011; 115: 1209-18.

Practical use of the raw electroencephalogram waveform during general anesthesia: the art and science. C Bennett et al. *Anesthesia and Analgesia* 2009; 109: 539-50.

Response of the bispectral index to neuromuscular block in awake volunteers. P Schuller et al. *British Journal of Anaesthesia* 2015; 115(Supp 1): i95-103.

icetap.org and anaesthesiaeg.com are both excellent websites designed to teach Anaesthetists to use and interpret the EEG waveform optimally.

CHALLENGE QUESTIONS

1. What is the blue strip on the back of the ECG dot for?



2. One of these EEG waveform recordings is from an awake patient and the other is from the same patient when they are anaesthetized. Which is which?

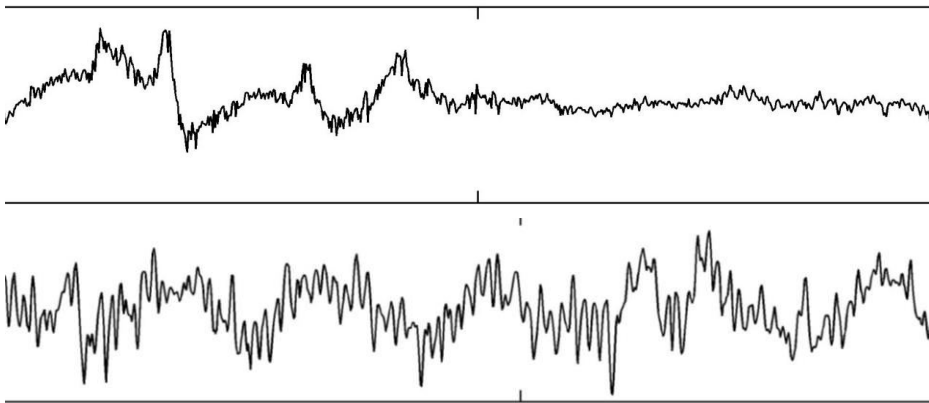

3. How do we know if our patient is 'asleep'?
4. How does a pulse oximeter isolate the pulsatile signal? How does it account for ambient light?
5. Is it okay to use 5% dextrose to pressurize an arterial line?
6. What's this thing?



7. How many anaesthetists does it take to change a light bulb?

ANSWERS

1. The blue strip is like a piece of sandpaper. It is intended for use as an abrasive on the patient's skin to improve contact with the ECG electrode.
2. Top one is awake, bottom one is anaesthetized. More examples below.

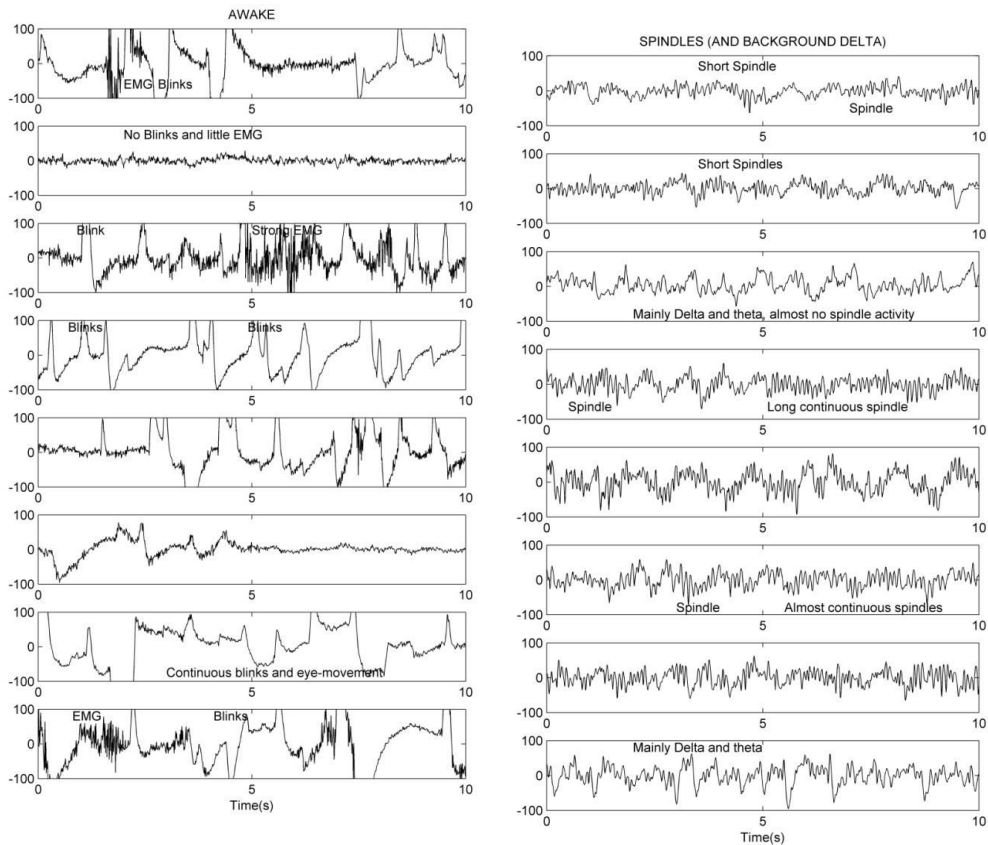

3. The short answer is we don't know for sure. If our criterion is lack of awareness or complaint by the patient that they were awake then we can confidently assert that we get it right in the vast majority of cases. The complexities of understanding and testing consciousness limit discussion beyond this criterion. It is an utterly fascinating aspect of anaesthesia nonetheless.
4. Pulse oximetry is a spectrophotometric form of oxygen analysis. Every anaesthetist should be able to explain how they work which entails spitting out the Beer-Lambert law for the absorbance of light. Remembering beer is brown and Lambert starts with an 'L' helps work out which bit accounts for the concentration of the medium and which bit refers to the length that light has to travel. We are only interested in the arterial oxygen saturation which accounts for only about two percent of the total absorbance signal. To remove the non-pulsatile or 'background' signal the device measures the absorbance hundreds of times a

second and isolates the changing (AC) signal from the non-changing (DC) one. It then calculates a normalization ratio of the absorbance of red and infrared light and compares this to an algorithm derived from humans. The formula of the ratio is $(AC_{660}/DC_{660})/(AC_{940}/DC_{940})$. The LEDs cycle in a particular order to account for background light. The red one goes on first then the infrared one and lastly both are off. The device subtracts the absorbance of the latter to account for ambient light. It is remarkable that you can now buy an oximeter for ten dollars from Hong Kong (I don't know how reliable they are).

5. Absolutely not! This is potentially lethal. Arterial lines are used for sampling so if dextrose is pressurizing the line it will contaminate blood specimens and give a falsely high BSL.
6. This is an equipotential earth. They minimize current flow between leakage protected devices. I have never seen one used although every operating theatre has them dotted around the place.
7. One, but the bulb has to be cardiac-protected. (Apologies proffered.)

The Anaesthetic Machine

The machine that goes beep is our defining piece of equipment and we are obliged to be very familiar with its workings. You should know how to check your machine and be proficient in performing a level 2 check. You should be able to troubleshoot the vast majority of machine problems without having to rely on your anaesthetic assistant. I highly recommend when you are on night duty to follow the night anaesthetic tech/nurse around as they check the machines in the theatre complex. Watch them do a few machines then get them to watch you do some. The next night get them to watch you check all the machines. By the following night it will be second nature.

Anaesthetic machines are increasingly expensive and complex pieces of kit but they all share the same components: ventilator, means of administering gas mixtures and volatile agents, breathing circuit and monitoring modules.

You must be able to answer the following questions about your machine:

- How do I know if it has been checked?
- What components work in the event of a total loss of power- can I give a volatile anaesthetic?
- How do you change the soda lime, fill and change the vaporizers, set up for a new patient?
- How do I attach, set up and check a new circuit.
- How do I turn the suction on? Where's the O₂ flush button? How do I activate the ACGO?
- What are the commonest problems with this particular machine and how do I fix them? (Leaks are the commonest problem with every machine.)
- How do I configure ventilator settings and switch between modes during a case.
- How do I start and finish a case. Where is the timer? (Hitting the alarm silence button on all GE machines will give you a 2 minute timer by default- holding the same button for 4 seconds will make it a 5 minute timer. Hardly anyone seems to know this!)

You should be comforted by the knowledge that your machine has a lot of safety features built into its design and that failure of the machine is a very rare event.

Power failure- most machines have battery backup and most won't miss a beat if you inadvertently pull out the power plug. Machine failures still occur and power board failure is the commonest cause I have seen. Like motor vehicles they are not built to last and electrical glitches are increasingly common as they age. In the event of an intraoperative power or major electronic failure be heartened by the knowledge that you can manage quite comfortably while your tech secures an alternative machine. Yes your ventilator will not work and you will lose monitoring. But the latter can quickly be partially restored with a portable monitor- your transport monitor in recovery is a good choice as it will have capnography. You can still manually ventilate and deliver a volatile anaesthetic- the exception being Desflurane as it requires power to function. Manual rotameters will still function and most modern machines with electronic rotameters have a back-up manual oxygen control eg. GE Avance machine. The self-inflating bag on the side is a poor substitute for your circuit and is very rarely ever required- though it is mandatory that it is present with your machine.

To reinforce some of the above points and answer some of the questions posed above I will discuss the Aespire machine as an example and describe how to do a Level 2 check on this machine and highlight some aspects consistently done or understood poorly by trainees.

AESPIRE VIEW ANAESTHETIC MACHINE Preoperative Tests

CHECK SERVICE DATE, TURN THE SUCTION AND SCAVENGING ON & check functioning.

Suction is vitally important- if it fails when you need it the consequences can be dire. There should be just one point of activation for your suction and everyone must know where that is. Suction commonly fails because of a leak around the canister or the hose has come apart from the elbow connection. This problem is easily rectified but only if you realize there is a problem in the first place. Scavenging provides the background hissing sound ubiquitous to operating theatres.

LOW-PRESSURE LEAK TEST – to be performed with the machine off.

- Attach the leak test device to the auxiliary gas outlet and divert gas flow from circle to the ACGO by turning the switch down.
- Open all flow controls by turning them anti-clockwise.
- Squeeze the bulb until it is collapsed, leak if it inflates within 30secs.
- Turn vaporizer to 1%. The bulb may expand. Squeeze the bulb until it collapses and monitor for leaks. Repeat this test for each vaporizer attached to the machine.
- Once the low-pressure test is complete ensure that the vaporizers are turned off, disconnect the test device from the auxiliary gas outlet and turn the ACGO switch back to circle or up to its original position. Close flow controls.

This component is checking the 'back-bar' and the vaporizers connected to it. If the bulb inflates it must be drawing gas from somewhere proximal to the alternate common gas outlet, i.e. there is a leak. A vaporizer that is poorly seated is the commonest problem. You should be able to remove, fill and replace vaporizers. Vaporizers are designed only for a single specific agent and have agent specific devices to prevent them being filled with any other agent than the one they are designed for. The safe-t-lock system prevents two vaporizers from being turned on simultaneously. The Desflurane vaporizer must be plugged in and takes a short time to warm up before it is operable. It is the only vaporizer than can be filled when it is in operation.

CYLINDER LEAK TEST- to be performed with the machine off.

- Disconnect the wall supply of oxygen
- Turn O₂ cylinder on & note pressure
- Turn cylinder off & monitor pressure for 1 minute, leak if pressure drops >690kPa
- Reconnect wall supply of oxygen

The sleeve index system prevents gas hoses being connected to the wrong outlet and they are also colour coded. The oxygen cylinder contains gas under very high pressure- about 150 atmospheres in a full cylinder. The pressure reading directly correlates with how much is left in the cylinder- this is not the case with a nitrous oxide cylinder which contains a mixture of liquid and gas.

ENSURE CO₂ SAMPLING LINE IS CONNECTED & TURN THE MACHINE ON.

CALIBRATION OF FLOW SENSORS & O₂ SENSOR CALIBRATION – 21% O₂

- Release the flow sensor module by pulling open the lever on the insp/exp ports.

- Pull the flow sensor assembly out slowly. Two yellow messages “no insp/exp sensors” will appear on the ventilator screen.
- Unscrew and remove the O₂ sensor from the circuit.
- Press *Menu* key on ventilator screen & select *Setup/Calibration*, then *O₂ Sensor Cal*, & finally *21%*.
- Select *Start cal* on the ventilator screen.
- If calibration passes reinstall O₂ sensor & press menu. (If fail, redo and/or do 100% O₂ calibration)
- Gently reinsert the flow sensor assembly. The two yellow messages should disappear from the screen. The sensors are now also calibrated.

The O₂ sensor is a fuel cell or oxygen electrode and has a lifespan of about a year. The Aespire has two oxygen measurement devices- the electrode and paramagnetic analysis of the sampling line gas. The flow sensors are subject to contamination by water vapour and most machines have a filter placed proximal to them.

GAS SUPPLY, O₂ FAILURE ALARMS, ANTI-HYPOXIC CHECK

- Turn O₂ onto 5 L/min and analyse gas, should read 100% O₂.
- Turn on nitrous oxide onto 5L/min and analyse gases, should read 50% N₂O & 50% O₂
- Reduce O₂ flow and ensure N₂O drops also. Return flow to 5L/min.
- Now turn air onto 5L/min.
- Initiate an oxygen failure by disconnecting the wall supply of oxygen. Observe the gas flows within the rotameters. As the oxygen begins to fall the nitrous oxide should cut off (antihypoxic device) & alarm should sound (O₂ disconnect alarm.) Air remains at 5L/min & analyse gas, should be 21% O₂.
- Turn on O₂ cylinder and gases should return, check cylinder pressure gauge above 9000kpa.
- Close O₂ cylinder & reattach the wall supply. Turn off all gas flows.
- Check wall supply is above 345kpa

Machines with manual rotameters have a mechanical device, a chain, connecting the oxygen and nitrous knobs to prevent the delivery of a hypoxic device. You can feel the chain engaging as you turn the oxygen flow up and down. You must remember to close the oxygen cylinder otherwise it may empty itself as it is regulated to enter the machine at just below the pipeline pressure.

AESPIRE BREATHING SYSTEM (ABS) AND VENTILATOR CHECK.

- Attach re-breathing bag to the patient end of the breathing system and close the APL valve.
- Press O₂ flush to pressurise system to approx 30cm H₂O. Ensure all rotameters are turned off (O₂ basal flow 100ml/min will still be flowing).
- Watch the pressure gauge on the block and the screen on the ventilator for any drops in pressure. The pressure should hold for at least 10 seconds. If the pressure does drop there is a leak within the system. Check that the breathing system is securely attached and that the soda lime container is correctly positioned.

- Once the pressure has held for 10 seconds, ensure gas flows freely between bags and observe the expiratory and inspiratory valves moving freely. Open the APL valve to reduce the pressure.
- Engage the ventilator by flipping the bag/vent switch to vent.
- Fill the bellows using the O₂ flush button.
- The bellows should rise and fall as it begins ventilation.
- Observe that as the bellows rise it inflates fully against the top of the canister
- Observe the ventilator screen. The ventilator should reach the pre set tidal volume of 500mls and respiration rate of 10 within 10 breaths or 1 minute.
- **Note: acceptable levels for the tidal volume are higher than 450mls and lower than 550mls.**
- Squeeze the bag firmly to initiate a high pressure alarm, do not squeeze greater than 100cmH₂O, otherwise the manifold pressure sensor failure device will activate and the machine will need to be turned off to reset. Allow ventilator to reset tidal volume.
- Disconnect the bag and observe the disconnect alarms. – cannot drive bellows and low Ve (volume expired)
- Once checked disengage the ventilator by flipping the bag/vent switch back to bag.
- Turn the ventilator off by pressing the end case button and confirming with the green com wheel.
- Remove the bag from the patient end of the breathing system and attach the filter and CO₂ sampling line.

It is vital to remember to disconnect the filter and sampling tube from the circuit prior to checking the breathing system. This is because the tubing pulls 150mls/min for sampling and this constitutes a leak! Leaks are common around the soda lime canister and you should be able to remove and replace the soda lime canister. The best sign of exhausted soda lime is a rise in inspired CO₂ as measured by your capnometer. Be aware that the first sign of a circuit disconnection you will see is loss of your capnograph- this will occur prior to other alarms being activated. Most machines have a 30second apnoea alarm and you should be wise to this well before the machine alarms.

Your machine is now ready for use.

Don't forget to check your suction, self inflating bag (air viva/ambu bag), intubating tools and emergency equipment.

You should have two functioning laryngoscopes at a minimum. There must be a means to document that the machine has been checked- a logbook if there is no electronic one. Know where your bougie(s) is kept.

Other Equipment

It is a useful exercise to consider what is the minimum equipment required to safely intubate a patient. This is listed below in no particular order with accompanying notes.

- Laryngoscope- at least two, preferably different sizes (Mac 3 and 4), decent light- contacts firmly applied or batteries replaced if not good. Loose base of the laryngoscope handle is a common cause of poor contact. Disposable laryngoscopes are crap and I don't know of any Department that uses them as first choice.
- Endotracheal Tube (ETT)- appropriate size (we use 7.0 for women and 8.0 for men but doesn't really matter) and checked that cuff and pilot tube are not defective.

- Syringe- to inflate cuff on ETT otherwise have a huge leak and can't ventilate!
- Tie/ 'Trachy tape'- something to secure the tube and stop it falling out when some fool trips over the circuit. A piece of cotton tape that you can knot is my preference. I tie a knot against a knot with the first throw around the tube being pulled tight enough to start to pinch the tube- that is how secure you want your tube to be. Micropore/ sleek/ hypofix are not secure- when exposed to slobber, vomit and surgical prep they all peel off taking your tube security with them.
- Scissors- to cut the tape amongst other things. Be careful not to cut the patient, pilot tube or other things you don't intend.
- Facemask with HME filter + means of applying positive pressure ventilation connected to a supply of oxygen. Pull off the stupid plastic spokes sitting on top of the disposable mask and chuck them in the bin. Google 'Clausen's Harness' to understand why they are there in the first place.
- Suction- turned on and making a satisfying hissing sound, placed underneath the patient's pillow so you don't have to look for it when you need it.
- Decent pillow- otherwise don't have patient in correct position for intubation. Patient's occiput should be ten centimetres above the surface of the bed- this requires a decent pillow- invariably in short supply in public hospitals.
- Drugs- including emergency ones. Usually everyone remembers these. If your patient is sick you will need some vasopressor handy.
- IV access- even if you are doing a gas induction most people would secure this before instrumenting the airway. Check IV is working and drip is running and has anti reflux valve and has a port close to the patient for drug administration. Some or all of these may be absent in environments outside theatre like the ED.
- Basic monitoring applied and functioning including baseline measures preferably- NIBP, SpO₂, maybe ECG.
- Capnography- this merits consideration separate to the other monitoring. Capnography is mandated and vital because in the event that you can't visualize the glottis you are totally reliant on it to confirm intra-tracheal placement of your ETT. Capnography should be available and in use for all intubations you perform as an anaesthetist- whether it is in OT, ED or ICU. The exception may be tubing someone who's arrested in the toilet- even so there are portable CO₂ detection devices available for this scenario. (Most anaesthetists aren't on the crash team so there is really no excuse not to use capnography.)
- NMT (Neuromuscular transmission) monitor- if you are paralysing the patient which is how most intubations are facilitated then you need an objective method to monitor this, i.e. twitchiometer. This is neglected by non-anaesthetists who rarely remove tubes on the same day that they inserted them.
- Stethoscope- this is the one time you need it. You are auscultating to compare air entry to each lung to help exclude an endobronchial intubation and for the presence of abnormal breath sounds.
- Table that tilts, moves up and down and works. Not only must the table be tiltable but you need to know how to operate it. One of the banes of my life are 'powered' beds that have flat batteries and don't move when you want them to. Most junior operators have the bed

too low and are already starting to ruin their backs. You should be able to comfortably rest your arms flat on the patient's pillow.

- Oropharyngeal airway- if your patient is edentulous or fat or bearded then you will struggle to bag them without this.
- Rescue airway device- an appropriately sized laryngeal mask airway (LMA). I recommend your favourite second generation device- a failed, instrumented airway is more likely to be accompanied by regurgitation, vomiting and gaseous distension.
- Bougie and stylet- undoubtedly still the most useful devices in the event of a difficult intubation.
- Means to document what you are about to do. Don't forget to grade the view obtained and comment on any difficulties if there were any. If the patient is being transported elsewhere it is useful to document the ETT size and depth at the lips. Expect the tube to be between 20 and 22cm at the lips.
- Last but certainly not least- a dedicated assistant (who preferably knows what they are doing). This person will be applying cricoid pressure if appropriate and taking instructions from you alone until the intubation is completed.

When you add all this up it is quite a lot of stuff and we mostly take it for granted in the operating theatre that it is all there and working perfectly. The absence or malfunction of any one of the above items can account for a disastrous outcome. This is not infrequently appreciated after experiencing a near miss incident in an environment remote to the theatre complex- "You'll never believe what happened in the endoscopy suite this morning..." As well as having a visual image in your head of what equipment you need, you also need to know where all this stuff lives. Again your anaesthetic assistant is the go to person for this information. Invest ten minutes one day before theatre starts and get them to show you where all the 'stuff' lives.

Emergency and Special Equipment

I won't talk about all the contents here but you should know exactly where in your theatre complex the following are kept:

- Crash cart- know how to use your defibrillator. That's what ALS courses are for and why they are mandatory.
- Difficult Airway trolley
- Videolaryngoscopes- both the device and the blades
- Fiberoptic bronchoscopes- some hospitals keep all the above together and others separately.
- Malignant Hyperthermia Kit- the most important content being dantrolene, of course. Most hospitals have barely enough dantrolene in stock to give the initial dose-e.g for a 100kg patient this is 2.5mg/kg or 250mg. *There is 20mg per vial so you need 13 vials just for the first dose!*
- Anaphylaxis Kit- the most useful content being the correct blood tube to put your tryptase sample in.
- Cell saver- need someone with the training and expertise to use it.

- Ultrasound Machine- basic knobology including the all important 'ON' button, autogain, depth adjustment, turning colour Doppler on and off and accessing preformatted settings eg. Vascular, nerve block.
- Rapid Infusion Cannula and rapid fluid infusion device eg. Level 1.
- Syringe pumps- usually kept on a charging stand when not in use.
- Drug fridge- where the 'S' drugs are: sux and syntocinon (and somatostatin).
- DD cupboards- some DD's like ketamine are kept in only one place in our complex for example.

LIGHT RELIEF



The machine on the left is made of Lego. It required about thirty thousand pieces and was made by an American named Eric Harshbarger for GE in 2011. A closer picture is below.



The White Stuff

AKA Milk of Amnesia, Diprivan, Prop's and Michael Jackson's Nightcap

Propofol is the iconic anaesthetic drug that defines our practice and consequently we should be intimately familiar with every aspect of this drug. It is a relative newcomer to anaesthesia being first marketed in Australia in the late 1980's and the first computer targeted infusion device, the 'Diprifusor', was released here in 1997. Apart from ketamine it is the only drug that can be used as the sole component of a general anaesthetic and unlike ketamine it is a reliably pleasant experience. Topics to be covered in this section are:

- Mechanism of action
- Pharmaceutics
- Pharmacokinetics
- Pharmacodynamics
- Practical use of propofol

Propofol TCI is dealt with in the separate section unambiguously titled '*Everything you should know about Propofol TCP*'.

Mechanism of action

I have included this section as the question "How does this stuff work?" often draws a blank from junior anaesthetists which never fails to disappoint me. Propofol's principal action is to enhance the inhibitory function of GABA at GABA_A receptors in the brain. It does this by decreasing the rate of dissociation of GABA from the receptor. GABA is the main inhibitory neurotransmitter and when it binds it increases transmembrane chloride conductance and hyperpolarizes the postsynaptic neuron. Propofol's anti-emetic action is thought to result from enhanced GABA activity on 5HT₃ receptors in the chemoreceptor trigger zone. Propofol also inhibits the NMDA glutamate receptor.

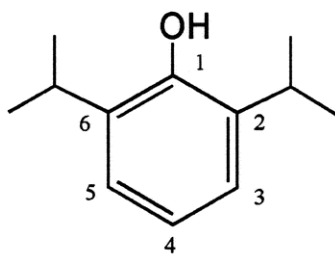

**2,6-Diisopropylphenol
(propofol)**

Pharmaceutics

Chemically propofol is a phenol with two propyl groups stuck on the 2 and 6 carbons of the benzene ring, 2,6-diisopropylphenol. You should be able to draw the structure illustrated above. Propofol is white because it is an emulsion of water and oil- like mayonnaise, only thinner. To be exact the contents of a propofol vial are: water, propofol as a 1% solution

(10mg/ml), soya oil, glycerol (maintains isotonicity), egg lecithin and sodium oleate (emulsifying and stabilizing agents). Some preparations contain sodium hydroxide as a buffer. Absolute contraindications are few- allergy to propofol probably being the sum total. The PI also states that it shouldn't be used in children for purposes of sedation. Practising anaesthetists quite sensibly choose to ignore this explicit advice as this warning relates to propofol infusion syndrome, a rare condition not seen in routine anaesthetic practice. In practice egg and soya bean allergy per se do not seem to be a problem and propofol has been given safely to 'egg allergic' and 'soya allergic' individuals. This is because these individuals are allergic to the protein component and this has been removed from the propofol formulation. The main ingredient of any drug that comes as a liquid is water. Propofol is poorly water soluble but highly lipid soluble hence the emulsion preparation. It is a weak acid with a pKa of 11 meaning it is mostly unionized at physiological pH. There is no preservative in propofol so special care needs to be taken with its use. This means you must draw it up in an aseptic manner and use it shortly after you've drawn it up. After a period of a few hours a syringe of propofol is already colonized with bacteria. Patients have died purely as a result of bacterial contamination of propofol after it was drawn up. If you walk into a theatre and find a syringe of white stuff lying on the trolley- throw it out. Preferably squirt it out of the syringe into a yellow bag. Being oily it is terribly slippery if you spill it on the floor so spills should be attended to immediately. Every drug known to man has been mixed with propofol and it doesn't seem to impair the efficacy of either the propofol or what was added to it. Nevertheless I would advise not adding things to it (lignocaine being an exception) and if you do to label it appropriately.

Pharmacokinetics

Because of its lipid vehicle and being a small molecule, propofol is readily distributed to the vessel rich group and it has a relatively short initial half-life of one to two minutes, often termed the $t_{1/2\alpha}$. Because of the relatively high cerebral perfusion and its rapid blood-brain equilibration time, propofol has a rapid onset of action and if a large enough bolus is given will render the patient unconscious within a circulation time. Again because of its high lipid solubility, propofol has a short duration of action after bolus administration due to redistribution of the drug to other tissue compartments, namely muscle and fat. This accounts for a very large volume of distribution of about 4l/kg. As the blood concentration falls, the concentration gradient initially favouring cerebral deposition of the drug now favours its return back to the circulation. The pharmacokinetics of propofol are best described by a three compartment model. Consider the diagrams below.

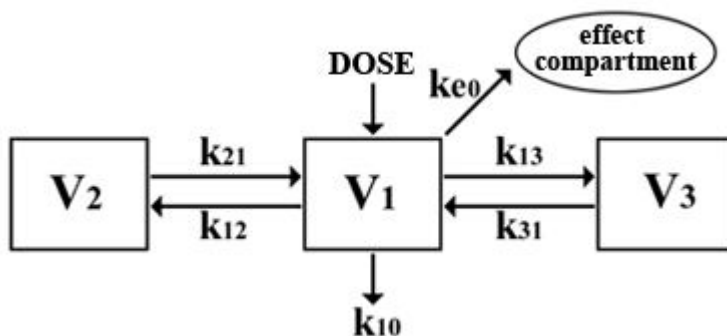

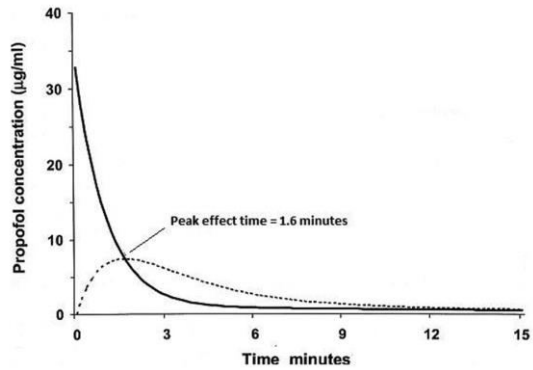
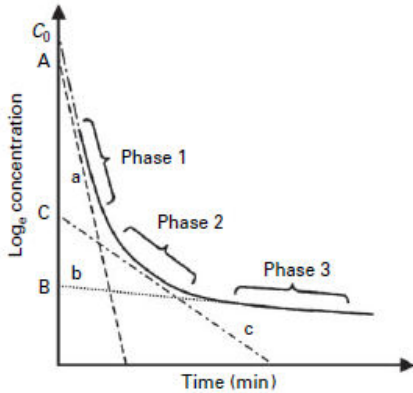

The top diagram illustrates the ubiquitous three compartment model:

V_1 is the intravascular space which the drug is injected into. It is also termed the central compartment. From here it is redistributed to fast (V_2) and slow (V_3) compartments. It is also eliminated from the central compartment. The rate of transfer between these compartments is dependent on the concentration gradients and is a first order process, i.e. it is exponential. A constant fraction is transferred; the process is not affected by the amount of substance. Rate constants, k_{xy} , describe this rate of transfer and refer to the fraction of drug per unit time that is transferred from one compartment to another. For example, k_{10} , is the elimination rate constant for the removal of propofol from the plasma compartment.

V_2 , the rapidly equilibrating compartment or vessel rich group is conceptually thought to resemble well perfused tissues like muscle.

V_3 , the slowly equilibrating compartment is conceptually thought to represent poorly perfused tissues, notably fat.

The next diagram represents the tri-exponential fall in plasma concentration of a bolus dose of propofol over time. Each phase correlates with redistribution to the three compartments described above. The terminal fall in concentration reflects redistribution to the large fat compartment as well as elimination of the drug. The concentration can be described by this unpalatable formula:

$$C_t = A \cdot e^{-\alpha t} + B \cdot e^{-\beta t} + C \cdot e^{-\gamma t}$$

Where C_t is the concentration at time t , A is the y intercept of line a , α is the slope of line a (reflecting distribution from V_1 to V_2), B is the y intercept of line b , β is the slope of line b (reflecting elimination from V_1), C is the y intercept of line c and γ is the slope of line c (reflecting distribution from V_1 to V_3).

The last diagram incorporates the observed pharmacodynamic effect into the pharmacokinetic model. It shows two superimposed curves- the exponentially decaying plasma concentration and the predicted effect site concentration. The effect site of propofol is the brain and this is considered the effect compartment, C_e . A rate constant, k_{e0} , describes the rate of elimination of propofol from the brain. (On the diagram depicting the PK model above k_{e0} is incorrectly indicated as being the rate constant from V_1 to the effect site which should be correctly labelled as k_{1e} .) The amount of drug transferred to and from the effect site is considered negligible in terms of the model. Modelling the effect site enables linking the observed effect with the

concentration of the drug. Note the effect site curve demonstrates hysteresis as there is a delay in the rise of the curve to account for the time it takes for propofol to diffuse into the brain. Similarly the fall in effect site concentration is delayed to account for the reversal in concentration gradients and diffusion of the drug out of the brain tissue into plasma. This is further explored in *Everything you should know about Propofol TCI*.

Propofol is 98% protein bound and undergoes extensive hepatic metabolism to inactive conjugated metabolites (glucuronides and sulphates) which are water soluble and excreted in the urine. Propofol has a high clearance rate of the order of 30mls/kg/minute which since this exceeds hepatic blood flow is thought to be accounted for by extra-hepatic metabolism in the kidneys and to a minor extent in the lungs. Hepatic and renal failure doesn't appear to greatly alter the pharmacokinetic profile of propofol.

The induction dose of propofol for a healthy adult patient is around 2mg/kg. I suggest that the most precise quantification of an induction dose is *that which puts the patient to sleep*. We are titrating the drug to a clinical effect, namely loss of response to verbal and tactile stimulus. There is considerable inter-individual variability in the induction dose. That is why we titrate it to response! To be fair, in a healthy adult it doesn't really matter if it takes one, two or three hundred milligrams of propofol to render your patient insensate to the insertion of a hunk of plastic down the throat.

I will consider three clinically important variations to this scenario: the elderly patient, the paediatric patient and the shocked patient. Elderly patients have a decreased induction dose of approximately 1mg/kg because they have a smaller intravascular volume, reduced cardiac output and an increased sensitivity to propofol. An eighty year old has about a 50% increased sensitivity to propofol compared to a forty year old. Paediatric patients have an increased induction dose of about 3-4mg/kg because they have a relatively larger intravascular volume (V_1) and an increased cardiac output. Shocked (hypovolaemic) patients have a markedly reduced induction dose of about 20% of normal. This is because they have a contracted intravascular volume (V_1) and a greater proportion of the cardiac output is directed to the brain. This functions as a 'blood-brain' circuit. Their cardiac output is reduced and significantly they also have an increased sensitivity to propofol. The diagram below is taken from a swine study demonstrating the 50% increased sensitivity to propofol (as determined by the surrogate measurement of BIS values) in shocked animals. Correcting the volume deficit by fluid resuscitation may address the pharmacokinetic aberration but it does not normalize the pharmacodynamic sensitivity of the shocked patient.

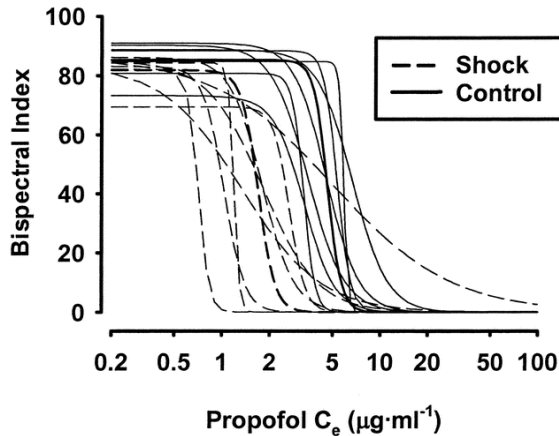

From K Johnson et al. The influence of hemorrhagic shock on propofol: a pharmacokinetic and pharmacodynamic analysis. *Anesthesiology* 2003; 99: 409-20.

The above discussion mostly relates to consideration of a bolus dose of propofol. Commonly we give propofol as an infusion for sedation or TIVA. It is useful to consider one more pharmacokinetic concept in this instance, the context sensitive half-time, CSHT. It is defined as the time taken for the plasma concentration of a drug to fall by half after the cessation of an infusion designed to maintain a steady plasma concentration. The context refers to the duration of the infusion. Another ubiquitous diagram is reproduced below displaying the CSHTs for several anaesthetic drugs.

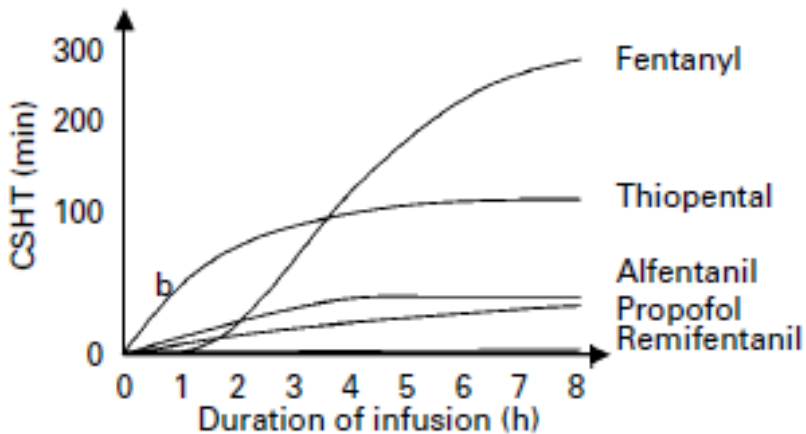

If we just look at the propofol curve we can see it remains fairly steady but does increase with time reflecting saturation of the large fat compartment with propofol. The elimination half-life of propofol is variably quoted as being from 30 to 90 minutes. In terms of clinically useful parameters this is unhelpful. A patient will wake from a bolus dose after a few minutes and from an infusion well before a single elimination half-life has passed. The CSHT is a more useful concept to understand why a patient who has had a long duration infusion will take longer to wake up than a patient who has had a short intravenous anaesthetic. In practical terms decrement times greater than a 50% reduction in plasma concentration are more clinically

relevant with regards to predicting awakening. This is because they will be below the plasma concentration of propofol that correlates with the return of consciousness.

Induction Kinetics

This subject is not described well in any textbook I have yet encountered yet it is essential to understand why we give more white stuff to a child, less to an elderly patient and why we give it slowly to a compromised patient. The three compartment model doesn't account for what happens during induction which is what we as anaesthetists are very interested in. Propofol generally works within a single circulation time. Being highly lipid soluble it readily diffuses out of the cerebral capillaries into the neuronal tissue down a concentration gradient. Although the elderly have reduced clearance for example, altered clearance and redistribution of propofol don't alter the induction dose because the drug *hasn't had time to recirculate*. There are only two factors to consider when formulating an induction dose which is analogous to a loading dose. These are the volume of distribution and the desired plasma concentration (which will equate with the effect site). The actual volume of distribution is not the same as the V_1 in the pharmacokinetic model described above. Consider what happens when you inject a bolus of propofol into a vein on the dorsum of the hand. The bolus will mix with venous blood over the time course of the injection which will dilute the propofol. The injection time is usually quite brief. The bolus travels via the superior vena cava into the right heart and is pumped through the pulmonary circulation. The lung takes up about 30% of the bolus dose on the first pass but does not eliminate it. (Interestingly fentanyl given immediately prior to propofol will reduce the degree of lung uptake of propofol.) The remaining bolus returns to the left side of the heart having been further diluted by the central blood volume residing in the heart, lungs and great vessels. Cerebral blood flow accounts for fifteen percent of the cardiac output, so fifteen percent of the remaining bolus is pumped up the carotid artery to the brain.

Consider how alterations in cardiac output affect this sequence of events.

The effect of cardiac output on the distribution and recirculation of induction agents in the first few minutes are termed the front end kinetics. If cardiac output is reduced there are two major effects. Firstly the circulation time is increased so onset of effect will be delayed and secondly there will be less dilution of the bolus dose by venous blood and a larger peak plasma concentration of propofol will be achieved in the cerebral blood. Peak plasma concentration and cardiac output are inversely related. Conversely if cardiac output is increased the onset time is shortened because the circulation time is quicker and a larger volume of blood dilutes the induction bolus dose and a lower peak plasma concentration is produced. Altered cardiac output changes the plasma concentration produced in the brain and hence alters the induction dose. Lastly consider the situation where there is a relatively large increase in cardiac output, for example the very anxious patient or the septic patient with a hyperdynamic circulation. As well as there being further dilution of the bolus dose there is a further reduction in the concentration of the blood that is delivered to the effect site, namely the brain. This is because cerebral blood flow is autoregulated and so even if cardiac output is doubled, cerebral blood flow remains the same and a decreased proportion of the cardiac output will be directed to the brain. The increased cardiac output of morbidly obese patients contributes to their increased induction dose requirements despite the fact that their V_1 is only slightly larger than that of a non obese subject.

Pharmacodynamics

Sedation- Hypnosis

The principal effect of propofol on the body that we are interested in as anaesthetists is its depression of the CNS. In a dose-dependent but non-linear manner propofol causes a spectrum of CNS depression from subhypnotic effects through varying degrees of sedation through to anaesthesia, coma and ultimately death. Although there is significant variability in individual responses it is useful to have some approximate correlates between desired modes of sedation and plasma concentrations. These values refer to plasma propofol concentrations during the maintenance phase of anaesthesia.

Conscious sedation 0.7-1 mcg/ml (if sole agent and even then only maybe)

Sedation: 1-1.5 mcg/ml

Anaesthesia young healthy adult 4-6 mcg/ml

Anaesthesia older, sicker patient 2.5-3 mcg/ml

Propofol very reliably causes amnesia at subanaesthetic concentrations which is a very fortunate thing.

Note that propofol acts synergistically with other CNS depressants that we commonly give in association, especially benzodiazepines and opioids. This relationship is often graphically represented and a diagram illustrating the synergistic action between propofol and fentanyl is below. The effect site concentrations for a 50% probability of no response to a surgical stimulus are mapped for varying concentrations of each. The curved line on the x-y plane demonstrates synergy. The curve running upward shows the fall in concentration once the infusion is stopped and the bold blue line marks the point of awakening of 50% of the patients.

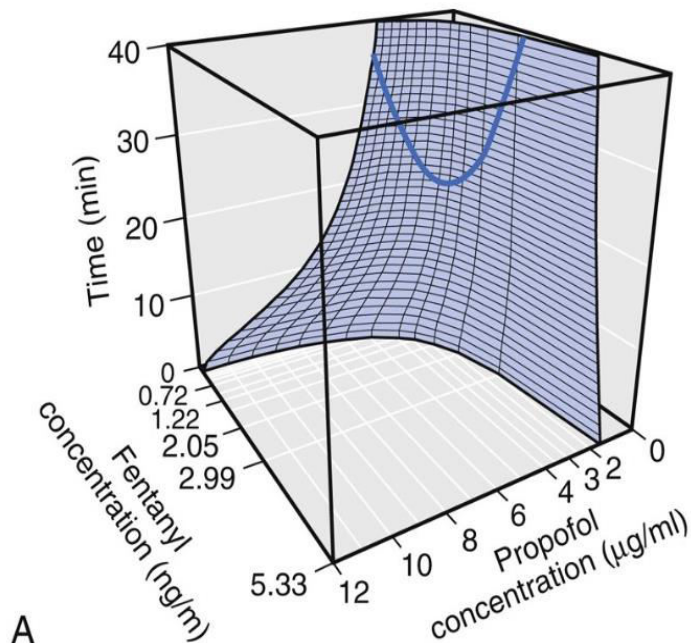

From J Vuyk et al. Propofol anesthesia and rational opioid selection: determination of optimal EC₅₀-EC₉₅ propofol-opioid concentrations that assure adequate anesthesia and a rapid return of consciousness. *Anesthesiology* 1997; 87: 1549-1562.

Note that the Cp_{50} to prevent movement for propofol alone (MAC equivalent) is quite high-12mcg/ml. Opioids will reliably markedly decrease MAC for immobility but have a lesser effect on consciousness and suppression of memory. If a remifentanyl infusion is given in association with propofol then you can reasonably reduce the targets listed above to 2.5 to 3 mcg/ml for a healthy adult and be confident that you are delivering adequate anaesthesia.

Other CNS effects

At subhypnotic concentrations propofol has antiemetic, anti-pruritic and anxiolytic actions. The antiemetic effect is equivalent to one anti-emetic drug. It causes dreams, euphoria and hallucinations and is becoming an increasingly preferred drug of abuse by anaesthetists. It is a potent and reliable anticonvulsant drug but has been implicated in provoking seizures in some individuals typically on emergence. Not uncommonly it causes excitatory phenomena on induction- twitches of the arms and legs that are termed myoclonic jerks. These are not sinister and resolve spontaneously. The development of tolerance does not appear to be an issue for propofol.

Propofol has the following effect on cerebral haemodynamics: it decreases $CMRO_2$, CBF and ICP but has minimal effect on cerebral autoregulation in response to changes in MAP as well as reactivity to $PaCO_2$. In contrast to the systemic circulation it acts as a cerebral vasoconstrictor. It causes burst suppression of the EEG at high doses.

Cardiovascular System

Propofol causes a dose dependent decrease in blood pressure and cardiac output predominantly due to vasodilatation mediated by central sympatholysis. Propofol causes venodilation also hence both preload and afterload are reduced. It is also a directly acting negative inotrope and this effect is more pronounced at high doses. Little change in heart rate is seen as the baroreceptor response is blunted and may see bradycardia especially when given in association with vagolytic drugs like fentanyl. Of note the haemodynamic effect of propofol is delayed after the hypnotic effect. In practice this means they go off to sleep and then their BP crashes a few minutes later. Three minutes should be the default time cycle on your DINAMAP.

Respiratory System

Propofol causes dose-dependent depression of ventilation and most patients will be apnoeic after an induction dose. It reliably and significantly obtunds airway reflexes facilitating the insertion of supraglottic airway devices. Hiccups are not uncommon on induction but spontaneously resolve. Patients breathing spontaneously on propofol have a decreased tidal volume and increased respiratory rate. Propofol impairs the ventilatory response to hypoxia at subhypnotic concentrations and impairs the response to $PaCO_2$ in a dose dependent manner. However it has little effect on bronchomotor tone and doesn't impair hypoxic pulmonary vasoconstriction.

Other Systems

Like all general anaesthetic agents propofol impairs the immune system predominantly by its effects on cell-mediated immune function. It has minimal effect on hepatic, renal and coagulation function.

Practical Use of Propofol

Propofol should be drawn up aseptically just before when you intend to use it. Propofol is safe to use in individuals who have porphyria or are susceptible to malignant hyperthermia. It should be avoided in those with propofol allergy and individuals with mitochondrial disorders. It should be avoided in the first trimester of pregnancy as it has teratogenic effects on rats. I would use it with caution in epileptics (especially those who drive) because of the small risk of precipitating a seizure.

Propofol causes pain on injection. A multitude of interventions to decrease or eliminate propofol pain have been studied. The simplest and most efficacious method is to mix a few mls of 1% lignocaine with an ampoule of propofol. This is quick, safe and easy to do and is my standard practice. Complaints of pain on injection should also prompt the anaesthetist to check that the IV has not tissued!

The time period over which an induction dose is administered is a crucial consideration in the compromised patient. This is because you want to minimize the degree of myocardial depression caused by your induction. Firstly, a slow injection will be diluted with a greater amount of venous blood during the course of the injection and produce a smaller peak concentration as it reaches the heart and subsequently brain. Onset of effect takes longer in the elderly and shocked as they have a reduced cardiac output and hence a slower circulation time. Both these patient groups have increased sensitivity to propofol so your induction must be slow to give time for the drug to get there and to assess its effect. The average induction dose delivered by a TCI pump is less than a manual dose. I think this mostly reflects the fact that pumps deliver it more slowly and allow adequate time for the drug to get to the brain so you can actually titrate it to the patient response. Of course if you give it too slowly you may not achieve the desired plasma concentration. Conversely, if you want to rapidly deepen or obtund your patient nothing works more reliably than a rapid bolus of propofol. Propofol is the drug that will get you in, and out of, trouble.

SELECTED REFERENCES

The influence of hemorrhagic shock on propofol: a pharmacokinetic and pharmacodynamic analysis. K Johnson et al. *Anesthesiology* 2003; 99: 409-20.

LIGHT RELIEF

YOUR EXPLANATION FOR CALCULATING INDUCTION DOSE

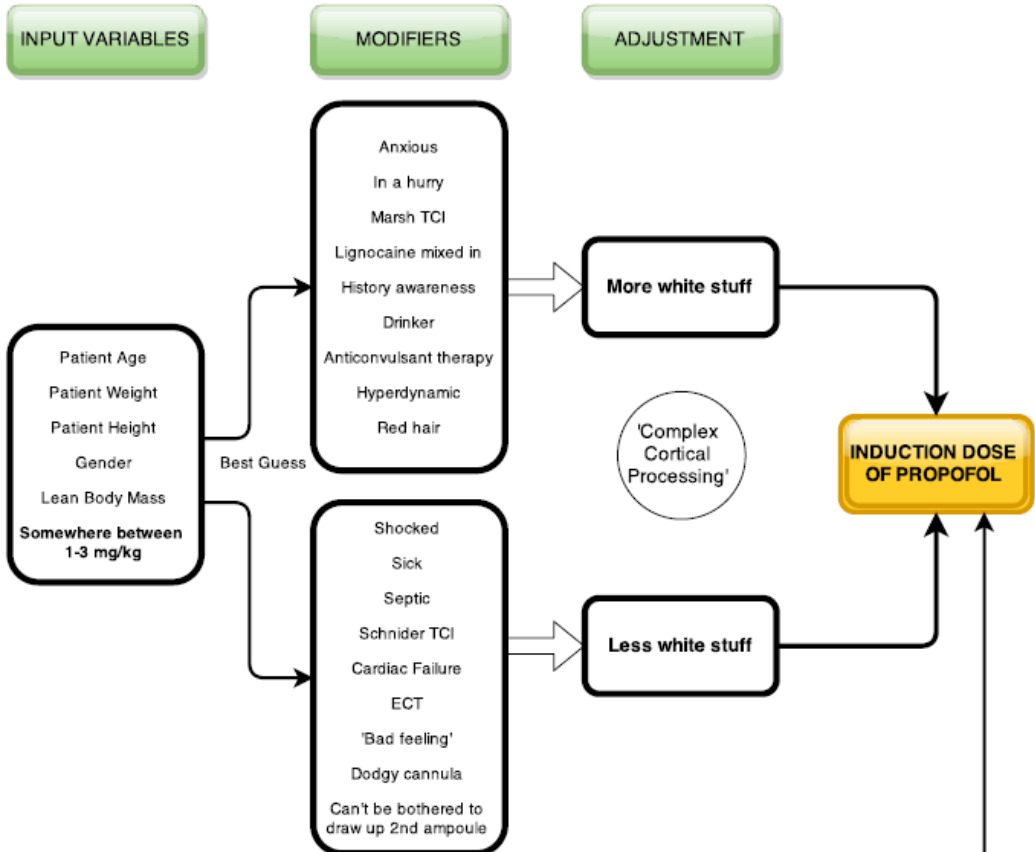

WHAT YOU ACTUALLY DO

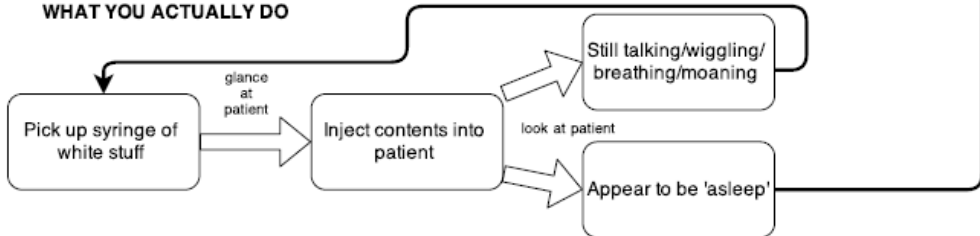

Thiopentone and Ketamine

Ketamine is your friend

These two drugs are used infrequently in anaesthesia especially as induction agents and so they will receive a much briefer 'treatment' than propofol. The focus will be on the differences of these drugs with regards to propofol and the implications for their use in anaesthesia.

Thiopentone

Thiopentone is a barbiturate used most commonly for the induction of anaesthesia. It is a weak acid and comes as a sodium salt hence its common abbreviation, STP. It is reconstituted in 20 mls of water as a 2.5% solution. It is not suitable for use in patients with porphyria. It is the only induction agent listed as Category A in pregnancy. The induction dose is higher, 3-5mg/kg, or about the same as the ubiquitous ampoule for the 'average' adult patient. Like propofol it has a rapid onset of action within a circulation time and has a similar mechanism of action. It has a similar offset of action due to redistribution but because it has much reduced, saturable clearance it will accumulate if given as an infusion and has a much prolonged CSHT compared to propofol. Virtually all of a dose of thiopentone is metabolized by the liver. Severe hepatic impairment is necessary before the kinetics of thiopentone are substantially altered. It can be given rectally but I can't think of any circumstances why I would want to give it that way.

It has similar pharmacodynamics to propofol especially in terms of both causing dose-dependent depression of the cardiovascular, respiratory and central nervous systems. But there are subtle but clinically important differences which are outlined below.

Central Nervous System

Thiopentone is thought to produce a more clearly defined end-point in terms of loss of consciousness and this may be preferable when inducing the compromised patient. It can be used for sedation but there is a narrower therapeutic index between the sedative and anaesthetic concentrations of thiopentone compared to propofol. Patients may take longer to wake from an induction dose. It is a potent anticonvulsant and is still probably the agent of choice to treat raised intracranial pressure and for neuroprotection.

Cardiovascular System

Thiopentone has a lesser effect on the baroreceptor response so a reflex tachycardia will be seen in response to hypotension. Like propofol it is a vasodilator and negative inotrope at high doses.

Respiratory System

Importantly, thiopentone does not obtund airway reflexes to the degree that propofol does. If it is used as the sole agent for induction and then airway instrumentation is performed, this is likely to provoke coughing, laryngospasm as well as bronchospasm. STP can increase bronchomotor tone and should be avoided in those with reactive airways.

Other

Thiopentone does not cause pain on injection but can cause tissue damage if extravasated or injected intra-arterially. Because it is a highly alkaline solution (pH 11) it will precipitate when mixed with acidic solutions like muscle relaxants and local anaesthetics. It doesn't have anti-emetic properties and has a higher incidence of anaphylaxis than any other induction agent. It has no analgesic properties and it is becoming increasingly difficult to secure a reliable supply of this drug.

Ketamine

Ketamine is a phencyclidine derivative and a versatile drug. It is used for the induction and maintenance of anaesthesia and as an analgesic agent for the treatment of acute, chronic and neuropathic pain. It can be given by almost every route you can think of except the inhalational one. It comes as a 10% clear solution in a 2ml ampoule. It interacts with multiple receptors in the CNS (can't be bothered to list them all) but its principal mode of action is by non-competitive inhibition of the NMDA receptor. It is highly lipid soluble, poorly protein bound and has a large volume of distribution but relatively high clearance by hepatic metabolism. It has a weakly active metabolite, norketamine.

Dosing regimens

Intravenous induction anaesthesia- 1-2mg/kg, less if shocked

Intramuscular induction of anaesthesia- 5mg/kg.

'Knock-down' IM dose- 3mg/kg. Basically an ampoule (200mg) will slow them enough to let you slip in a cannula and control the situation.

Premedication PO or Intranasal- 5-7mg/kg. Tastes disgusting (reportedly).

Intraoperative analgesia- initial bolus of 0.3-0.5 mg/kg followed by infusion of similar amount each hour.

Ketamine has unique pharmacodynamics for an induction agent which are considered below.

Central Nervous System

Ketamine is a potent analgesic at subanaesthetic doses. It causes dissociative anaesthesia which is a tricky state to describe. It refers to a catatonic, trance-like state where the patient's eyes remain open with a slow nystagmus like gaze. Although they seem awake, an adequate dose will effectively anaesthetize the patient and ensure amnesia. Patients often have increased skeletal muscle tone and they may have semi-purposeful movements which also can appear unsettling to the inexperienced practitioner. Its effects on the EEG can translate into a transient elevated but erroneous BIS reading although it is an anticonvulsant. Emergence delirium is an adverse neuropsychiatric effect that has effectively curbed its use in contemporary anaesthesia. This is thought to be dose dependent and is reported in 5-30% patients given ketamine. A spectrum of manifestations had been reported ranging from dreams (pleasant and unpleasant), hallucinations both auditory and visual, proprioceptive abnormalities, a sense of detachment and delirium. There is no reliable method to prevent emergence delirium but benzodiazepines are often co-administered in an attempt to do so. I would avoid it in epileptics and patients with addictive personality traits and those with a history of psychiatric illness.

Cardiovascular System

Ketamine is unlike the other induction agents in that an induction dose will increase heart rate and systemic and pulmonary blood pressure for 10-20 minutes. The mechanism is by centrally mediated increased sympathetic drive. Ketamine has a direct negative inotropic effect on the heart that is normally outweighed by its central sympathomimetic action. However a shocked patient who has maximal sympathetic drive may well drop their blood pressure due to this direct effect.

Ketamine has unique effects on cerebral haemodynamics- it increases CMRO₂, CBF and ICP. However, if PaCO₂ is controlled the effect on ICP is minimal. Ketamine is thought to have neuroprotective effects mediated by its action on NMDA receptors.

In an attempt to get the best from both drugs a commonly utilized combination for the induction of sick, compromised patients is 'ketofol'. This is essentially squirting an amp of ketamine into a syringe of propofol and injecting it very slowly. This produces a more familiar end-point in hypnotic terms with less depression of the CVS as well as providing analgesia.

Respiratory System

Ketamine again is unusual in that it does not cause significant depression of ventilation. (A big IV push will probably cause a transient apnoea, though.) Airway reflexes are relatively preserved but this does not equate to their airway being protected despite what the members of the College of Emergency Medicine may think. Salivation and mucociliary production is stimulated by ketamine so co-administration of an antisialagogue like glycopyrrolate is prudent. Ketamine causes bronchodilation (mechanism unclear) and is the induction agent of choice for the patient with active bronchospasm.

Other

Ketamine has minimal effect on uterine tone and is an option for induction of the patient with postpartum haemorrhage. Ketamine is safe to use in MH susceptible individuals. It can induce emesis and elevate blood glucose levels.

In clinical practice this versatile drug is commonly employed in the following scenarios in Australia:

- For difficult pain management
- As the sole agent for short procedures eg. Lancing a boil, dislocation reduction
- Induction of the critically ill or hypovolaemic patient
- For induction of anaesthesia where there is no IV access eg. 'mental dental'.

CHALLENGE QUESTIONS

1. What is the induction dose of Etomidate?
2. What other drugs are white?
3. What sole anaesthetic agent reliably induces anaesthesia, provides analgesia, causes minimal cardiovascular depression and doesn't require a needle to administer it?
4. Can you think of a reason why induction agents have a faster onset of action in children compared to adults other than their increased cardiac output?
5. Patients sometimes report a funny onion like taste when given thiopentone or more commonly cephazolin (they're usually too sleepy to say much with thio although they have been confused with each other on occasion). How do you explain this curious phenomenon?
6. What effect does spinal ketamine have?
7. Is it a reasonable thing to say that having an anaesthetic is like having a sleep?
8. What precautions does the anaesthetist have to take with a latex allergic patient?

ANSWERS

1. The induction dose of anything is enough to put you to 'sleep'. Some Australian readers may be wondering what this Etomidate stuff is. I wish we had it. It is an imidazole derivative general anaesthetic agent that has excellent cardiovascular stability. The induction dose is approximately 0.3 mg/kg.
2. There are a few but they generally don't feature on most anaesthetic trolleys. They are clevidipine, a calcium channel blocker; diazemuls; etomidate lipuro and intralipid. They are all lipid emulsions. The only other thing that could be confused with propofol is milk itself and there are case reports of much badness resulting from inadvertent injection of milk. However, it tends not to come in 20ml ampoules.
3. Xenon. Pity we don't have it.
4. Children are smaller so the drug doesn't have to travel as far to get to the effect site. This is possibly more important than all the other pharmacokinetic factors.
5. If you've managed to accidentally spray this stuff into your mouth when drawing it up you'll realize it does actually taste and smell a bit oniony. The tongue has an excellent blood supply. If you inject thiopentone or cephazolin quickly enough, you will deliver a bolus of drug to the tongue (because minimal mixing will have occurred) which the patient will effectively 'taste'.
6. Pretty much every anaesthetic drug has been injected spinally. When injected intrathecally, ketamine has local anaesthetic and analgesic effects. Most studies have used it as an adjuvant agent. It is not recommended for use intrathecally however as some preparations contain a preservative which is neurotoxic.
7. Not really. Although the average punter equates a general anaesthetic to 'having a sleep', they are not the same thing at all. Sleep is a physiologic state that is not replicated by anaesthesia. Anaesthesia is a drug induced state of unrousable unconsciousness. Sleep has REM and non-REM components which are not seen with anaesthesia. Anaesthesia is not restorative in a physiological sense but some patients feel good when they 'wake up' from it.
8. Generally none. The only things we use that have latex in are some gloves.

Volatile Agents and Nitrous Oxide

If you can smell the smelly, something's wrong

There are only three volatile agents in common use in Australia- isoflurane, sevoflurane and desflurane. Isoflurane is falling out of favour for no good reason so I will focus on the latter two agents. The following aspects of their pharmacology will be considered in detail:

- Pharmacokinetics with a focus on the wash-in curve and its practical implications
- Pharmacodynamics with a focus on MAC and actions on organ systems
- Profile of nitrous oxide and its role in contemporary practice

Pharmacokinetics (in a nutshell)

Volatile agents are so named because they are vapours. A vapour is the gaseous phase of a substance below its critical temperature. The critical temperature is the temperature above which you are unable to liquefy a gas no matter how much pressure is applied. All the volatiles are clear liquids at room temperature. They are ether hydrocarbons with variable amounts of halogen substitution, mostly fluoride. They all smell like petrol fumes essentially with a sickly sweet overtone. You should take a gentle sniff of all these agents so you can appreciate what your patients have to endure during a gas induction. They have boiling points that are substantially above ambient temperatures with the notable exception of desflurane. So a bottle of sevoflurane consists of liquid with vapour above it. The pressure of the vapour inside the bottle is termed the saturated vapour pressure (SVP) and this is temperature dependent but not affected by barometric pressure. When a volatile boils the saturated vapour pressure is equivalent to the ambient or atmospheric pressure.

Some important pharmacokinetic parameters are portrayed below.

Agent	Boiling Point °C	SVP at 20° C	Blood:Gas Coefficient	Fat:Blood Coefficient	MAC %
N ₂ O	-88	gas	0.47	2.3	105
Desflurane	23	669	0.42	27	6
Sevoflurane	58	157	0.69	48	2
Isoflurane	48	240	1.4	45	1.15

One of the necessary evils for the anaesthetic trainee is to develop a detailed understanding of the wash-in curve presented below. All of the agents in use as well as halothane are represented on the diagram. We will consider it in detail. Undoubtedly the premier reference for this topic is the chapter in *Miller* on the uptake and distribution of volatile agents written by Edmond Eger himself- the man who gave us the concept of MAC and is possibly the most cited anaesthetist on the planet. I recommend you read this chapter several times.

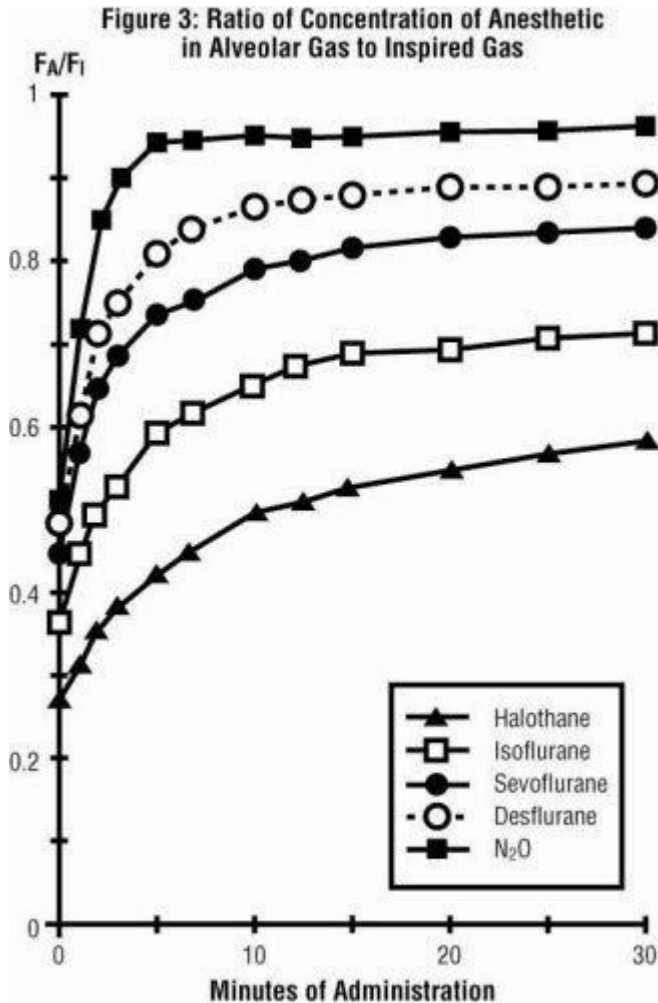

This diagram shows how the ratio of the inspired concentration of the agent, F_I , (whatever you have dialled up on the vaporizer) to that in the lung, F_A , (the expired concentration measured by the agent analyser being our surrogate measure) approaches one over time. Like most natural processes it is an exponential curve. (The simple explanation for the exponential nature is that there is a relatively constant *fraction* of agent taken up on each pass through the lung.) All the curves are initially quite steep due to the unopposed effect of alveolar ventilation conveying agent into the lung where there previously was none. Then all the curves start to diverge as they bend around the 7 to 8 minute mark. This reflects a balancing act between how much agent is being carried away from the lungs into the blood versus how much is being delivered by alveolar ventilation. The critical factor determining at what height the curves bend is the agent's solubility in blood. The parameter that describes their solubility is the blood gas coefficient, usually termed by the Greek letter lambda, λ . The blood gas coefficient is the ratio of the amount of agent in the blood phase and gaseous phase at equilibrium. The partial pressure of the agent in the two phases is the same. So, for nitrous oxide, at equilibrium there is twice as much nitrous oxide in the gas phase (lungs) as in the blood phase (pulmonary capillary

blood). Poorly soluble agents like desflurane and sevoflurane more rapidly equilibrate than more soluble agents like isoflurane and so will more quickly approach a F_A/F_I ratio of one. This is because less of the agent has to dissolve in the blood to reach equilibrium. This all sounds reasonable until you consider the fact that nitrous oxide has a slightly larger blood gas coefficient than desflurane (0.47 vs 0.42) yet approaches equilibrium faster- its wash-in curve is above it. How do we account for this? The answer is the concentration effect. Because nitrous is administered in large amounts (generally F_I of 50-70%) and is taken up into the bloodstream by significant amounts (about a litre in the first minute) this effectively leads to a reduction in the size of the alveoli. The shrinking does two things: it concentrates the remaining nitrous in the alveoli and maintains a concentration gradient to drive uptake as well as draws gas from the conducting airways which contain nitrous into the alveoli. This is termed augmentation of ventilation. If nitrous is given in association with a volatile agent it will also concentrate it in the alveolus and speed up the agent's uptake. This is termed the second gas effect but it has no real clinical value with the poorly soluble agents in use today. This is because they wash-in quickly enough on their own.

Why the bend at the 7 to 10 minute mark? We need to consider the factors affecting uptake of the agent at the level of the alveolus. There are three:

$$\text{Uptake of volatile} \approx Q \cdot \lambda \cdot (P_A - P_V)$$

Uptake is proportional to the product of the pulmonary blood flow (cardiac output), the blood gas coefficient (λ) and the concentration gradient of the agent between mixed venous blood and the alveoli. If any of these factors approaches zero, i.e. get smaller, then uptake also approaches zero and equilibrium is achieved and the wash-in curve will approach one. Generally speaking for an individual agent cardiac output doesn't change much and λ is a constant so the factor that changes and accounts for the timing of the bend is the alteration in the concentration gradient of agent between pulmonary venous blood and the lung. The pulmonary venous concentration is the sum total of the venous return from the various tissue groups in the body. Consider the main body tissue compartments and the blood flow they receive illustrated in the table below.

Body Compartment	%Body Mass	%Cardiac Output
Vessel Rich group	10	75
Muscle Group	50	19
Fat Group	20	6
Vessel Poor Group	20	<1

So, the majority of blood flow goes to the vessel rich group (brain, heart, kidneys, liver) and it takes a few passes (three time constants) through these tissues for the partial pressure of the agent to equilibrate- about seven minutes in fact in the healthy person. This leads to a fall in uptake by well perfused tissues and a rise in the venous partial pressure of the agent. This correlates with a smaller partial pressure gradient between the pulmonary flow and the lung and drives the curve upward. Because the vessel rich group accounts for most of the cardiac output it accounts for the largest bend but uptake of the agent continues to occur in the other tissue groups (otherwise the curve would reach equilibrium). These less well perfused tissue groups

have much longer time constants and theoretically account for further bends in the curve should the timescale of the wash-in curve be considerably extended. There are tissue blood coefficients for each agent for each of these tissues- the fat blood coefficients are listed above in the pharmacokinetics table.

We have mainly considered what happens to the agent subsequent to when it has arrived at the lungs. We will take a step backwards and consider the factors that affect delivery to the lungs. These are the inspired partial pressure (concentration), alveolar ventilation, the fresh gas flow and the functional residual capacity (FRC). In practice we choose a high inspired concentration initially and overpressure the agent to facilitate rapid uptake. If a high (potentially toxic) target is selected you will reach your therapeutic concentration sooner than if you chose a lower but safer target. The higher alveolar ventilation is the more rapidly agent will be delivered to the lungs and the faster the wash-in curve will rise. A higher fresh gas flow will speed up the process of ensuring the gas coming from the machine is saturated with agent. It reduces the time it takes for the inspired concentration to match the concentration dialled on the vaporizer. Lastly the FRC constitutes the effective lung volume into which the agent is delivered. The larger the volume the more dilute the concentration with a consequent slower wash-in as P_A is reduced.

Now we need to integrate a few factors and see how this affects the wash-in curve. Consider the diagram below.

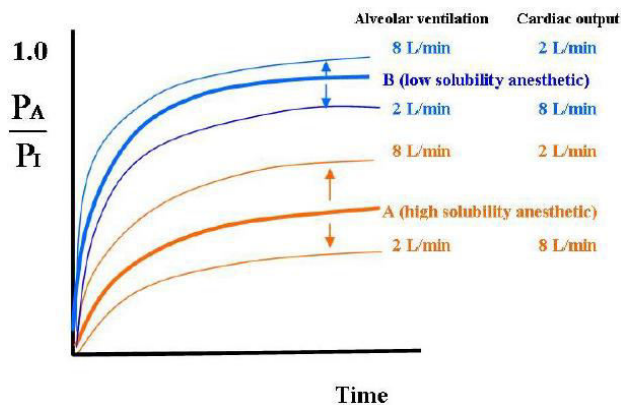

This illustrates that an increase in alveolar ventilation will increase uptake and speed induction. Conversely an increase in cardiac output will slow induction because the increased pulmonary flow effectively helps to maintain a concentration gradient between the alveolus and capillary and equilibrium is not reached. The opposite effect results with a reduction in ventilation or cardiac output. Note that these changes affect a more soluble agent to a greater degree because poorly soluble agents already rapidly equilibrate.

Practical Implications

We use the expired concentration of a volatile agent as the surrogate measure of the concentration in the lung which is considered to have equilibrated with the concentration in the blood which again has equilibrated with that in the brain which is the effect site. On induction

we choose a high inspired concentration and a high fresh gas flow to wash agent into the circuit. The more deeply the patient breathes the faster they will establish a concentration gradient in the lung. It takes several minutes for the vessel rich group to be saturated and for expired concentrations to reach some sort of plateau. Once the therapeutic target end-tidal volatile concentration has been achieved then fresh gas flows can be reduced to maintenance values- this should be of the order of one litre a minute or less. This is principally for economic reasons.

Alterations in alveolar ventilation, cardiac output and FRC will affect the rate of wash-in. A shocked patient will approach equilibrium faster than a euvoelaemic subject and a lower initial dial setting should be selected. Children have a quicker induction time as alveolar ventilation is increased more than cardiac output. Pregnant women have a faster wash-in as although both ventilation and cardiac output are increased, they have a reduced FRC. Also an increased cardiac output will accelerate the saturation of the vessel rich compartment and decrease the alveolar to venous partial pressure difference.

On awakening when the vaporizer is turned off the concentration gradient is reversed. This is graphically represented by a wash-out curve. Emergence results primarily by eliminating the agent by exhalation. Metabolism plays a minor role as the current agents all undergo minimal metabolism. The less soluble the agent the faster it will wash-out as there is less agent to be eliminated. Increasing fresh gas flow (to prevent rebreathing of exhaled agent) and alveolar ventilation (accelerate agent removal) will enhance this process. It should be appreciated that even though administration of agent has ceased at the conclusion of an anaesthetic, tissue uptake of the agent continues because the larger, less well perfused tissues like muscle and fat haven't equilibrated. This will contribute to the fall in P_A until it equals P_T but is a relatively minor contribution with most anaesthetics as they aren't long enough to have lead to saturation of the compartments. Probably, the oft described concept of context sensitive recovery from anaesthesia is only of clinical importance for the more soluble agents like Isoflurane and relates to the degree of saturation of tissue compartments. A longer anaesthetic (the context) will fill the compartments with a larger reservoir of volatile which will come back into the blood as the concentration in the blood falls below that in the tissue. Desflurane will wash-out faster than Sevoflurane as expected but this is of dubious clinical significance as both will fall below the MAC-awake threshold within a minute of each other. The graph below shows the wash-out curves for a study involving morbidly obese patients given sevoflurane or desflurane. Both plateau below the 0.3 mark which is the MAC awake.

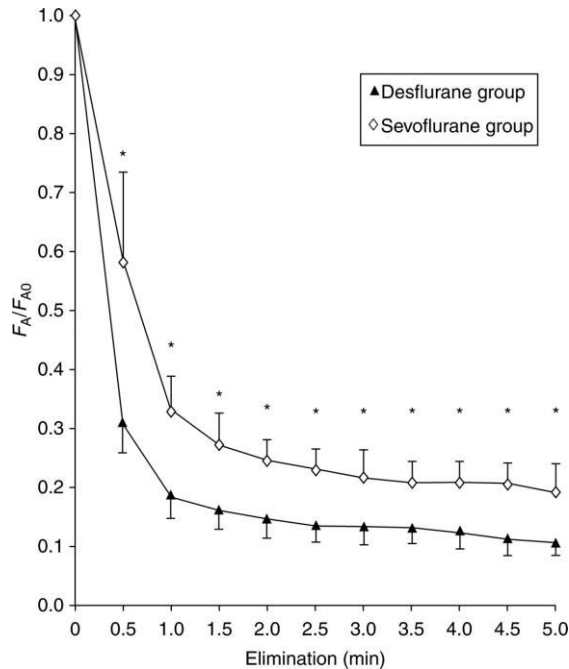
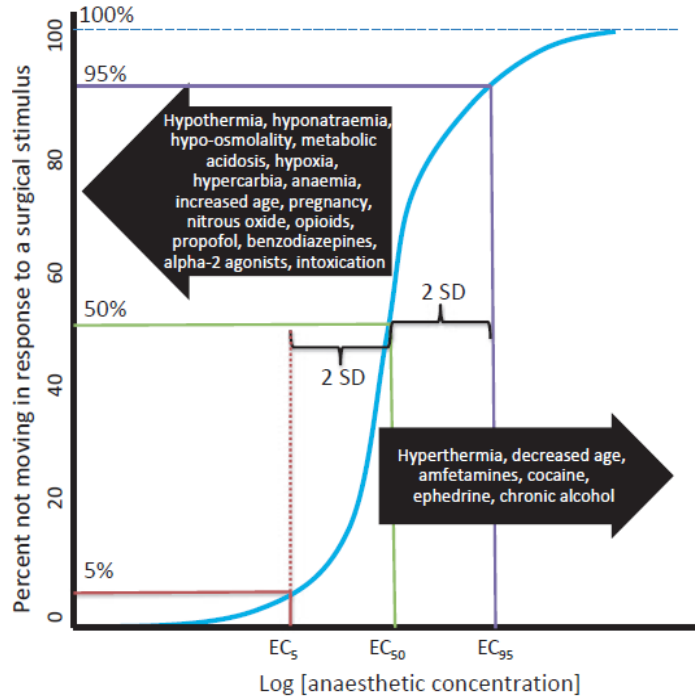

Figure 2 from L La Colla et al. Faster wash-out and recovery for Desflurane vs Sevoflurane in morbidly obese patients when no premedication is used. *British Journal of Anaesthesia* 2007; 99: 353-8. Used with permission.

Pharmacodynamics

Central Nervous System

Volatiles put you to 'sleep' and that is why we use them. They have complex effects on the brain and we still don't really know how they produce anaesthesia but they do- this will suffice for now. Unfortunately they also have important effects on other organ systems which are undesirable. Their ability to produce immobility is mostly due to actions at the level of the spinal cord. This brings us to the concept of MAC, arguably the most ubiquitous term in the world of anaesthesia. MAC, minimal alveolar concentration, is defined as the concentration of a volatile agent in 100% oxygen at equilibrium at atmospheric pressure that will prevent movement in response to a noxious stimulus (surgical incision) in 50% of subjects. Hence MAC is also an ED₅₀! MAC is used as a measure of the potency of a drug and they are inversely related. It should give you pause for thought that the criterion used to compare volatile anaesthetic agents and determine whether you are giving an 'adequate' anaesthetic is not related to depression of consciousness but to lack of movement! What is truly remarkable about MAC is that for any particular agent it has much the same value not just between individuals but even between species and types of animal. The MAC of Isoflurane for a worm, fish, cat, horse and human are all roughly the same! We will consider a population dose response curve for a volatile agent in some detail. The diagram also lists factors that increase and decrease MAC.



From A Aranake et al. Minimum alveolar concentration: ongoing relevance and clinical utility. *Anaesthesia* 2013; 68: 512-22

Before we consider the factors that affect MAC consider the curve itself. It is sigmoid shaped and the very significant thing about it is that it is *steep*. There is not a big increase in the dose from the EC_{50} (MAC) and the ED_{95} , in fact the EC_{95} is about 1.3 MAC. We can construct dose response curves for different responses that are perhaps of more clinical relevance like awakening (MAC-awake) and suppression of sympathetic response to surgery (MAC-Bar). If we superimpose these we get a diagram like the one below.

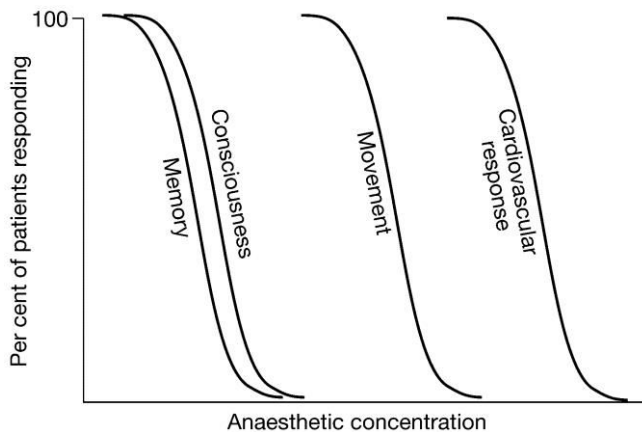

The most notable aspect which every anaesthetist should be very grateful of is the dose required for loss of consciousness is significantly less than that for the prevention of movement- it is less than 0.4 MAC for the agents in current use. Another very curious thing is that the MAC-awake and the MAC-unawake are not the same value. The concentration at which consciousness is lost on induction is in fact higher than the concentration at which patients regain consciousness on emergence. A hysteresis curve operates to describe this relationship. The magnitude of difference is quite small so is probably not clinically important. MAC-Bar is about 1.5 MAC for most agents.

There is a whole host of factors that affect MAC. Only some of them are listed on the diagram above. If a combination of volatiles are given or a combination of a volatile and nitrous oxide is given then their MACs are considered to be additive. Strictly speaking you can't have two vaporizers on simultaneously but you will have a mixture if you turn one off and another on. In practical terms all CNS depressants will decrease MAC, the most notable being the intravenous anaesthetic agents. Opioids decrease MAC in a synergistic fashion but have little effect on the level of consciousness- the patient doesn't move but they might remember it! If you were to construct an isobologram for MAC for Sevoflurane and fentanyl it would look something like the diagram below. If the two drugs were additive a straight line relationship would be demonstrated but instead a parabolic curve results as they act synergistically. Opioids markedly reduce MAC at relatively low concentrations but significantly don't eliminate the need for a volatile agent even at high concentrations.

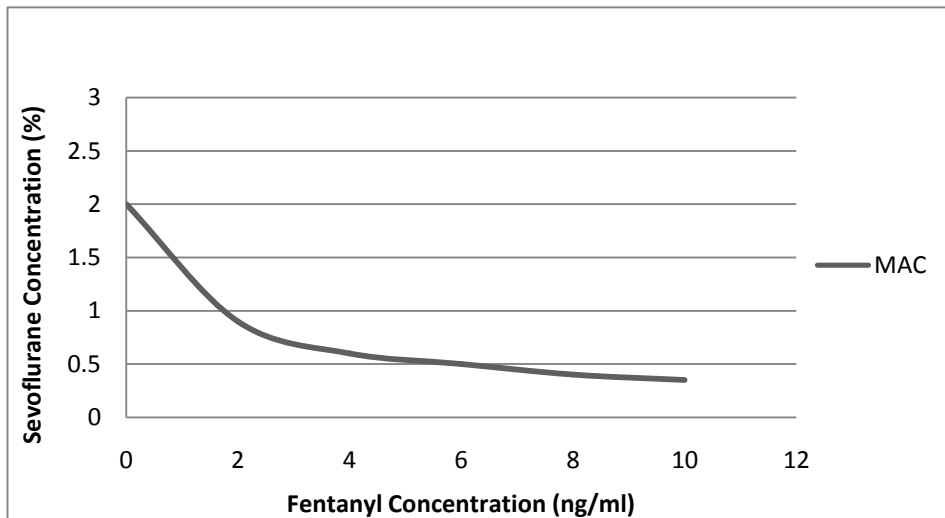

Apart from the drug interactions listed above the most important clinical ones are age and pregnancy. The MAC requirement for neonates is decreased and then it rises to a peak value around 12 to 18 months of age and then it steadily decreases by 6% per decade. Most anaesthetic machines will give you an age corrected MAC if you input the patient's age. The default setting is an assumed age of forty. Pregnancy decreases MAC by about 30%- this is predominantly a pharmacodynamic effect.

The volatiles do not have any analgesic properties with the exception of Methoxyflurane, hence its use by the ambulance service as an analgesic inhaler (Penthrane). The two anaesthetic gases, nitrous oxide and xenon, both have potent analgesic properties.

Respiratory System

The volatiles all cause dose dependent depression of ventilation by acting centrally on the ventilatory centre. Initially volatiles will cause an increase in respiratory rate and a decrease in tidal volume. As anaesthesia deepens the respiratory rate will fall until eventually apnoea results. This is seen at doses well above the usual therapeutic target, however, allowing maintenance of spontaneous ventilation during an inhalational induction. To understand their effect on the control of ventilation which is of great clinical importance requires us to consider another diagram which is reproduced below. The diagram comes from *Nunn's Applied Respiratory Physiology*.

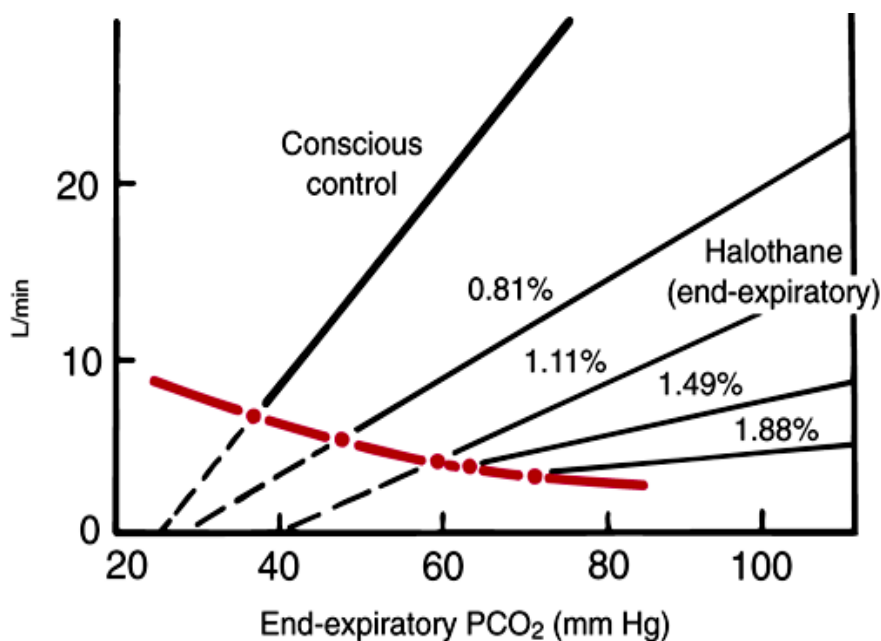

The diagram above illustrates the relationship between minute ventilation and end-expiratory carbon dioxide tensions (arterial CO_2 is very similar) for an awake subject as well as an anaesthetized subject at differing concentrations of a volatile anaesthetic which is Halothane in this case but the concepts are applicable to currently used agents. The red line joins the 'operating' points seen at equilibrium. Normally PaCO_2 is under very tight control and is the prime controlling parameter for ventilation. There is a steep, straight line curve response of the order of 2l/min ventilation for each mmHg increase in PaCO_2 . This is a very powerful response maintained over the physiological range of 20 to 80mmHg. The response is heightened (left-shifted) by acidosis, hypoxia and usefully for anaesthetists- surgical stimulation. The conscious control curve has been extended as a dotted line to meet the x-axis, the apnoeic threshold. Normally this doesn't actually happen and below about 20mmHg conscious individuals will hypoventilate but not actually become apnoeic. At the other end of the normal

curve, at above 80mmHg, the curve will plateau and then drop off as respiratory muscle fatigue and CO₂ narcosis supervenes. Note the effect of increasing concentrations of volatile is to right shift the curve and flatten it out. Also the curve operates right down to the apnoeic threshold. This means if you hyperventilate an anaesthetized subject below the threshold point they will stop breathing, unlike an awake patient. This is most commonly manifested at the end of a brief anaesthetic when the patient is taken off the ventilator and fails to breathe. The particularly astonishing thing is that the patient won't breathe even if they become profoundly *hypoxic*- this is totally abnormal physiology! This is because volatiles effectively ablate the ventilatory response to hypoxia at low, sub-anaesthetic concentrations. This is justification for the practice of administering supplemental oxygen to all patients during the emergence and early recovery phase from anaesthesia.

Volatiles obtund airway reflexes permitting instrumentation at concentrations above 1 MAC. They are all dose-dependent bronchodilators but there is reasonable reported and anecdotal evidence to suggest that Desflurane may increase airway resistance in patients with reactive airways or pre-existing elevated airways resistance. Certainly all agents smell unpleasant and can cause airway irritation manifested by coughing, laryngospasm and bronchospasm especially at high inspired concentrations. Desflurane is particularly prone to cause irritation when its concentration is rapidly increased. Desflurane also causes sympathetic stimulation in this instance (see below). All the volatiles impair hypoxic pulmonary vasoconstriction but this probably is of minor clinical significance.

Cardiovascular System

Volatiles cause dose-dependent depression of the cardiovascular system. They relax all smooth muscle including arterioles and venules and this accounts for their ability to cause hypotension. All the volatile agents produce dose-dependent depression of myocardial contractility and diastolic function. Like all negative inotropes the mechanism of this relates to an effect on intracellular myocardial cellular homeostasis. Not surprisingly, if you have pre-existing left ventricular impairment these drugs will depress it even further than the healthy subject. The systemic haemodynamic effects cannot be as easily described as those of propofol as they are the result of an interaction between effects on the heart, vasculature and autonomic nervous system. All agents decrease systemic vascular resistance and MAP. They all slow the rate of sinoatrial node discharge. Isoflurane and Desflurane tend to increase heart rate as a result of a relatively preserved baroreceptor reflex whereas Sevoflurane has little effect on heart rate unless given in high concentrations. Despite numerous textbooks banging on about the topic ad nauseum, volatiles (even Isoflurane) don't cause coronary steal at clinically used concentrations. They are all weak coronary vasodilators and exert myocardial protective effects which apart from imbuing one with a warm glow does not alter their clinical application.

Desflurane is unique in that rapid increases in its concentration cause sympathetic stimulation and this effect will dominate its haemodynamic actions in this event.

Cerebral Haemodynamics

To appreciate the effect of volatiles on cerebral haemodynamics, basic understanding of the relevant neurophysiology is required. A brief primer of the topic follows. The Monro-Kellie doctrine states that the cerebral contents are contained within a rigid box and if a component is

changed in volume this will exert an effect on intracranial pressure. The classic elastance curve of intracranial volume versus intracranial pressure (ICP) is reproduced below. Initial translocation of CSF counteracts a rise in pressure until a critical volume is reached. Cerebral blood volume accounts for about 10% of cerebral volume and is the focus of attention for the anaesthetist. Cerebral blood flow (CBF) is 750 mls/min, about 15% of CO and 50mls/100g brain tissue/minute. It is coupled to cerebral metabolic activity and is autoregulated over a MAP range of 65-150mmHg. Outside this range it is pressure dependent. As per Ohms law, flow (Q) is proportional to the pressure differential (P) divided by the resistance (R). In this instance, Q is CBF and P is the cerebral perfusion pressure (CPP) which is MAP minus the greater of ICP or CVP. CBF is also subject to chemical control. CBF varies directly with PaCO₂ over the range 25-70mmHg and increases 4% per mmHg rise in PaCO₂. Changes in CVR mediate these changes in CBF. Severe hypoxaemia causes a large increase in CBF. The relationships are graphically represented below.

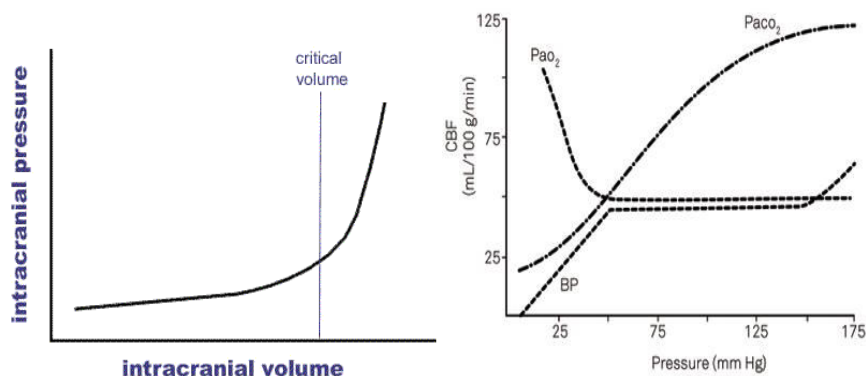

Anaesthetists can manipulate CBF by altering CPP and CVR. Vasopressors will increase MAP and CBF if below the autoregulatory threshold and have little effect if within the autoregulatory range. This range may be altered by neuropathology as well as by drugs which we will consider shortly. Anaesthesia and hypothermia decreases cerebral metabolic rate. Hyperventilation, through its predictable effect on PaCO₂, constitutes an eminently titratable and effective mechanism for anaesthetists to decrease CBF.

Now to the effect of volatiles. All of them suppress the cerebral metabolic rate (CMR) and will cause burst suppression on the EEG. At this point CMR is reduced by about 60% but further increases in volatile concentration don't cause further reductions in CMR. CBF is reduced due the fact that blood flow and metabolism are coupled. Unlike propofol, volatiles don't cause a parallel fall in CMR and CBF. Their net effect is a balance between reduced CBF caused by reduced CMR and increased CBF as a result of direct cerebral vasodilatation due to vascular smooth muscle relaxation. At low MAC, CBF is reduced, at 1 MAC there is little change and beyond this CBF is increased. Volatiles impair cerebral autoregulation and cause a left shift of the curve above and at high doses there is an almost linear relationship between CBF and volatile concentration. Fortunately volatiles have little effect on CO₂ responsiveness, i.e. it is preserved.

Sevoflurane is a slightly less potent cerebral vasodilator than Desflurane or Isoflurane. Desflurane decreases CMR to a lesser extent than Sevoflurane. Changes in CBF alter cerebral blood volume to a lesser degree but this is crucial in terms of the effect on ICP. In patients with abnormal intracranial compliance, impaired autoregulation or where drugs or conditions have already been given to suppress CMR then the administration of a volatile agent is assumed to predominantly cause cerebral vasodilatation and increase ICP. In conclusion, don't give smelly to a patient with a tight head.

Effect on other organ systems

Like suxamethonium, volatiles are triggering agents for malignant hyperthermia. They cause skeletal muscle relaxation and augment the action of neuromuscular blocking agents. They relax the uterus and decrease uterine blood flow but this is only significant at concentrations above 1 MAC. The reduction in renal blood flow matches the effect on systemic haemodynamics. Despite what the surgeons think, volatiles have no significant effect on the coagulation system. Volatile anaesthetics depress cell-mediated immunity. Having surgery is an immune suppressing event.

Nitrous Oxide

Nitrous oxide is a gas kept in liquid form in cylinders under very high pressure of the order of 70 atmospheres. The gas is piped to the anaesthetic machine at a pressure of about 4 atmospheres. The critical temperature of nitrous is 36.5 degrees so the cylinders are never fully filled- they always contain gas above the liquid phase. The pressure reading on a cylinder does not reflect how much nitrous is left in the cylinder. Although nitrous is a vapour at the ambient temperature of the operating theatre a cylinder can't really be termed a vaporizer because you can't adjust the concentration directly from the cylinder.

Although nitrous oxide has been used as an effective anaesthetic and analgesic agent for the last 150 years its use is very much on the wane. This is probably for no good reason. It is not a bad drug as such, many practitioners have chosen to use something in its place or more commonly omit it from their pharmacologic arsenal.

Nitrous oxide has a very different pharmacodynamic profile to the volatile agents described above. It also has a unique adverse effect profile. One of the notable differences is that it has a much higher MAC-awake of around 70%. See the table below. Because the maximum $F_I N_2O$ you can give is 70% (you need to leave some room to administer oxygen) this pretty much precludes using nitrous as a sole anaesthetic agent.

Agents	MAC*	MAC-awake*	MAC-awake/ MAC
Halothane	0.76	0.41	0.55
Isoflurane	1.15	0.49	0.38
Sevoflurane	2	0.62	0.34
Desflurane	6	2.5	0.34
Nitrous oxide	105	68	0.64

Earlier I said that when a volatile is given in combination with nitrous oxide that the effect on MAC is additive. Remember that MAC is defined by its ability to cause *immobility*. 50% nitrous + 1% Sevoflurane = 1 MAC but the effect in terms of depression of *consciousness* is not the same as 2% Sevoflurane which is also 1 MAC and this is different again to 105% Nitrous which is 1 MAC again (you'd need to be in a hyperbaric chamber to achieve this). Nitrous is certainly MAC-sparing but it is not nearly as reliable in terms of ensuring unconsciousness. Its minimal effect on BIS lends support to this statement.

As mentioned above nitrous is a potent analgesic but its rapid washout means this is useful only in the intraoperative phase of a procedure. It is safe to use in patients who are MH susceptible. It has minimal effect on ventilation but can significantly increase pulmonary vascular tone and should be avoided in patients with pulmonary hypertension. Although it is a myocardial depressant this is supervened by its relatively weak central sympathomimetic action. Generally blood pressure is maintained.

Adverse Effects

Nitrous increases the incidence of PONV. It supports combustion and should be avoided in laser surgery of the airway. Because it is about thirty times as soluble in blood as nitrogen it will diffuse into gas-filled spaces and expand these. Such spaces include the middle ear, a pneumothorax, gas embolus and the cuff of the endotracheal tube. In routine practice this is not of clinical relevance. At the end of an anaesthetic when inhaled agents are turned off there will be a considerable amount of nitrous exhaled in the first few minutes as it comes out of solution in the blood. This can be enough to dilute the oxygen in alveoli and cause the ubiquitous diffusion hypoxia. This is easily avoided by increasing the F_{iO_2} at the end of the procedure. In the ENIGMA study nitrous was associated with a significantly increased incidence of atelectasis and pulmonary complications but an association with increased adverse cardiac events and wound infections was not confirmed in the subsequent ENIGMA II study. Nitrous oxidizes the cobalamin cofactor in vitamin B12, this leads to reduced methionine synthetase activity. This can cause megaloblastic anaemia and subacute combined degeneration of the spinal cord. For this reason most clinicians avoid its use in long procedures and in patients undergoing repeated procedures, eg. ICU patients. Nitrous increases cerebral metabolic rate and cerebral blood flow and will increase intracranial pressure if $PaCO_2$ is not controlled. This effect is most marked when it is given as a sole agent. When administered with a volatile it will increase CBF whereas it has little effect when given with propofol. 50%

Nitrous plus 0.5 MAC volatile causes a significant increase in CBF compared to little change with 1 MAC of volatile. Nitrous Oxide is also a drug of abuse.

Practical Application

Nitrous oxide is predominantly used in anaesthesia as a volatile sparing agent. This enables a reduced dose of volatile to be given and consequently causes a reduced degree of cardiovascular and respiratory depression. This may be of benefit in elderly patients and those with cardio-respiratory compromise. Probably the most important advantage of this volatile sparing quality with routine anaesthesia is the cost saving especially when used in association with low fresh gas flows. A reduced dose of volatile also correlates with a faster emergence as less volatile has to be washed out and this is advantageous in short cases particularly if the patient is intubated, as in a paediatric ENT list for example. Nitrous oxide also provides analgesia that can be rapidly adjusted and it doesn't have to be signed out of the DD cupboard.

SELECTED REFERENCES

Minimum alveolar concentration: ongoing relevance and clinical utility. A Aranake et al. *Anaesthesia* 2013; 68: 512-22.

CHALLENGE QUESTIONS

1. Consider this washout curve of Desflurane and Sevoflurane again. Regardless of the volatile agent being used all washout curves demonstrate a relatively rapid and steep fall in alveolar concentration in the first minute or so once the vaporizer has been turned off and fresh gas flow cranked up. Can you explain what is going on here?

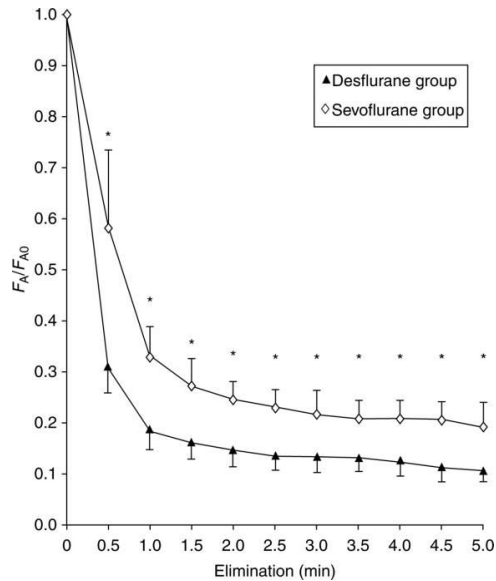

2. Methoxyflurane is a very soluble agent with a high blood gas coefficient of around 12. Consequently it has very slow wash-in and a high boiling point (105 degrees) means it has a very low saturated vapour pressure of only about 20mmHg at 20 degrees. How come it can be used effectively as an analgesic agent in a Pentrox inhaler?

ANSWERS

1. The measured end tidal expired concentration of volatile agent is used as the surrogate measure of the alveolar concentration. When the vaporizer is turned off and the fresh gas flow increased, volatile is quickly washed out of the circuit and this effectively empties the circuit of agent. This leads to a dilution of the agent in the lung as the concentration gradient is reversed favouring agent to come out of the blood into the lung from where it is exhaled into the circuit. Alveolar ventilation drives this process and this accounts for the initial large drop in end-tidal concentration. It is rapid as alveolar ventilation is usually relatively high if the patient is being mechanically ventilated and healthy lungs have a small time constant. The subsequent progressively slower elimination of the agent is due to washout from the vessel rich group and lastly from the poorly perfused fat compartment.
2. Methoxyflurane has an oil gas coefficient of 950 which means it is an extremely potent agent with a MAC of only 0.2%. It provides analgesia at subanaesthetic concentrations so only a small amount is required for it to be efficacious. Unlike the other volatiles it doesn't cause uterine muscle relaxation which is why it had a role in obstetric analgesia. Concerns with renal toxicity contributed to its declining clinical use.

Muscle Relaxants and Reversal

A surgeon's definition of anaesthesia is Vecuronium, an anaesthetist's is Propofol

You can't know too much about these drugs. Muscle relaxants are a core group of drugs for anaesthetists. We are pretty much the only practitioners that use these drugs on a regular basis and must be intimately familiar with every aspect of their pharmacology in order to use them safely and effectively. Propofol and relaxants are the drugs that will get you into trouble if you do not understand them well and even then experienced practitioners still experience adverse events with these agents. I would consider all this chapter core knowledge.

This chapter will address the following topics:

- How do these drugs work?
- Dose and timing of relaxants
- Considerations for the practical use of non-depolarizing muscle relaxants (NDMRs)
- Everything you need to know about suxamethonium
- Monitoring degree of paralysis including assessing reversibility
- Sensible use of reversal agents

How do these drugs work?

This necessarily involves a revisit of the physiology and pharmacology of the neuromuscular junction (NMJ). The sequence of events in normal neuromuscular transmission and muscle contraction is outlined below.

An action potential is propagated down the axon of a motor neuron in the anterior horn of the spinal cord>

The action potential travels to the presynaptic nerve ending at the NMJ>

This causes increased membrane permeability to Ca^{2+} via activating voltage gated channels>

There is release of about 60 vesicles each containing 10,000 molecules of Acetylcholine (Ach) via exocytosis (huge margin of safety)>

Ach diffuses across the synaptic cleft, about 50nm>

Ach binds to the alpha subunit of the nicotinic cholinergic receptor in the junctional folds of the postsynaptic membrane>

This receptor is a pentamer with 2 alpha units and one each of beta, delta and epsilon; Ach must bind to both alpha subunits to activate the receptor>

These ligand-gated ion channels open and allow $\text{Na}^+/\text{Ca}^{2+}$ in and K^+ out as they follow their concentration gradients maintained by the ubiquitous Na/K pump>

This generates a motor end plate potential and this activates fast voltage gated Na^+ channels in the perijunctional muscle membrane (this surrounds and abuts the motor end plate)>

If the threshold membrane potential of -50mV is achieved>

The action potential is propagated down the sarcolemma and t-tubules>

Voltage gated dihydropyridine channels are activated and Ca^{2+} enters from the ECF into the myocyte>

Ca^{2+} entry triggers further Ca^{2+} release from the sarcoplasmic reticulum via the ryanodine receptor>

Ca²⁺ binds to troponin C and subsequent excitation contraction coupling results in muscle contraction>

ACh in the cleft is very rapidly broken down by plasma acetyl cholinesterase and the choline is recycled. Diffusion of ACh away from the nicotinic receptor leads to cessation of action, normally the interaction between agonist and receptor is very brief; of the order of a millisecond.

Note that muscle relaxation is an active process.

Mechanism of action

All muscle relaxants are quaternary ammonium compounds and are structurally related to acetylcholine. They are highly water soluble, relatively large, basic compounds that are predominantly ionized at physiological pH as they have relatively high pKa's.

Non-depolarizing muscle relaxants (NDMRs) act simply by competitively antagonizing ACh at the postjunctional nicotinic receptor. They need to bind to only one alpha subunit to prevent ACh from activating the receptor. Again diffusion away from the receptor causes cessation of action. Non-depolarizers cause fade as a result of their binding to prejunctional receptors on the nerve ending. This binding prevents the normal positive feedback mechanism that the binding of ACh to these receptors facilitates. Instead of repeated nerve stimulation causing sustained quantal release of ACh, there is a progressive reduction in ACh release and fade results.

Depolarizing muscle relaxants, of which succinylcholine (suxamethonium or sux) is the only agent in clinical use, bind to the same subunit but their mechanism of action is significantly more complex. A necessarily detailed explanation follows.

Succinylcholine works by inducing accommodation blockade.

It actually binds as an agonist to the alpha subunit. Whereas the endogenous agonist ACh is happily chewed up by acetylcholinesterase as it diffuses away from the receptor, sux keeps on hopping on and off the receptor effectively activating it. Sux (and non-depolarizing agents for that matter) is not susceptible to acetylcholinesterase and so remains floating around in the NMJ so it can bind almost immediately to another postjunctional receptor.

So, if the sux keeps on hopping on and off the alpha subunit, how come that causes paralysis? We now need to look a little further away from the postjunctional receptor and remind ourselves that these ligand-gated ion channels are only found at the motor end plate. Surrounding and adjoining these are voltage-gated ion channels. These are present on the surface of the muscle membrane and account for the transmission of the action potential to the body of the muscle. *Appreciating the structure and behaviour of these voltage-gated sodium channels is crucial to understanding how sux works.* The sodium channel (see diagram) has two 'gates'- an upper m gate and a lower h gate. The m gate is voltage-dependent and the h gate is time-dependent. The conformation of these gates changes predictably with changes in the muscle membrane potential: at rest the m gate is shut and the h gate is open. With depolarization of the endplate the m gate opens (voltage-dependent) and after a short period the h gate spontaneously closes. With passage of a wave of depolarization and restoration of the resting membrane potential the m gate closes again and the h gate opens returning it to its resting state allowing it to be reactivated with a subsequent motor endplate depolarization.

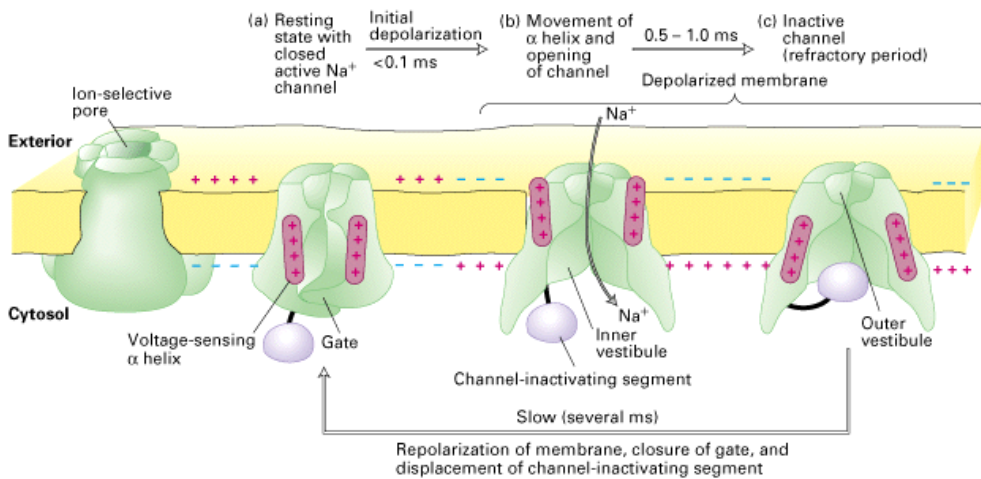

The 're-setting' of the gates in the sodium channel is dependent on a wave of depolarization passing through the membrane. This occurs with ACh but not with Sux as the ligand-gated ion channels are being continually activated and so the endplate remains depolarized. This means in the sodium channels ringing the endplate, the so-called perijunctional muscle membrane, the voltage sensitive m gate stays open (this accounts for the fasciculations seen with sux) but the h gate stays shut after its initial opening because it can't reset itself until the m gate closes.

The closed h gates in the perijunctional membrane sodium channels act as a barrier to further transmission of action potentials, i.e. this accounts for the paralysis.

I expect you will need to read this a couple of times to properly understand it. Below is a diagram from *Miller* (sixth edition) explaining it diagrammatically, it is the best description I have found.

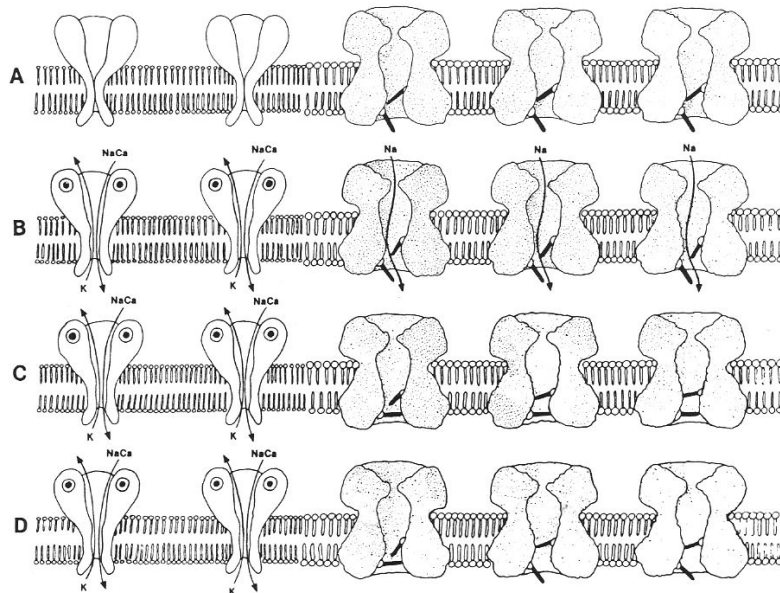

FIG. 25-10 Accommodation blockade. Molecules in the left two columns are receptors in endplate; chemically sensitive, voltage insensitive. Molecules in right three columns are sodium channels in muscle membrane; voltage sensitive, chemically insensitive. Appendages within sodium channels represent gates; top one is normally closed, but opened and held open when a voltage is applied across the membrane. Bottom one is "inactivation" gate; normally open but closes spontaneously soon after a voltage is applied across the membrane. Both gates must be open simultaneously if sodium is to flow through channel.

Sequence, top to bottom: (A) Resting membrane, no current flow through any molecule. (B) Agonist applied to endplate receptors; voltage developed by current flow through receptors causes gates in adjacent sodium channels to open. (C) Endplate still depolarized, but inactivation gates close. No current through sodium channel in third column, so no transmembrane voltage is developed and voltage dependent gates in last two columns close also. (D) Endplate still depolarized, so voltage dependent gate in sodium channel next to endplate remains open and inactivation gate closes. Gates in other two sodium channels return to resting positions. Inability of sodium channel in third column to respond to maintained depolarization of endplate causes blockade of neuromuscular transmission.

Dose and timing of relaxants

Muscle relaxants are initially distributed to the vessel rich group and then extracellular fluid as they are polar, water soluble molecules. They are poorly protein bound. NDMRs diffuse into the synaptic cleft down a concentration gradient to compete with Ach for binding sites. Sux behaves similarly however before it reaches the cleft a large amount of it (more than 80%) is metabolized by plasma cholinesterase. Note this is not the same as acetyl cholinesterase found in the cleft. So, to get paralysis a sufficient number of molecules must find their way to the synaptic cleft. Less potent compounds require more molecules to have the same clinical effect. A drug present in larger amounts will have a larger concentration gradient favouring its passage into the effect site. This is the main (but not only) reason why less potent drugs have a faster onset of action than potent ones.

It is crucial to appreciate the 'spare receptor' concept in neuromuscular transmission. There is a huge reserve in terms of how many receptors need to be activated to facilitate normal neuromuscular transmission. For this reason muscle relaxants must block a huge percentage of receptors before clinical effects are seen. For example a reduction in twitch height is not seen

until 75% of receptors are blocked and more than 95% of receptors must be blocked to facilitate intubation. This will be considered further in the section on monitoring the NMJ.

If you give a patient half the standard intubating dose of a muscle relaxant they will still be paralysed, the difference is it will take longer. In fact this is the equivalent of the ED₉₅! As anaesthetists we are almost as impatient as surgeons and so dosing regimens reflect our desire for rapid onset of profound paralysis. The three minutes waiting for the vec to work seems an eternity when everyone is in scrubs looking at you.

The priming principle takes advantage of the spare receptor concept- a small dose of NDMR is given prior to the conventional dose of relaxant in order to shorten the duration of onset of conditions suitable for intubation. The initial dose binds to enough receptors that they won't cause appreciable weakness to the patient but will necessitate fewer receptors to be blocked by the subsequent dose of agent. Similarly doses of NDMR given after the intubating dose should be greatly reduced, typically to about a quarter or a fifth of the intubating dose, because most of the receptors will still be occupied even though the patient's paralysis is 'wearing off'. Only a relatively small percentage of receptors need to be re-occupied to facilitate dense paralysis again.

Currently in Australia the following muscle relaxants are available:

Suxamethonium, rocuronium, vecuronium, cisatracurium, atracurium, mivacurium and pancuronium. I won't consider the latter further which can be thought of as long acting vecuronium with a modest sympathomimetic action. Atracurium is used infrequently in Australia.

We will consider their applied pharmacology in detail shortly but for now I will focus on dosing regimens.

Agent	Intubating dose	Onset time	Duration (mins)	Maintenance dose (mg)
Suxamethonium	1mg/kg*	circulation	3-9	n/a
Rocuronium	0.6mg/kg	90s	20-30	10-15
Rocuronium	0.9mg/kg	60s	30-40	Modified RSI
Vecuronium	0.1mg/kg	3 min	20-30	1-2
Cisatracurium	0.15mg/kg	3-4min	45	2-4
Atracurium	0.5mg/kg	2 min	20-30	5-10
Mivacurium	0.2mg/kg	3 min	15-20	n/a

*Many texts recommend higher doses in paediatric patients, when in conjunction with a rapid sequence induction and other contexts. This is unnecessary- 1mg/kg of sux is reliable in all circumstances.

You should know all the above numbers off by heart. Generally speaking your induction dose should be based on ideal bodyweight for obese subjects. There are formulas to calculate this but in practice very rarely is more than an ampoule of NDMR given (this is convenient for the lazy anaesthetists among us). If you have under dosed your patient the easiest fix for this is to wait a

bit longer before sticking the laryngoscope in. Finally I emphasize the point again that it is imperative to use objective methods (i.e. the nerve stimulator) to guide your use of muscle relaxants. The onset and duration of action times are just an approximation. There is huge inter-individual variability in the duration of action of all these drugs.

Cisatracurium unfairly gets a bad rap from some practitioners who say it ‘doesn’t work’ as their patient bucks when they attempt to intubate them. It is my observation that the same practitioners have not given an adequate dose (because this would necessitate opening a second ampoule) and they haven’t waited long enough before attempting intubation. Cisatracurium works fine.

Practical Use of the NDMRs

NDMRs can be classified on their duration of action and by their chemistry. Rocuronium and vecuronium are aminosteroid compounds. Cisatracurium, atracurium and mivacurium are benzylisoquinolines. Mivacurium has a short duration of action; atracurium, vecuronium and rocuronium have an intermediate duration of action and cisatracurium has a long duration of action.

Rocuronium and vecuronium are very similar drugs. Rocuronium is the most popular relaxant in the Western world. I unkindly suggest this is because it has a rapid onset of action and comes prepared as a ready to use solution. It has no advantages over vecuronium in pharmacodynamic terms. Both drugs are metabolized by the liver and excreted to a degree by the kidney as well as in bile. They have a similar duration of action and are both reliably antagonized by sugammadex. Neither causes histamine release and they are both very cardiovascularly stable. Vecuronium comes as a powder and its increased potency means it takes longer to work. A notable feature of rocuronium which is its major shortcoming is its marked variability in terms of its duration of action. It demonstrates a diurnal variability in this respect lasting up to 50% longer in the late morning compared to the afternoon. Biorhythms aside its duration of action is still more variable than that of vecuronium’s. Like propofol, rocuronium causes pain on injection. Most of our patients should be unable to complain about this but this should be considered as a contributor to withdrawal responses during injection of the agent. Rocuronium also has a higher incidence of causing anaphylaxis than vecuronium. It reliably precipitates when given together with thiopentone.

Cisatracurium undergoes unique metabolism that is termed ‘organ independent’. It predominantly undergoes Hofmann elimination, a form of spontaneous chemical degradation and to a lesser degree hydrolysis by plasma esterases. A small proportion undergoes renal elimination. Hofmann elimination is temperature dependent and for this reason cisatracurium is commonly stored in the refrigerator. Cisatracurium has very reliable pharmacokinetics and is the agent of choice for a muscle relaxant infusion. It is also very cardiovascularly stable. Because of its slow onset I usually administer it immediately before my induction agent. This effectively cuts a minute of waiting that would otherwise result if it is given after the induction agent. It has the lowest incidence of anaphylaxis of all the muscle relaxants. Atracurium consists of a mixture of isomers of which cisatracurium is one. Atracurium is less potent and

can cause histamine release so should be given slowly. Its metabolism is similar to cisatracurium but it undergoes a greater degree of ester hydrolysis.

Mivacurium, similarly to suxamethonium, is metabolized by plasma cholinesterase so is contraindicated in patients with scoline apnoea (see below). Although it has a short duration of action it has a similar onset of action time to vecuronium. It should be given over a minute to decrease the incidence of histamine release and in practice it would appear to have variable efficacy as a relaxant. Although it does not require reversal by neostigmine it has no other redeeming features.

In practice then, the choice is between roc, vec and cis and for most procedures any of these agents would be suitable. For a shorter procedure one would favour roc or vec and conversely cis for a long procedure. As I don't work in a hospital where sugammadex is on tap I favour vec for shortish procedures as its duration of action is more reliable. Rocuronium may be favoured for the patient who you anticipate difficult mask ventilation due to its more rapid onset but there are better management strategies for this problem (the patient will still desaturate if you fail to bag them for ninety seconds). Similarly, some practitioners may favour rocuronium because this gives them the option of rapidly antagonizing the agent with sugammadex (this is also nonsensical). Cisatracurium is the agent of choice for the patient with renal impairment or severe hepatic disease due to its organ independent metabolism.

Everything you need to know about suxamethonium

Suxamethonium (sux) is a depolarizing muscle relaxant and its mechanism of action was described above. The intubating dose is 1mg/kg and no other paralyzing agent is as reliable or works as quickly as it. It has the shortest duration of action of the agents and even high dose reversal of roc with sugammadex takes longer to restore ventilatory muscle activity in practice. It is not all good news, though. It has an extensive adverse effect profile and these mostly limit the use of the drug in practice. Let's consider these adverse effects in some detail:

- Fasciculations- this refers to the transient contractions of muscle groups visible as the drug is distributed to the effect site. While not harmful the beneficial aspect is we rely on them clinically to determine whether the sux has 'worked'. Fasciculations cause patient movement and are more marked in muscular subjects making optimum patient positioning important before giving sux. They have been implicated in sux myalgia- muscle aches usually experienced the following day with physical activity. They are self-limiting. Fasciculations do not always accompany the administration of sux and aren't necessary for the sux to have 'worked'.
- Bradycardia and other dysrhythmias- sux binds to the SA node and can cause a marked bradycardia. This is typically seen with a second dose of sux especially in children as they have higher resting vagal tone and so should be given with great caution in this instance or after pre treatment with an anticholinergic agent.
- Transient increase in intraocular and intragastric pressure- many textbooks advise caution in patients with penetrating eye injuries and the like but this is probably not warranted in

practice. The elevation is mild and transient and if the sux facilitates rapid and smooth intubation then this obviates the concern.

- Anaphylaxis- sux accounts for a disproportionate number of cases of anaphylaxis.
- Malignant Hyperthermia trigger- absolutely contraindicated in MH susceptible individuals.
- Masseter spasm- may be a prelude to MH if this is severe; 'jaws of steel'.
- Prolonged paralysis: phase 2 block- This is a poorly understood phenomenon seen in association with large doses of sux or infusions where the block behaves more like a non-depolarizing blockade.
- Prolonged paralysis: acquired causes of reduced plasma cholinesterase activity- there is a long list of conditions and drugs described but in practice they are rarely clinically significant. The exception is neostigmine which will reliably prolong its duration of action.
- Scoline apnoea- a classic example of pharmacogenomics in which genetically variable forms of plasma cholinesterase lead to impaired metabolism of sux and consequent prolonged duration of action. The four commonest forms of the allele are designated by the U.S.A.F. mnemonic: Usual (normal), Silent (absent), Atypical (dibucaine resistant) and Fluoride. Blood tests readily identify these variants. Patients homozygous for the atypical form of the gene, AA, are rare with an incidence of about 1/3000 but have a markedly prolonged duration of paralysis with a dose of sux for up to several hours.
- Abnormal response in muscle and neuromuscular disorders- a selected list of conditions and the nature of the abnormal response is below:
 - Muscular Dystrophy- sux is absolutely contraindicated in these patients. They have abnormal muscle membranes and have a marked hyperkalaemic response (see below) to sux including rhabdomyolysis.
 - Myaesthesia Gravis- resistant to sux and may be sensitive if treated with anticholinesterase drugs.
 - Myotonic Dystrophy- prolonged muscle contraction (myotonia) as well as sensitivity.
 - Eaton-Lambert Syndrome (prejunctional autoimmune disorder)- sensitive.
- Hyperkalaemia- this is the most important one because it can be fatal. Sux *normally* causes a transient increase in serum potassium of the order of 0.5 to 1 mmol/L. This is caused by efflux of potassium into ECF by depolarization of the nicotinic receptors. Note patients with renal failure have the same magnitude of potassium rise but they may have a higher resting plasma potassium concentration. There is a long list of conditions in which a much larger rise of potassium is elicited when the patient is given sux. These conditions share the same pathophysiological mechanism for this marked rise in potassium. They all have a marked increase in number of immature cholinergic receptors (also termed extra-junctional receptors because they are found outside the motor end plates and all over the muscle membrane) whose pentameric structure differs in having a gamma subunit in place of the adult epsilon subunit. These immature receptors are more sensitive to sux and when present in great numbers lead to a large, potentially lethal rise in potassium when sux is administered. Conditions that cause an increase in these receptors can be grouped as following:
 - Burns- related to the extent of burn, effect persists until complete healing of the burn has occurred which can take 18 months.

- Denervation- spinal cord injuries, motor neuron disease.
- Immobility- catatonia of any cause, bed-ridden patients.

In summary great caution should be exercised with the use of sux in any patient with a muscle disorder, neuromuscular disease, active neurological disease or anyone in the three categories described above. If in doubt don't use it.

Other uses of suxamethonium:

Sux is most commonly used to facilitate intubation as part of a rapid sequence induction (see Example Case 4). It is also used for short duration cases requiring paralysis, the classic example being electroconvulsive therapy. For ECT a reduced dose of 0.3 to 0.5mg/kg is sufficient and this will facilitate paralysis (and good intubating conditions as well, incidentally). Sux has a pivotal role in the management of laryngospasm that doesn't respond to other manoeuvres. In this situation a small dose, 10mg, is sufficient to 'break' the spasm. This small dose won't guarantee you good intubating conditions however, and often if the spasm is bad enough to require sux it is prudent to re-intubate the patient. Sux can be administered reliably intramuscularly to facilitate paralysis in instances where there is no IV access- the recommended dose is 2mg/kg into the biceps (close to the heart). Sux can be given as an infusion to facilitate paralysis of longer duration that will readily and completely resolve. This may be desirable for airway endoscopy cases for example.

Monitoring muscle relaxants and assessing reversibility

If you use muscle relaxants then objective monitoring of their activity is mandated. There is wide variability in their duration of action and residual paralysis has been compellingly implicated in the vast majority of adverse respiratory events in the postoperative care unit. This is a significant cause of morbidity which is potentially completely avoidable. In clinical practice incomplete reversal/ residual paralysis is more of a problem than inadequate paralysis. The surgeons would disagree but the latter problem is easily resolved with a further dose of relaxant.

In the monitoring chapter I described the modes of stimulation performed by the nerve stimulator- TOF, DBS and PTC. It is important to recognize that different muscle groups are affected differently by muscle relaxants. This is a result of their differing muscle structure, innervation and degree of vascularity. This has implications for monitoring. If we consider the diaphragm, adductor pollicis (what we usually monitor) and the laryngeal muscles then we can make the following points:

Onset of action is fastest in the diaphragm and laryngeal muscles and slower in the hand muscles but the diaphragm is the least sensitive muscle to relaxants whereas the laryngeal muscles and eye muscles are the most sensitive. The diaphragm recovers from paralysis more quickly than do the peripheral muscles. This means that if you monitoring the ulnar nerve that the laryngeal muscles will be paralysed before the nerve stimulator shows no twitches and on recovery the diaphragm will regain function before twitches are evident. Monitoring the facial nerve more closely correlates with the degree of paralysis of the laryngeal muscles.

Optimal use of the nerve stimulator entails applying it before inducing the patient and starting it once the patient is asleep but before relaxant has been given as it is painful. Very few people do this, laziness being the culprit. Once the supramaximal stimulus threshold is found most devices

will default to a TOF stimulation mode every 20 seconds. The moment when no twitches are visible correlates with the optimal time to intubate. With the return of 4 twitches on TOF consideration can be made whether a further maintenance dose of relaxant is necessary. In the majority of operations this is rarely required and if a further dose of relaxant is administered an appropriate 'maintenance' dose should be given which is about a quarter of the intubating dose. Again, this is because of the spare receptor concept.

The most important task though is assessing reversibility by neostigmine. Reversal is not required if the patient has adequate muscle strength as evidenced by the following criteria: TOFC of 4 with a TOFR of 0.9 or greater. Clinical criteria such as sustained head lift are not reliable. It would be reasonable to reverse a patient with a TOFC of two or more but I would wait at least 10 minutes since their last dose of relaxant as well as looking for clinical signs of return of muscle power. A patient with a TOFC of one or less is not reversible with neostigmine. Neostigmine has a ceiling dose of 70mcg/kg and is unable to adequately antagonize deep planes of paralysis. A PTC gives useful information in this scenario and a count of 10 or more correlates with a TOFC of one and that the patient will be reversible in ten minutes or less. The diagram below nicely displays this correlation for all the NDMRs in common use. Another option is to do a DBS- if they have two visible twitches then they are probably reversible with neostigmine.

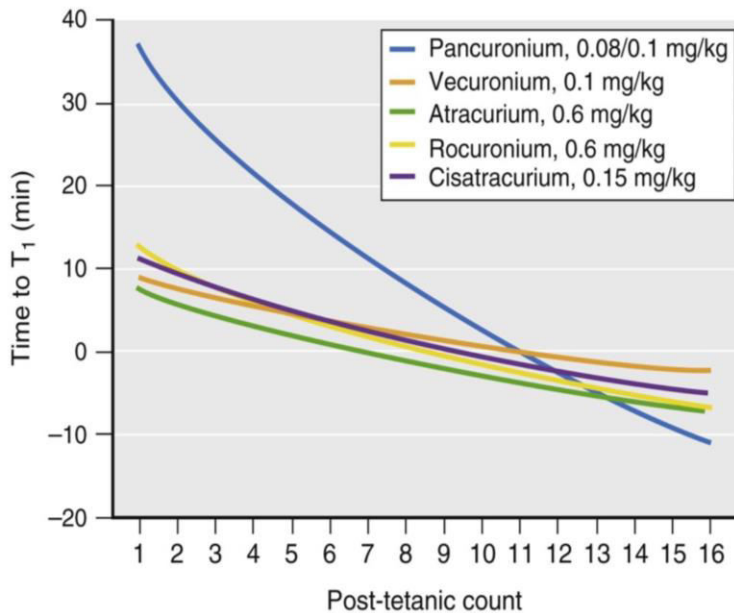

Figure 53-5 Relationship between the posttetanic count and time when onset of train-of-four (T_1) is likely to be elicited for various neuromuscular blocking agents. (From El-Orbany MI, Joseph JN, Salem MR: The relationship of post-tetanic count and train-of-four responses during recovery from intense cisatracurium-induced neuromuscular block, *Anesth Analg* 97:80, 2003.)

Sensible use of reversal agents

The commonest agent used to reverse a non-depolarizing muscle relaxant is neostigmine. This antagonizes the action of acetyl cholinesterase leading to an increased amount of Ach accumulating in the synaptic cleft and displacing NDMR from the nicotinic receptor. An anticholinergic drug is given in combination with neostigmine to prevent Ach interacting with muscarinic receptors and causing the well recognized cholinergic effects of bradycardia, nausea and vomiting, salivation and bronchospasm. The SLUDGEM acronym is useful to remember these: salivation, lacrimation, urination, defaecation, gut upset, emesis and miosis. The full dose of neostigmine is 50mcg/kg. Commonly we give an ampoule of this as our reversal; an ampoule contains 2.5mg which is probably an inadequate dose for a 100kg patient. Also be aware that neostigmine takes between six and ten minutes to achieve its peak effect. The anticholinergic agent used in combination with neostigmine is either atropine or glycopyrrolate. In practical terms there is little evidence base to favour one over the other.

Atropine will reliably cause a transient tachycardia as its onset of action precedes that of neostigmine. The dose is 20mcg/kg and as we usually give an ampoule (1.2mg) we usually overdose this agent slightly. A tachycardia is rarely of note in the sympathetically heightened environment that is the emergence period. Atropine crosses the blood brain barrier and has been implicated in the so called central anticholinergic syndrome. This is a rare syndrome that I have yet to encounter as a clinician. Glycopyrrolate requires two glass ampoules to be cracked to match an ampoule of neostigmine and is considerably more expensive. Two ampoules (400mcg) is a more evenly matched dose to that of neostigmine and more importantly its onset of action nicely matches that of neostigmine so the tachycardia is less prominent. Glycopyrrolate doesn't cross the blood brain barrier which makes some clinicians happier. It is a superior antisialogogue which may or may not be desirable depending on the circumstances.

You need to have a good reason *not* to give reversal. The criteria for adequate muscle strength and where reversal is not required are described above. A nerve stimulator is required to assess these criteria. If the patient is not reversible the best option is to wait.

Sugammadex

A fantastic drug that unfortunately still costs a fortune. It reliably and swiftly antagonizes blockade caused by rocuronium and vecuronium without the attendant problems of anticholinesterases and anticholinergics. The dose for reversal of partial blockade is one ampoule! (Well it is 2mg/kg which equates to a 200mg ampoule for most patients.) In the context of cost effective use of this agent, some appropriate indications for sugammadex are:

- When rapid complete reversal of blockade is desired.
- When there is residual blockade despite the use of anticholinesterase.
- Where optimal muscle strength is desired, eg. Morbidly obese patient who has had airway surgery.
- In circumstances where anticholinesterase is unlikely to achieve adequate reversal eg. Deeper planes of paralysis, renal failure, neuromuscular disease.
- Where don't want to use anticholinesterase eg. Bronchospasm, severe PONV.

- It has been suggested to administer it in the event of anaphylaxis due to vec or roc but this should not delay conventional first line therapy with adrenaline. The limited experience to date suggests it is unhelpful and indeed there are reports of anaphylaxis to Sugammadex itself!

To summarize: safe and effective use of muscle relaxants mandates the use of a nerve stimulator. The commonest error made by clinicians is not to use one. The dose and timing of these agents needs to be precise. Reversing a patient who is not 'ready' exacerbates the problem and the PTC is the most useful mode to guide the timing of reversal in the patient with a poor TOF response.

CHALLENGE QUESTIONS

1. Describe optimal clinical use of the GE quantitative nerve stimulator. (This should be revision.)
2. You have recently finished a tonsillectomy. The patient was paralysed with rocuronium and reversed with sugammadex. Now they are bleeding in PACU and they need to go back to theatre. What muscle relaxant can you use?
3. How can you intubate an adult safely and reliably without the use of muscle relaxants?
4. What's an easy way to give the correct dose of reversal for a child?
5. Why do septic patients appear to have increased muscle relaxant dose requirements?
6. Interpret this investigation.

Cholinesterase (plasma)	2.1	kU/L	(4.3 - 10.6)
Dibucaine number	19		(79 - 84)
Fluoride number	83		(86 - 91)

ANSWERS

1. Very rarely is this done but the recommendation is to apply the device *before* the patient is asleep. Once the induction drug is given but *before* the relaxant is given, start the device. Fifty milliamps sent to your wrist hurts. The device will find the threshold for a supramaximal stimulus and then perform a TOFC every twenty seconds. Give the relaxant after the first TOFC. The optimal time to intubate the patient is when the TOFC is zero. After intubation, adjust the timing interval to every five minutes or so and give further doses by determining objectively whether there is return of function. The patient should have a TOFC of four before giving further relaxant. At the end of the case, determine if the patient is reversible. They should have a TOFC of two or a PTC of ten at a minimum. The patient shouldn't be extubated until their TOFR is 0.9 or greater.
2. You can use sux as long as they don't have scoline apnoea or some other contraindication. You can also use cisatracurium or mivacurium but in the circumstances a RSI with sux would be appropriate. Small clinical studies suggest that you can actually give rocuronium again after only five minutes post sugammadex (4mg/kg) but it will have a longer time of onset of about three minutes and not last as long. Other options are discussed below.
3. This is necessary in some uncommon scenarios: patient has multiple allergies; patient has neuromuscular disorder where you want to avoid a relaxant; want to keep the patient breathing spontaneously. You can just give a big slug of induction agent but it will not be pretty and I don't recommend it. The commonest method entails giving a short acting opioid- 15 to 20 mcg/kg of alfentanil or 4 mcg/kg of remifentanil and intubating sixty seconds later. If you want your patient to keep breathing then performing a gas induction or a slow induction with Propofol TCI and waiting for them to be 'deep' followed by topicalizing the glottis with local anaesthetic is a well recognized and effective technique. Of course the other option is to perform an awake fiberoptic intubation!
4. Draw up an amp of neostigmine and an amp of atropine and some saline to a total volume of 5mls. Give 1ml of this per ten kg bodyweight. This equates to 20mcg/kg of atropine and 50 mcg/kg of neostigmine. Alternatively, sugammadex is licensed in children aged two or more.
5. This is one of those questions that is hard to find a definitive answer for in the literature despite it being a well recognized phenomenon. Consequently my 'answer' is more speculation than fact. Septic patients have increased circulating concentrations of acute phase proteins including alpha-1 acid glycoprotein (AAG) which binds some drugs including opioids and muscle relaxants. Less free drug means less to interact with the nicotinic receptor. These patients also have hyperdynamic circulations and an increased cardiac output which facilitates an increased degree of redistribution and clearance of the drug.
6. This is consistent with scoline apnoea. The patient is homozygous for the atypical form of the gene and would be expected to have prolonged paralysis if given succinylcholine.

Analgesics, Antiemetics and Local Anaesthetics

ANALGESICS

The focus will be on their clinical application in the perioperative environment. Knowledge of the pharmacology of these drugs is helpful to determine the choice of agent. Good knowledge of the relative contraindications of specific agents is expected of the doctors who administer them.

Opioids

The adverse effect profile of these drugs is well described and known. There is no convincing evidence for a difference in the incidence of PONV between individual opioids. Patients do not develop tolerance to the constipating or miotic actions of these drugs. They are all efficacious for the treatment of perioperative pain. Efficacy is not a valid criterion when selecting a specific opioid contrary to the nonsense some drug reps espouse. The mu receptor does not discriminate. There is very sparse quality evidence to assist the anaesthetist in making the necessary selection of “Which opioid will I give this patient?” ANZCA’s *Acute Pain Management: Scientific Evidence* attempts to rectify this deficiency but mostly fails due to lack of evidence. I find reading a few chapters of this 700 page plus tome will reliably induce a personal sedation score of 2. Nevertheless many practitioners harbour strong preferences for opioid A versus opioid B. I recommend a healthy degree of scepticism to be exercised in this instance. Don’t be afraid to ask your boss why they have selected drug X and it is not unreasonable to expect an answer that extends beyond “I just like this one.”

Some notes on specific agents are presented below. I have kept these brief. Just as there is huge inter-individual variability in the dose-response relationship for opioids, a similar spectrum of variability is represented in textbooks in terms of pharmacokinetic data for these drugs.

MORPHINE- the gold standard. The opioid most likely to cause histamine release and it not uncommonly causes itch and wheals. It has metabolites that accumulate in renal failure, morphine-6-glucuronide is an active metabolite and morphine-3-glucuronide is considered to be pro-convulsant.

OXYCODONE- The drug that is given to patients who claim to be allergic to morphine. Oxycodone is more potent than morphine, 5mg of parenteral oxycodone is equivalent to about 8mg of morphine. It causes less itch and is more expensive. The immediate release oral formulation, endone, is the favoured oral opioid analgesic of the contemporary anaesthetist. Oxycodone formulations are the most abused prescription medication in the world. Targin is the brand name of a combination of sustained release oxycodone and naloxone. It is considered to have a decreased rate of constipation. Oxycodone shouldn’t be used in patients with severe renal impairment.

FENTANYL- Mr Reliable, probably the most used opioid by anaesthetists (both for their patients and themselves!). It also has a metabolite that accumulates in renal failure yet is the opioid of choice for the patient with renal failure as it isn’t active. Fentanyl has an effect equilibration time of about six minutes, which is significantly less than that of morphine. It has

a large volume of distribution being a lipid soluble drug so if given in large amounts or as an infusion it will accumulate and cause a prolonged pharmacodynamic effect.

ALFENTANIL- Essentially fentanyl that costs more but doesn't last as long. It reliably reaches the effect site 60-90 seconds after it is given which is handy to obtund the pressor response to intubation and the laryngospasm response to having your anal sphincter stretched by the surgeon.

REMIFENTANIL- An eminently titratable, short acting opioid that necessitates having a syringe pump. Like alfentanil it will hit the effect site in a minute but it has a context *insensitive* half time of 4 minutes meaning it does not accumulate. This also means you need to give a longer acting opioid to cover it when it is switched off. Curiously if you don't do this it can actually cause hyperalgesia. I don't think anyone really knows why but it may be an acute form of tolerance. It is commonly given with propofol TCI to provide analgesia and decrease the required dose of propofol. It will reliably decrease heart rate and blood pressure if you give enough and muscle rigidity if you give too much.

BUPRENORPHINE- a partial agonist that acts as an agonist in the vast majority of clinical scenarios where it is used by anaesthetists. Its pharmacokinetics are not changed in renal failure. It reportedly has a ceiling effect for respiratory depression but not for analgesia- see the diagram below. The fact that it still causes significant respiratory depression often escapes the attention of the prescribers of this drug. The sublingual preparation has about 50% of the efficacy of the parenteral formulation and is a handy step down option for patients whose absorptive tracts aren't working properly.

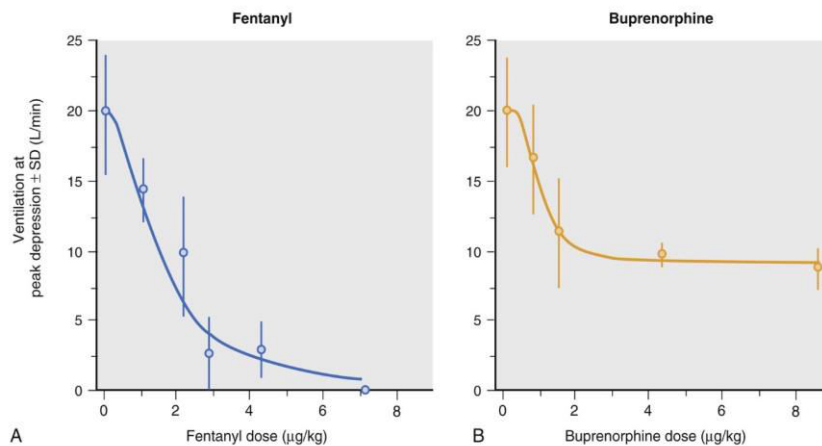

Figure 31-26 Dose-response relationships for reduction of minute ventilation induced by fentanyl (A) and buprenorphine (B). The response is the peak ventilatory depression at each dose. The line through the data is the fit to the Hill equation. Placebo is 0 µg/kg. Data are mean ± standard deviation.

(From Dahan A, Yassen A, Bijl H, et al: Comparison of the respiratory effects of intravenous buprenorphine and fentanyl in humans and rats, *Br J Anaesth* 94:825-834, 2005.)

Used with permission

HYDROMORPHONE- A highly potent drug, five times that of morphine. If your patient is on this they probably already have a significant degree of tolerance to opioids.

TRAMADOL- Has similar potency to pethidine but doesn't make you feel good like it does and consequently has a reduced potential for abuse. Has oral immediate and sustained release formulations. It acts via a combination of mu receptor agonism as well as being serotonergic and inhibiting noradrenaline reuptake. Ondansetron supposedly decreases its analgesic efficacy being a serotonin antagonist. It makes some people sweaty and twitchy. They are less likely to get sick with it if it is given slowly intravenously, i.e. squirted in the IV fluid bag. I would avoid it if the patient was taking multiple aminergic drugs (eg. tricyclic antidepressant, valproate) but not if they were just on a SSRI alone. Every other patient is on a SSRI yet serotonin syndrome is incredibly rare. I would also avoid it in patients with epilepsy and renal failure. Tramadol has proven efficacy in neuropathic pain.

TAPENTADOL- A relative newcomer in Australia. It only comes as a sustained release formulation. It is a mu agonist and inhibits the reuptake of noradrenaline centrally. It is said to have a decreased rate of adverse gastrointestinal effects compared to pure mu agonists.

PETHIDINE- Unique in that as well as its opioid action it also has local anaesthetic and anticholinergic actions. It causes mydriasis and tachycardia unlike other opioids and may be less likely to cause spasm of the sphincter of Oddi. It can provide anaesthesia when injected neuraxially as a sole agent. Its use has been mostly abandoned because of its abuse potential. Its main metabolite norpethidine accumulates in renal failure and can cause CNS stimulation manifesting as seizures and delirium.

CODEINE- A low potency drug with variable patient response due to its metabolism. It possesses superior constipating qualities. The polymorphic enzyme Cytochrome P450 2D6 (CYP2D6) is important for the drug metabolism of codeine, tramadol and oxycodone. Poor metabolizers whose enzyme form has minimal CYP2D6 activity have a decreased analgesic response to these drugs although oxycodone seems to be less of a problem. Ultrarapid metabolizers have increased activity of their CYP2D6 and are at increased risk of codeine and tramadol toxicity. This has been implicated in the deaths of children who have been given codeine preparations postoperatively after tonsillectomy. 10% Caucasians are poor metabolizers and 5% are ultrarapid metabolizers whereas 30% of Middle Eastern and North African populations are ultrarapid metabolizers.

Non-Opioids

PARACETAMOL- A well tolerated drug that comes in an intravenous formulation that costs over a hundred times as much as the tablet. Its analgesic mechanism of action is still not clearly elucidated. It is a weak analgesic at best. Its oft praised opioid-sparing qualities do not translate into less opioid adverse effects. Hepatotoxicity due to therapeutic dosing is incredibly rare even in those with liver impairment.

NSAIDS- These are superior analgesic agents to paracetamol and also have anti-inflammatory actions. Oral and intravenous formulations are available. The former is cheaper but not as satisfying to administer. There is no convincing evidence these drugs impair bone healing. Parecoxib is a COXII selective parenteral agent that anaesthetists have embraced. Unlike non-selective NSAIDs parecoxib doesn't impair platelet function (i.e. doesn't cause bleeding) but should be assumed to have a similar adverse effect profile to NSAIDs in terms of effects on the kidney and to a lesser extent on the GIT. Parecoxib shouldn't be given to patients with a

sulphur allergy as it contains a sulphur moiety. Coxibs don't increase the incidence of adverse cardiovascular events in non-cardiac surgery. NSAIDs can be used safely with the vast majority of asthmatics, particularly the ones that smoke. I would not use NSAIDs in the following patient groups:

- Pregnant- Category C, tocolytic, causes premature closure of the ductus arteriosus.
- Patient with aspirin sensitive asthma
- Known gastric ulceration
- Patient with renal impairment- elderly, septic, CKD, critically ill, hypo-volaemic, pre-eclamptic.
- Surgeon has requested not to use them- this is the commonest reason in my paediatric practice.

GABAPENTIN/ PREGABALIN- Not recommended unless the patient is already taking them. They will more reliably cause somnolence and dizziness than analgesia in the recovery unit.

CLONIDINE/ DEXMEDETOMIDINE- Alpha 2 agonists that act predominantly via central effects. Dexmedetomidine is slow acting and needs to be given by infusion and titrated to effect. Clonidine is particularly useful in the patient who is hypertensive and has been given a lot of opioid as it works synergistically with these agents and is a sympatholytic drug. They have most effect if there is sympathetic overactivity but little if this is absent. They can cause sedation and bradycardia. Clonidine is probably the drug of choice to treat shivering (unless the patient is having a rigor).

KETAMINE- See the *Thiopentone and Ketamine* chapter for a treatise about this versatile drug.

Number Needed to Treat (NNT) Table

Some information to ponder is presented below. The NNT 50% is the number of patients required to be treated for one of them to obtain a 50% reduction in pain compared to a placebo. This is considered to be an effective result in the pain world. Remember that placebos themselves generally are reported to have a 15-20% response rate which is not inconsequential.

NNT 50% for assorted oral formulations

Most NSAIDs	2-3
Paracetamol 1g	4
Tramadol 100mg	5
Oxycodone 15mg	4.5
Oxycodone+ Paracetamol	2-4
Tramadol + Paracetamol	2-3
Oxycodone 5+Ibuprofen 400	2.3
Codeine 60mg	12

Curiously a Cochrane review which is considered as level 1 evidence reported that 5mg of immediate release oxycodone is no better than placebo for the treatment of moderate to severe acute pain! (This makes no sense to me.)

Patient Controlled Analgesia (PCA) with opioids

Even ANZCA's *Acute Pain Management: Scientific Evidence* acknowledges that there is no significant difference in the risk of adverse effects amongst the opioids. Real world experience tells us that some patients tolerate a particular opioid better than another one giving rise to the popular practice of opioid rotation. What some trainees are reluctant to accept is that some patients don't tolerate any opioid well. Adverse effects are generally dose-related so you are more likely to see them when doing the pain round. Respiratory depression is the most concerning adverse effect for patients receiving opioids 'on tap' on the ward because it can be lethal. Opioid induced ventilatory impairment (OIVI) is the favoured nomenclature for this entity. Sedation is the best early sign of respiratory depression. As a wise intensivist once said "the brain is the most important organ of respiration". The disappointing majority of morbid OIVI is diagnosed retrospectively after a MET call has been made. The obese patient with obstructive sleep apnoea is readily identifiable as being at high risk of OIVI. If these patients are given a PCA the choice of specific opioid is immaterial- it is ensuring the patient is cared for in an appropriately monitored environment that is paramount. The use of oral NSAIDS (but not paracetamol) with opioids does reduce the rate of PONV by about 30% but doesn't alter other outcomes, notably OIVI. Curiously perioperative IV paracetamol does reduce the incidence of PONV.

ANTIEMETICS

Antiemetics or antispews as I like to call them are as ubiquitous to most anaesthetics as fentanyl. Apfel's criteria remain the most commonly used to determine whether prophylaxis with antiemetic drugs is indicated. They are equally weighted and have been validated in numerous large trials. I commend them to your hippocampus. Note the baseline incidence of PONV with no risk factors is 10% which is not inconsiderable.

Risk Factor	Points	#Risk Factors	%Risk PONV
Female Gender	1	1	20
Non-Smoker	1	2	40
Hx PONV/Motion sickness	1	3	60
Postoperative Opioids	1	4	80

The antiemetics have been studied extensively and there are very few unknowns with these drugs. There are multiple guidelines in circulation to guide their use. Arguably the most meritorious of these is that of SAMBA, the Society of Ambulatory Anesthesia. I will summarize their recommendations for you: An effective dose of antiemetic reduces the predicted incidence of PONV by approximately 20%. Ondansetron has a NNT of 6. For very high risk patients use three antiemetics from three different classes. For high risk patients use two agents, a combination of dexamethasone and a 'tron' being the favoured one currently. For rescue therapy use a drug from a different class.

Metoclopramide is not recommended by SAMBA. I will refrain from delivering my usual tirade about Maxolon, suffice to say that it has no place in contemporary anaesthesia. The Australian

TGA specifically precludes it from being given at a dose that actually works. Trons are cheap and more effective versus emesis than nausea. 4mg IV ondansetron is equivalent to the 8mg wafer. Dexamethasone is a more effective anti nausea agent and in high dose (8mg) also enhances the quality of recovery and analgesia. The commonest adverse effects of trons are headache and constipation. Many practitioners give a tron at the end of anaesthesia because some have a short half-life. This practice has the inherent risk of forgetting to give the drug at all. Single dose dexamethasone therapy is safe and unlikely to significantly affect glycaemic control of diabetics nor increase the risk of a surgical site infection (PADDI trial pending) nor make your femoral head necrose. It has been reported to cause perineal pain when given to awake female patients- go figure. All the antiemetics cause prolongation of the QT interval but droperidol got a black box warning from the FDA for its efforts. I use it as a third or fourth line drug because of its ability to cause hypotension and the rare but very unpleasant 'locked-in' syndrome. Avoid dopamine antagonist drugs in patients with Parkinson's and those who've had a dystonic reaction in the past. Chlorpromazine is the ultimate antiemetic. Its efficacy probably relates to the fact that it renders most people incapable of complaining about their nausea. It is a potent vasodilator as well as tranquilizer. The use of propofol as a maintenance anaesthetic is equivalent to one and a bit antiemetic agents- not enough to warrant the use of TIVA as a default anaesthetic technique in this respect when it can be matched by 40 cents worth of ondansetron. The graph below is from Apfel et al's huge IMPACT study comparing the rate of PONV with different anaesthetic regimens. Volatile+air+two agents compares very favourably to TIVA+two agents!

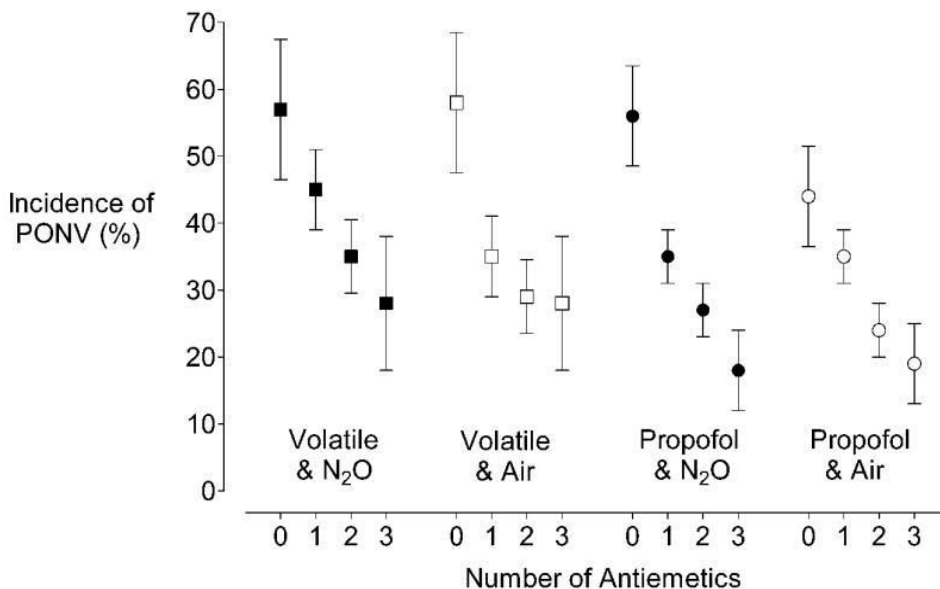

LOCAL ANAESTHETICS

Local Anaesthetics (LA) work by blocking voltage gated sodium channels. Their important therapeutic and adverse effects are related to channel blockade of nerve and brain tissue and heart muscle. LA's are weak bases. They are usually formulated as HCl salts in aqueous

solution. The pKa of a drug is the pH at which 50% of the base drug is dissociated into its charged, cationic form. As pH is lowered below the pKa these drugs become more dissociated and a larger proportion of charged molecules results. The charged form is less lipid soluble and is slower to penetrate tissue membranes. This is one of the reasons why local doesn't work as well in infected tissues because of the anaerobic, acidic environment. There are only three local anaesthetics used regularly by anaesthetists in Australasia- lignocaine, bupivacaine and ropivacaine.

The table below contains information that is to be committed to memory.

Drug	pKa	Max dose plain	Max dose + adrenaline	Maximum infusion rate
Lignocaine	7.8	3mg/kg	7mg/kg	1-2mg/kg/hour
Bupivacaine	8.1	2mg/kg	2mg/kg	0.4mg/kg/hour
Ropivacaine	8.1	3mg/kg	3mg/kg	0.4mg/kg/hour

Surgeons often ask us how much local they can use. Although the response "You should know" is perfectly legitimate, it doesn't help the cause. To answer your surgeon's query requires some simple maths that doesn't necessitate an iphone to calculate.

A 1% solution contains 10mg per ml of solution. A 2% solution contains 20mg per ml and a 0.5% solution contains 5mg per ml. LAs come in the following formulations: Lignocaine 1 and 2% with and without adrenaline; Bupivacaine 0.25 and 0.5% with and without adrenaline; Ropivacaine 0.2, 0.75 and 1% plain solutions. Maximum doses should be calculated based on ideal bodyweight not actual bodyweight if the patient is obese. If a combination of agents is used then their combined toxicity must be considered. This is analogous to the summative MACs of volatile agents.

Some example cases:

- 1) 20kg child for wound infiltration with 0.25% bupivacaine. This contains 2.5mg/ml, most clinicians accept 2.5 is close enough to 2 so the maximum dose is the child's weight in mls, i.e. 20mls. The presence of adrenaline doesn't change the calculation. This is easy to remember for paediatric surgery and is probably why it is the favoured solution in this group.
- 2) 20kg child for wound infiltration with 1% ropivacaine. Maximum dose is 3mg/kg, which is $3 \times 20 = 60\text{mg}$. So 6mls is the answer. I discourage the use of 0.75% ropivacaine to make my calculations easier!
- 3) 130kg adult for a brachial plexus block with 2% lignocaine with adrenaline. Work on an 'ideal' bodyweight of 100kg. Maximum dose is 7mg/kg which is 700mg. This equates to a substantial 35mls of LA- almost 2 whole amps.

In practice, as long as the surgeon isn't injecting the local into the newly sited portacath they can safely give a 20ml amp of local to virtually everyone with the notable exception of 0.75% and 1% ropivacaine.

Cardiotoxicity

Bupivacaine and ropivacaine bind more tightly to cardiac muscle sodium channels than lignocaine and this is why they are more worrisome agents in the setting of systemic toxicity. This is also why they are contraindicated for intravenous regional anaesthesia. The management of cardiovascular collapse induced by LA toxicity has been revolutionized by the introduction of intralipid therapy in the last decade. The ANZCA endorsed UK guideline is below. The initial bolus dose of intralipid is 1.5ml/kg and can be repeated twice if the patient is still unstable. Ropivacaine is less potent than bupivacaine but is probably equally cardiotoxic when given in equipotent doses. Astra-Zeneca neglected to acknowledge this when they introduced the drug in the nineties (they monopolized the market). There are reported cases of tachyphylaxis developing to patients receiving ropivacaine infusions, the aetiology is unclear. There are no convincing reasons to favour the use of levobupivacaine (this is the s-enantiomer of bupivacaine) over bupivacaine.

<h2>1</h2> <h3>Recognition</h3>	<p>Signs of severe toxicity:</p> <ul style="list-style-type: none"> • Sudden alteration in mental status, severe agitation or loss of consciousness, with or without tonic-clonic convulsions • Cardiovascular collapse: sinus bradycardia, conduction blocks, asystole and ventricular tachyarrhythmias may all occur • Local anaesthetic (LA) toxicity may occur some time after an initial injection 	
<h2>2</h2> <h3>Immediate management</h3>	<ul style="list-style-type: none"> • Stop injecting the LA • Call for help • Maintain the airway and, if necessary, secure it with a tracheal tube • Give 100% oxygen and ensure adequate lung ventilation (hyperventilation may help by increasing plasma pH in the presence of metabolic acidosis) • Confirm or establish intravenous access • Control seizures: give a benzodiazepine, thiopental or propofol in small incremental doses • Assess cardiovascular status throughout • Consider drawing blood for analysis, but do not delay definitive treatment to do this 	
<h2>3</h2> <h3>Treatment</h3>	<p>IN CIRCULATORY ARREST</p> <ul style="list-style-type: none"> • Start cardiopulmonary resuscitation (CPR) using standard protocols • Manage arrhythmias using the same protocols, recognising that arrhythmias may be very refractory to treatment • Consider the use of cardiopulmonary bypass if available <p>GIVE INTRAVENOUS LIPID EMULSION (following the regimen overleaf)</p> <ul style="list-style-type: none"> • Continue CPR throughout treatment with lipid emulsion • Recovery from LA-induced cardiac arrest may take >1 h • Propofol is not a suitable substitute for lipid emulsion • Lidocaine should not be used as an anti-arrhythmic therapy 	<p>WITHOUT CIRCULATORY ARREST</p> <p>Use conventional therapies to treat:</p> <ul style="list-style-type: none"> • hypotension, • bradycardia, • tachyarrhythmia <p>CONSIDER INTRAVENOUS LIPID EMULSION (following the regimen overleaf)</p> <ul style="list-style-type: none"> • Propofol is not a suitable substitute for lipid emulsion • Lidocaine should not be used as an anti-arrhythmic therapy

SELECTED REFERENCES

A Factorial Trial of Six Interventions for the Prevention of Postoperative Nausea and Vomiting, Apfel et al. *New England Journal of Medicine* 2004, 350: 2441-51.

Consensus Guidelines for the Management of Postoperative Nausea and Vomiting, T Gan et al. *Anesthesia and Analgesia* 2014; 118: 85-113.

Acute Pain Management: Scientific Evidence, edited by S Schug et al. ANZCA Fourth edition 2015.

The Main Event



Waiting for the patient to arrive...

Preoperative Assessment

Know what you're up against

Regretfully this is a rather dry topic but a very important one. It might be unkind to consider it a necessary evil but after doing a preadmission clinic (PAC) full of complex, cantankerous and crazy patients you will appreciate what I mean. The preoperative assessment routine will become second nature to you early in your anaesthetic term and it is vital you lock in 'good' habits from the start. This section endeavours to define those good habits. You will expend a lot of time and effort conducting preoperative assessments so it is important to be both efficient and accurate. The following topics will be addressed:

- Why preoperative assessment is important
- A proforma for preoperative assessment
- Preoperative Investigations
- Medication Management
- Routine Planning
- The 'emergency' or abbreviated assessment
- The 'risks' of anaesthesia

The vast majority of patients come in on the day of surgery. Most hospitals screen their patients with either a questionnaire or phone interview and selected patients are seen in a dedicated preadmission clinic. Patients may see a nurse, pharmacist, surgical resident and anaesthetist in clinic. PAC represents a dedicated environment that is appropriately resourced to conduct a preoperative evaluation. Time is the most valuable resource. Tasks other than completing the anaesthetic assessment are performed in clinic- specific preparations for theatre, coordinating and planning postoperative services and obtaining surgical consent to name a few. Guidelines and protocols necessarily feature prominently in preadmission clinics. Each hospital will have its locally specific guidelines. My Department has a forty odd page Preadmission Manual that concerns the anaesthetic aspects of preoperative patient evaluation.

Why is preoperative assessment important?

- No unpleasant surprises- this is top of the list because much unhappiness results if the patient's surgery is cancelled or delayed because of an issue that should have been identified and managed appropriately preoperatively. This reliably annoys the patient, the anaesthetist, the surgeon and the hospital administration.
- To properly prepare the patient- this entails a risk assessment, the provision of anxiolysis, reassurance and often explanation and gaining 'informed consent'. This all takes time.
- Ability to formulate a plan. The anaesthetist requires preparation just like the patient. My Department has an in-house anaesthetic alert database in which we give a 'heads up' to our colleagues regarding upcoming cases that will not be straight forward. Common issues noted are: patient is morbidly obese, patient has a difficult airway, patient has significant co-morbidities, patient had a problem in the past and patient has all of the above.

- Less likely to kill or harm the patient. There is some data from perioperative mortality reports and analyses and expert opinion to support this assertion.
- This is core work for our professional practice, we *are* the perioperative physician. To borrow from the ANZCA Curriculum handbook, it is one of the clinical fundamental roles of the anaesthetist.
- You can bill for it- important in both the public and private arena.

A proforma for preoperative assessment

Components of the Preoperative Assessment:

- Evaluation
 - History
 - Examination
 - Investigations
- Risk assessment
- (Optimization)
- Planning

We will consider each element. The bulk of the evaluation like most of medicine comes from the history. Most people use a proforma of sorts so I will burden you with mine. A crucially important point is that it is essential to document your assessment *legibly*. As an absolute minimum you must print your name clearly so the attending anaesthetist can at least identify who did the assessment and hunt you down for a translation. Of course the entire assessment process must be conducted with the utmost professionalism. This is not enhanced if you are dishevelled and seeing the patient in your crumpled scrubs. Greet the patient warmly and invite them (and their partner/ carer/ guardian) into the consulting room.

After they are seated I say, “Hello my name is Lachlan, I’m one of the anaesthetic doctors. We’re going to sort through some paperwork to make sure you have your operation done safely.” I don’t say I’m an anaesthetist because patients can’t pronounce it and many of them don’t appreciate we are doctors so I tell them so. I mention paperwork because there is a lot of it and the patient can expect lots of ruffling through reams of it and anticipate this consult will take more than five minutes. I often ask patients what they like to be called because the name their parents gave them is often not satisfactory. If you spend the entire consultation calling them something unfamiliar it erodes the patient-doctor relationship. Make an effort to speak clearly (and loudly to elderly patients).

History

I then extract the following information at a minimum. Often the nurse has already done most of the work for you.

- Demographics- patient’s name, age, what operation are they are having, which surgeon is doing it and when. “Is this correct?”
- Drug allergies/ adverse drug reactions- document these even though most of them are complete nonsense. Don’t encourage the nurses by documenting ‘allergies’ to fruits, flyspray, bees and the like. Seafood allergy is not clinically important. Pursue more details if the patient says they had an ‘anaphylactic’ reaction. They usually didn’t. If they have a

penicillin allergy ask if they have had other types of antibiotics eg. 'kefzol or keflex' in the past without issues.

- Medications- do not simply replicate a long list of medications, this is futile. Instead look at it and note the 'important' medications that they take regularly eg. Analgesics, cardiac meds, steroids, insulin, anticoagulants and get the doses right. If you don't know what a medication is- look it up. I have iMIMS on my ipad for this express purpose.
- Previous Anaesthetics- have they had previous surgeries and were there any problems with the anaesthetics for these? The nature of the surgery may suggest whether they were intubated or not or likely to have had a neuraxial anaesthetic. A startling number of patients don't know whether someone stuck a needle in their back or not. If they report a major problem then obviously this needs to be pursued further. *The single best resource in this respect is past anaesthetic records.* We are very fortunate in Queensland in that apart from a couple of notable exceptions every anaesthetic performed in a public hospital since 2010 is able to be accessed from a central database. Failing this look in the chart to see if there are any purple edged pages which is what all the perioperative paperwork is adorned with.
- Family History- if they haven't had a previous anaesthetic which is rare for an adult but not for a child inquire whether there is a family history of problems with anaesthetics and whether they have siblings. If little Johnny's sister has had the same operation last year it is pretty safe to assume Johnny will be okay.
- Cigarettes- Do they smoke/ have they ever smoked? This is your golden opportunity to tell them to stop- a small percentage will cease smoking forever because you told them to. This is the single biggest contribution you can make to that person's health.
- Alcohol- how much? You are trying to discern whether they are at risk of withdrawal, impaired coagulation and increased anaesthetic requirements.
- Illicit drugs- If they're young and smoke and tattooed there's a very good chance they do a bit of something as well. Patients will happily tell you if you ask. This is a marker of their Hepatitis C status.
- Past Medical History- Don't regress to medical student days and ask a huge list of questions. The nurse has already done this anyway. My standard for the middle aged patient is: "Have you ever had a heart attack or a stroke or a blood clot? Do you have diabetes, epilepsy or asthma? Has anything brought you into hospital in the last year?" Any positive responses will lead to more detailed questioning.
- Exercise Tolerance- This is crude but better than nothing. Cardiopulmonary exercise testing is the definitive way to objectively assess this. You are trying to differentiate the okay patient from the one with poor functional capacity. The threshold is the magic 4 METS at which you can climb a flight of stairs without having to stop because of dyspnoea or can walk a kilometre on flat ground. Sex is equivalent to 6 METS apparently but I wouldn't inquire about this! If they stumbled through the door clinging onto a walking stick you can safely assume they have poor functional capacity. If you're not sure take them for a walk up and down a flight of stairs. These are found in most hospitals.
- Further History- Most further history will be informed by responses to the above questions. Don't just document that they've had a CABGx4 two years ago! Before you embark on the examination there are two more things to look at which I term the 'chart palpation'. I look in the surgical outpatient notes to see if the surgeon has written anything

interesting. Not infrequently I can find no evidence that the surgeon has ever laid eyes on the patient- but I digress. Lastly I flick through the correspondence section- a summary from the GP or medical registrar is a pleasant discovery. If you have an electronic record that you can access then now is the time to peruse it. Queensland Health has the *Viewer* which integrates the patient's discharge summary with their pathology and radiology results.

Examination

- General inspection- your examination begins from when you watch them come from the waiting room and walk into the consulting room.
- Vitals- the nurse did them so look at them. Is BP okay, are sats okay? If they are markedly abnormal I repeat the measurement myself. Height, weight and BMI are recorded as a norm.
- Airway- this gets the most attention.
 - General impressions- Is the neck present? Beards are significant- they make bag mask ventilation very difficult at a minimum. Are there any obvious lumps, scars (previous tracheostomy or neck dissection), is their voice normal?
 - Mouth opening- You need at least an inch of mouth opening to be able to cram a LMA in there. Truly restricted mouth opening earns an awake fiberoptic intubation.
 - Mallampati score- ubiquitous in medicine (note spelling) and pretty useless. It should be performed with the patient sitting upright with their mouth wide open and their tongue poking out. It essentially tells you about the size of the tongue relative to everything else.
 - Dentition- this is very important and what you are concentrating on when you are 'assessing' the Mallampati score. Enquire specifically if they have any sore or loose teeth. Do they have any dentures, caps or crowns? Is there anything that can be removed? Document positive findings carefully. Dentures are your friend.
 - Thyromental distance- the distance from the inferior border of the mandible to the thyroid cartilage prominence ('Adam's apple') is usually 'measured' by placing your fingers in the gap. I recommend you measure the distance across your three middle fingers. Less than 6cm is a definite worry, more than 7cm is okay. If you can comfortably fit all four fingers in the gap then you should be spanning more than 7cm.
 - Jaw protrusion- can they grab their top lip with their bottom teeth? I personally don't do this but others enjoy making their patients perform facial contortions.
 - Cervical spine- Do they have problems with their neck? Assess active range of movement particularly flexion and extension. Atlantoaxial extension needs to be assessed by them sitting back against the wall and looking up. Patients with stiff necks are good at disguising it by moving their back to accommodate.
 - In isolation, all these signs have poor specificity and sensitivity in terms of predicting difficulty with airway management. Some are better indicators of difficulty with bag mask ventilation as opposed to intubation and vice versa. See *Difficult Airway 101* for more about this. A combination of positive findings more

reliably suggests there will be problems. Having said that, I ascribe a lot of respect to the patient with a reduced thyromental distance. I expect them to be a difficult intubation and my suspicions are often confirmed. Remember that past anaesthetic records are the best 'test'.

- Cardiovascular system-
 - Feel their pulse- are they in AF or not? Do they need an ECG?
 - Veins- while you're feeling the pulse look to see if there are any visible veins on the back of their hand. If you can't see a thing your colleague is unlikely to find any on the day either.
 - Heart Sounds- if you can hear a murmur with the nurse stethoscope and they are having a major operation then they need an echocardiogram unless they have already had one recently. Cardiologists can't accurately diagnose valve lesions on clinical grounds so don't expect that you will be able to. Patients with severe aortic stenosis can be completely asymptomatic.
 - Look at the ankles for peripheral oedema if they have a history of CCF.
- Respiratory system-
 - What are their sats again?
 - What is their respiratory rate? This is the forgotten clinical sign. If the patient is tachypnoeic or dyspnoeic at rest then they are a poor candidate for anaesthesia.
 - Auscultate in both axillae and all over the back. Convince yourself whether you can hear air entry all over. Are there any added sounds?
- Anything else? There are two more components of the examination to consider:
 - Surgical site- how big is that hernia, where is the skin lesion to be excised? Now is a good time to discover whether the lump has gone away or is so small the patient can't find it. The location of a lump may have implications for positioning your patient.
 - The back- if you are considering neuraxial anaesthesia you should look directly at the back for scars, skin changes, scoliosis and stigmata of underlying conditions (eg. a tuft of hair may suggest spina bifida occulta). Are there any palpable landmarks?

Investigations

These are generally excessively requested by junior doctors because of the fear of missing something or because they think they are doing their boss a favour. I don't care what the serum rhubarb is and neither should you. Consider this startling fact: *there is no such thing as a routine investigation*. There is a purpose to every test you request and if there isn't one you shouldn't request it. Also be cognizant of the fact that if you order a test you are responsible for it in terms of follow up. If you order a Chem 20 (aka SMAC, E/LFTs, MBA, all the same thing) on everyone you are giving yourself ample opportunity to find a host of abnormalities that would have been best left undiscovered. Mildly abnormal LFTs is the classic example and are relatively common. Morbidity and mortality is associated with the pursuit of abnormal test results not to mention incurring delays to surgery. There is no evidence base for ordering tests on people just because they are having a general anaesthetic or they are fifty or they smoke too much. This includes ECGs. Also consider the fact that the majority of patients presenting for major surgery

have already had a battery of tests by the surgeon and the GP. It is pretty unusual for someone to present for a thyroidectomy and they haven't already had TFTs, FBE, U&Es, ultrasound and fine needle aspirate of their lump. Often the ENT guys have already done a cord check and ordered a CT neck for good measure.

Let's consider the most common investigations and attempt to justify situations in which you might request them. For each investigation I consider three factors: is this test necessary because of the nature of the surgery, is this test necessary because of the patient's co-morbidities and the result may alter my anaesthetic plan and lastly, have they already had it done?

Full blood examination (FBE)- everyone over fifty if having major surgery because want to know if they're anaemic; all adult women as they are more likely to be anaemic especially if premenopausal. Order this if you want to know a patient's platelet count.

Chem 7 (U&E's)- patients over fifty undergoing major surgery as want to know if they have renal impairment. Patients with known kidney disease or on medication that can cause electrolyte disturbance.

Chem 20 (E/LFTs)- Patient with known or suspected liver disease (heavy alcohol consumption) or on medication likely to cause liver dyscrasia. Patients booked for cholecystectomy because the surgeons want to know if they have an obstructive picture.

Group and Hold- undoubtedly this is the single most important investigation that is also the most commonly forgotten. This should be requested for any operation with the potential for major blood loss. This is defined as blood loss of half a litre or more- it's always more than this. Common operations that need a group and hold include lap chole, hysterectomy, laparotomy, Caesarean section, TURP, joint arthroplasty, thyroidectomy and fractured neck of femur. The purpose of a group and hold is to detect the presence or not of antibodies. If there are antibodies present then finding compatible blood for transfusion may be difficult. A patient history of transfusion is significant because this patient group are far more likely to have antibodies. The other patient group of note is the pregnant patient. Most labs will consider a group and hold valid for 14 days from when it was taken for non pregnant subjects and only a week if they are pregnant. If they have been transfused recently it needs to be repeated. A group and hold takes about forty minutes to perform so it is not appropriate to order this test 'on the day' because it takes time to do and if they find an antibody they may not have compatible blood available. If you have started the procedure and the blood-letting is in full flow then you are in a self-inflicted world of pain.

Crossmatch- be aware that most labs don't do a crossmatch as such. They do a group and hold, also called type and screen, and simply issue appropriate blood in the event that you want to transfuse. They will usually only do a formal crossmatch for the patient with antibodies or if they have been recently transfused.

Coagulation Studies- patient on warfarin and patient with known cirrhosis. Patients with a family history or personal history of a bleeding disorder should be referred to the haematologist. Von Willebrands disease is the commonest inherited bleeding disorder and a routine coagulation screen will be completely normal. Most coags that are ordered are unnecessary. Advanced age, renal impairment and planned major surgery are not indications for coagulation studies.

ECG- patient over fifty undergoing major surgery so you have a baseline when they flip their t waves perioperatively. Patients with known cardiovascular disease especially dysrhythmias.

Chest X-Ray- I don't order these in any circumstances unless I think they've got a huge pleural effusion that no one else seems to have noticed.

Spirometry- I don't order as it doesn't change my management. Patients with bad COPD are readily identified and the fact that their FEV₁ is a litre doesn't preclude them from having a bowel resection. (They won't do well of course.)

ABG- very much underutilized and quick and simple to perform. If their sats are below the nineties and you are worried about them then you should do a gas. If their PaCO₂ is in the forties they will not do well. If their PaCO₂ is higher than their PaO₂ they should not be having surgery.

Serum drug levels- I don't order these as I don't manage them in the long term.

Pregnancy test- urinary hCG is appropriate for women of child bearing potential and generally done by the nurses on the day.

Echocardiogram- if they have a murmur or terrible dyspnoea or terrible exercise tolerance and they are to undergo major surgery. If they don't have a murmur and have reliably good exercise tolerance then it is a waste of time.

Brain Natriuretic Peptide (BNP)- simple test to consider in the patient with dyspnoea and you are not sure if the heart or lungs are the problem. If the BNP is significantly elevated (>300) then the heart is the problem and they are suffering significant cardiac failure. Then they need an echo and a cardiology consult.

Other cardiac investigations- I let the cardiologists order them, interpret them and manage them. There are few things more useless than an equivocal myocardial perfusion scan. A negative exercise stress test is reassuring. Requesting a cardiology referral means you are prepared to delay their surgery for weeks to months.

A few examples

Elderly patient for a bowel resection who's had recent bloods ordered by the surgical resident- look up the bloods and you'll note there's no Group & Hold so order this as well as an ECG. Don't order coags.

LSCS- need a FBE and a Group and Hold within a week of the intended date of delivery.

Healthy forty-five year old man having an inguinal hernia repair- does not require any investigations.

Medication Management

This is simple. The patient should take all of their normal medications on the day of surgery with the following exceptions:

- Oral hypoglycaemics and short acting Insulins should be withheld because of the risk of hypoglycaemia (see below).
- Heparins are withheld because of the risk of bleeding.
- Oral anticoagulants and anti-platelet agents are generally withheld for all but the most minor forms of surface surgery. See *Antithrombotic Drug Management* for more details.
- Many anaesthetists will withhold ACE inhibitors and Angiotensin Receptor Antagonists on the day of surgery because of the risk of hypotension.

- Herbal medications should generally be stopped a week prior as many have a weak anti-platelet effect.

Everything else should be taken and preferably at around the normal time that they would take their medications. Generally speaking low dose aspirin therapy can and should be continued throughout the perioperative period. See *Studies you should probably know about* for more details. It is very important to ensure patients have taken their chronic steroid therapy and analgesic agents. Supplemental steroid therapy is almost never required and the frequent use of dexamethasone as an antiemetic probably negates ever having to reach for an amp of hydrocortisone with the possible exception of the patient who has a lack of endogenous corticosteroid.

Management of diabetics- True type 1 (insulin deficient) diabetics are rare and are best managed with an insulin and dextrose-saline infusion. For the rest the aim is normoglycaemia-hypoglycaemia is dangerous and hyperglycaemia is associated with an increased risk of surgical site infections and adverse cardiac events. All oral hypoglycaemic drugs should be withheld on the day of surgery including Metformin. Short acting insulins should be withheld. Most diabetics on insulin are taking Lantus (glargine insulin)- if they normally take their Lantus in the morning then they should take a reduced dose, about half their normal dose. If they take it at night they have that as per usual. Patients on intermediate acting insulins (Protophane) should take a reduced dose in the morning if they normally take it then.

Routine Planning

Am I prepared to do this case? - An important consideration for the GP anaesthetist or remote practitioner is whether you are actually happy to do the case at all. This decision is informed by your skill which requires insight and the capabilities of the hospital and perioperative team. Common reasons to say no are that the patient is too fat, too young, too sick, has a known anaesthetic problem in the past or your gut instinct says no. There is nothing to be gained by being a hero.

Premedication- infrequently requested for adults but common ones are oral dose paracetamol or NSAID. Ranitidine 150mg x 2 doses for pregnant patients and those with reflux. For paediatric patients we have a standing order of 20mg/kg paracetamol and topical local anaesthetic cream. EMLA needs to be properly applied under an occlusive dressing for an hour to work. I often tell the child to tell the nurse where I want the EMLA applied.

Fasting- two hours for water and dedicated preoperative carbohydrate drinks and six hours for everything else including cigarettes. I don't limit how much water people can have. Generally people are starved and dehydrated to an excessive extent. You feel a whole lot better if you have a decent drink of water at 6am as opposed to ingesting nothing since dinner the previous evening. Chewing gum is not a concern for me but I don't encourage it.

Medication management- as above and most importantly give your patient written instructions if the advice is anything other than 'take everything as per usual'.

Proposed anaesthetic plan- intended mode of anaesthesia or options available discussed at a minimum. See next section for more details.

Pain management- if you are considering a PCA or epidural or nerve block then you should discuss this with the patient.

Postoperative Management- will they need to stay overnight? Do you need to book an ICU bed? It is a lot easier to cancel it than try and get it on the day!

Consent- Many anaesthetists use a written consent form. My hospital's generic consent to anaesthesia form is reproduced below. If there are any particular risks you or the patient are concerned about then these need to be discussed and some form of documentation completed to reflect that this discussion occurred. A dedicated form signed by you and the patient is the best option. Conversely there is nothing to be gained by showing a consent form in front of the patient who is about to be taken into theatre. At a minimum you should specifically ask the patient if they have any questions about the anaesthetic and do your best to answer them. The discussion about risks of anaesthesia later in this chapter informs the process of obtaining consent.

Documentation- Have you completed the anaesthetic assessment and printed your name on it? Can you read it? Does the patient warrant an alert? My Department has an in-house 'Anaesthetic Alert' database that generates a report about patients scheduled to have surgery in the forthcoming week who are complex. This essentially gives the anaesthetist actually doing the case a 'heads up' and facilitates appropriate planning. Lastly have you documented the ASA status? The American Society of Anesthesiologists classification of physical status is possibly the only item of perioperative data that is universally collected. Although never intended as a risk stratification tool it still functions pretty well in this role. Be aware that there is no manual or definitive reference that tells you how to designate an individual ASA score. In recent years the ASA released a document with some examples on it. I don't find the document useful. You have to exercise common sense. As an aside anyone having ECT or a joint replacement must be an ASA 3 at least because they have a systemic illness that is causing functional impairment.



Queensland Government

Anaesthetic Record

(Affix identification label here)

URN:

Family name:

Given names:

Address:

Date of birth:

Sex: M F I

Facility:

Operation:

Operation Date:

Assessed by:

Surgeon:

Weight:

Height:

HR:

BP:

SpO₂:

BMI:

History:

Allergies:

Medications:

Results:

Airway assessment:

Anaesthetic options discussed:

HDU bed booked:

Premedication ordered (refer to Medication Chart)

Signature:

Date: / /

ASA

DO NOT WRITE IN THIS BINDING MARGIN
Do not reproduce by photocopying.
All clinical form creation and amendments must be conducted through Health Information Services.

v11.00 - 05/2015
Mat. No.: 10125989



00104-54zmb

Anaesthetic Record



TOOWOOMBA AND
DARLING DOWNS
HEALTH SERVICE DISTRICT

Consent to Anaesthesia

UR No: _____

Surname: _____

Given Names: _____

Address: _____

DOB: _____ Sex: _____

(Please affix patient identification label here)

For you to give consent to anaesthesia, it is required that you are informed of the associated risks. Many of these risks are unpredictable, and potentially apply to everyone undergoing anaesthesia. Pre-existing medical conditions and the nature of the surgery may increase some of these risks.

TYPES OF ANAESTHESIA

- **General anaesthesia**
Most people understand this as being asleep during surgery. Drugs are given to produce a state of unconsciousness.
- **Regional anaesthesia**
This is the use of a nerve block to numb the part of the body to be operated on. Nerves to the arms, neck, chest, abdomen, legs and eyes can all be blocked.
Spinal and epidural anaesthetics are examples. Injections into the back are used to numb nerves to the chest, abdomen or legs.
- **Sedation**
Monitored sedation varies from mild drowsiness to a form of light general anaesthesia. You may remember parts of procedures carried out under sedation, and this is not abnormal.

RISKS

All forms of anaesthesia (includes general and regional anaesthesia)

The risk of life threatening complications is quite small. Death as a result of anaesthesia itself (i.e. unrelated to the surgical procedure) is about one in 20,000.

Such complications not severe enough to cause death may result in permanent damage to major body parts including brain e.g. stroke, heart e.g. heart attack, liver, kidneys, lungs, spinal cord e.g. paralysis – paraplegia or quadriplegia i.e. inability to feel or use legs and/or arms, and blood vessels.

Far less serious but more common problems of all forms of anaesthesia are:

- bruising, pain or some injury at the site of injections, including intravenous cannula sites i.e. drips
- nausea and vomiting

Cigarette smoking potentially increases the risks associated with anaesthesia. To minimise these risks you should stop smoking as long as possible before the operation.

General anaesthesia and sedation

1. Common problems

- sore throat
- hoarse voice (usually short lived and temporary, rarely permanent)
- fatigue, sleep disturbances
- dry eyes
- muscle pains

2. Uncommon problems

- post-operative breathing and respiratory difficulties
- damage to lips and tongue, eyes, teeth or dental work (e.g. caps)
- aggravation of epilepsy
- peripheral nerve damage (e.g. damage to nerves in arms, legs, face)
- awareness (i.e. being awake while under general anaesthetic)

DO NOT WRITE IN THIS BINDING MARGIN

v4 01/04/2007

Consent to Anaesthesia

MR 56p(T)

Name:	DOB:	UR:
<p>Regional anaesthesia</p> <p>1. Nerve damage (applies to all nerve blocks including spinal and epidural anaesthetics)</p> <ul style="list-style-type: none"> ▪ uncommon incidence of between one in 5,000 and one in 50,000 ▪ may result in weakness and/or numbness of the body part that the nerve goes to ▪ may be minimal and temporary ▪ rarely severe and permanent (this includes paralysis – paraplegia or quadriplegia) ▪ may be due to direct trauma, bleeding, infection or unknown mechanisms <p>2. Damage to surrounding structures (e.g. blood vessels, lungs)</p> <ul style="list-style-type: none"> ▪ uncommon ▪ depends on site of nerve block, blood vessels, lungs <p>3. Other risks of spinal and epidural anaesthetics</p> <ul style="list-style-type: none"> ▪ headaches <ul style="list-style-type: none"> ➢ may be severe but usually is self-limiting though may last many days ➢ rarely associated with more severe problems ➢ risk varies with procedure – on average risk is 1 – 5% ▪ backache <ul style="list-style-type: none"> ➢ this is usually localised and temporary ➢ rarely it may be chronic 		
<p>It is suggested that you read this document more than once to ensure you fully understand the risks.</p> <p>The above is not meant to scare you, but rather give you information so that you can make an informed decision. Please discuss any of the above with your anaesthetist when he sees you. It should be noted that Australia has one of the lowest death rates associated with anaesthesia in the world.</p> <p>If you may be pregnant you should inform the anaesthetist when he visits you.</p>		
<p>I, _____ have read the above and have asked the anaesthetist about everything I did not understand.</p> <p>Signature: _____ Date: / /</p>		
<p>Please do not sign this until you have been seen by the anaesthetist when you are admitted to hospital</p>		
<p>Name of patient (if different from above): _____</p> <p>Relationship to patient: _____</p> <p>Witnessed by anaesthetist (signature): _____ Date: / /</p> <p>Print name & designation: _____</p>		

DO NOT WRITE IN THIS BINDING MARGIN

Preoperative assessment- the abbreviated version

We are perennially under time pressure and we all skip some components of our normal preoperative assessment when we are in a rush. There are some things you shouldn't skip, however, and this is my abbreviated assessment borne out of experience from working countless emergency boards.

- **Patient identification-** if you put someone to sleep and you're not sure who they are this is a bit of a disaster. If the patient can't tell you then you need a handover from someone who is sure of the patient's identity.
- **Allergies-** even when they're invariably all nonsense. If they say a drug that you were intending to use then ask specifically about the nature of the reaction to the drug.
- **"Have you had an anaesthetic before and were there any problems?"**- hopefully this is when they tell you they've got Scoline apnoea or whatever.
- **"Do you have any major medical problems?"**- often people trot out their little list in this event (Mine is- Have you ever had a heart attack or a stroke. Do you have asthma, diabetes, epilepsy, any heart problems, anything brought you into hospital in the last year?)
- **"Do you smoke?"** aka "Will you be coughing and spluttering when I come to extubating you?"
- **"Do you have any questions for me?"** Usually they don't.
- **Perform an airway assessment-** partial plate or not, does this look straight forward or not, do they have an enormous hair bun (latter is invariably missed on the stat CS patient where it contributes to an even more challenging laryngoscopy).
- **Feel pulse, look at patient, auscultate praecordium and axillae.** Are they in AF, do they look sick, do they have a rip roaring murmur or chest signs?
- **Does the drip work?** You must be able to directly visualize the cannula.
- If patient looks sick/ are on oxygen/ have a spew bag beside them- think twice before embarking on the case. It takes about a minute to do all of the above. You always have a minute.

Don't start a case without an anaesthetic assistant. You will regret it.

Risks of Anaesthesia

This is a huge topic. Large tomes could and have been written about this subject. I am going to give you a very truncated version. This is a topic that is very poorly understood by surgeons, patients and junior doctors. Observe an intern getting surgical consent for a procedure from a patient and you will hear something like this: "The risks of the procedure include those from the anaesthetic- you could die, you could have a heart attack or a stroke..." This is pretty unlikely if you are having your toenail removed and reflects a discussion about risk that is both uninformed and unrewarding. The most frustrating aspect of course is that there is very little we can do about the risks of a procedure. More about this later.

Anaesthesia itself is incredibly safe. But unless you are Michael Jackson you don't come to theatre just to be put to sleep. (I should point out that it was a cardiologist who administered propofol to an unmonitored Jackson!) The risks of surgery and anaesthesia are inextricably linked and it is an artifice to separate them. In Australasia having surgery is still very safe and we take pride in the claim that we have the safest practice in the world. For the majority of healthy

people undergoing elective surgery we rightly expect a very low incidence of adverse outcomes. The most recent ANZCA triennial anaesthetic mortality report quotes the incidence of death purely or partially attributable to anaesthesia to be roughly one in sixty thousand anaesthetics. The annual risk of dying in a motor vehicle accident in Australia is about one in twenty thousand. I often tell patients, quite legitimately, that the most dangerous thing they will do when they have their surgery is drive to and from the hospital. Doctors are poor at expressing risk in meaningful terms. Just quoting a number is suboptimal. Patients will often accept horrible risks because of a variety of reasons: they don't understand what they're hearing, they think they must have the operation so must accept the risks or they prefer not to know in the misguided belief that 'they will be okay'. Ignorance is bliss most of the time. I would consider a quoted risk of death of 1% for myself as intolerable yet the average punter doesn't give this a second thought.

Before I scare you with some real world perioperative risks it is useful to consider risks that are reasonably exclusively associated with the anaesthetic itself. I have already acknowledged this is an artificial exercise but we can reasonably 'blame' ourselves for the risks described below.

Risks attributable to anaesthesia itself

Dental damage- we put large hunks of metal in people's mouths so not surprisingly sometimes we chip a tooth or bruise a lip. Dental damage is the leading cause of litigation against Australian anaesthetists. If the dentition is loose or in poor condition or artificial it is more likely to be damaged.

Minor but obvious- Bruising from IV cannulation(s), corneal abrasion, sore throat.

PONV- baseline risk of 10% for all procedures and goes up from there. We are unlikely to ever eliminate this adverse outcome of anaesthesia.

Awareness- not all awareness is due to anaesthetic error but I would suggest the majority is attributable to the anaesthetist! Most textbooks quote an incidence across the board of 2 per 1000 anaesthetics. The recent NAP5 UK audit of the incidence of awareness which is probably the best real world data we have reported a much lower incidence of one in 19,000.

Death- hard to quote an accurate figure but it is certainly less than about one in a hundred thousand. These are mostly accounted for by hypoxia due to lost airway, aspiration and anaphylaxis. Aspiration is arguably the single greatest cause of death that is directly attributable to the anaesthetist.

The sobering truth about perioperative risk- the REASON study

Most of us will have our operation uneventfully. It is relatively easy to identify patients who are subject to higher risks than the average. ASA 4 is a good starting point! Probably the most readily identifiable and studied patient group are the elderly, namely patients aged seventy and over. The REASON study was an observational study that looked at outcomes after surgery in the elderly cohort. The data collection and validation of outcomes was conducted very well. They collected data from over twenty hospitals in Australia and New Zealand in 2007-2008. The enrolment criteria were very simple- all patients aged seventy or more who were having non-cardiac surgery that required at least an overnight stay. This includes emergency and elective surgery and even some procedures that didn't require anaesthetic services. Over four thousand patients were enrolled. The results were very sobering and represent our best real

world data on the risks of surgery in Australasia: at 30 days postoperatively, 1 in 20 patients were dead and 1 in 5 had a major complication. So your ‘well’ seventy-five year old patient presenting for a total knee replacement has a predicted baseline mortality of five percent! Your sick eighty year old for the emergency laparotomy who has diabetes and ischaemic heart disease has more like a twenty percent chance of being in a pine box a month down the track. Having surgery is risky business if you are elderly with co-morbidities. Of the preoperative factors associated with mortality in the REASON study, ASA 4 status had the highest odds ratio by a large margin.

We have developed tools that are quite good in terms of being able to quantify risk. There are detailed online perioperative risk calculators of which the American ACS NSQIP surgical risk calculator is probably the most impressive. There are a host of cardiac risk calculators and indexes of which Lee’s Revised Cardiac Risk Index (RCRI) is the best known and has been validated in large data series. Mercifully the RCRI is relatively simple and has six independent predictors, each with the same weighting. They are: intrathoracic, intraperitoneal or infrainguinal vascular surgery; history of ischaemic heart disease; history of congestive cardiac failure; insulin treatment for diabetes; serum creatinine level > 180umol/L and history of cerebrovascular disease.

The predicted incidence of a major adverse cardiac event is illustrated in the table below.

Number of predictors	Risk of major cardiac complications
none	0.4%
one	0.9%
two	7%
Three or more	11%

Data from T Lee et al. Derivation and prospective validation of a simple index for prediction of cardiac risk of major noncardiac surgery. *Circulation* 1999; 100: 1043-9.

Perioperative stroke is a catastrophic event for both the patient and their family. The POISE trial which was the largest perioperative medicine trial at the time reported an across the cohort incidence of stroke for at risk patients undergoing surgery of just under one percent. Generating a number doesn’t make anything better, though. At best it may give you ammunition to help convince the patient not to have the procedure. Patients very rarely choose not to have an operation because of a quoted perioperative mortality rate. They are convinced they need to have the operation.

Risk management options

Despite conducting massive perioperative medicine trials in recent years (See *Studies you should probably know about*) we have not identified (and probably never will) a specific pharmacological intervention that decreases perioperative risk. There is no silver bullet.

Available strategies to manage risk include:

- ‘Optimizing’ patient condition- if there is something that can be improved then it makes sense to do this, eg. Untreated hypertension, active bronchospasm, uncompensated cardiac failure. Unfortunately most of our patients have end-stage, unimprovable disease.

- Altering the nature or extent of surgery; the timing of surgery; the location of surgery or the postoperative environment.
- Choose your surgeon- I think this is the main benefit of private medical insurance. ‘Better a good surgeon and an average anaesthetist than a good anaesthetist and an average surgeon.’ In America surgeons’ complication rates are publically available. It is not disputed that if your surgery is done by the best surgeon you will get better results. Experience counts.
- Don’t have the operation. Sometimes this may not be an option but often it is one the patient has not considered. Their incisional hernia is unlikely to kill them unlike the operation to repair it. *The only way to avoid the risks of an operation is not to have it.* This is the great truth of perioperative medicine.

Note I did not mention a particular anaesthetic technique or mode of anaesthesia or drug because there is precious little evidence to say that these change outcomes.

SELECTED REFERENCES

Safety of Anaesthesia. A review of anaesthesia-related mortality reporting in Australia and New Zealand 2009-2011. Edited by Larry McNicol.

5th National Audit Project (NAP5) on accidental awareness during general anaesthesia: summary of main findings and risk factors. J Pandit et al. *British Journal of Anaesthesia* 2014; 113: 549-59.

Complications and mortality in older surgical patients in Australia and New Zealand (the REASON study): a multicentre, prospective observational study. D Story et al, *Anaesthesia* 2010; 65:1022-30.

Postoperative Mortality in Children After 101,885 Anesthetics at a Tertiary Pediatric Hospital. B van der Griend et al. *Anesthesia and Analgesia* 2011; 112: 1440-7.

Probably the best figures we have available for paediatric mortality in this country. This was an audit of all cases done between 2003 and 2008 at the Royal Children’s Hospital in Melbourne. There were ten cases of death that were considered to be anaesthesia related. This is an incidence of 1 per 10,000 anaesthetics. Of note, all the cases had major cardio respiratory co-morbidities, especially pulmonary hypertension.

CHALLENGE QUESTIONS

1. A biochemical profile comes back with the following abnormalities. What is the likely diagnosis? (Reference range in brackets.)
Na 132 (135-145)
K 3.2 (3.5-5.2)
Urea 1.5 (2.5-6.8)
Cr 42 (64-108)
Alb 26 (35-50)
ALP 220 (30-110)
2. What about this one? The patient is healthy.
Na 133 (135-145)
K 6.1 (3.5-5.2)
Urea 6.5 (2.5-6.8)
Cr 82 (64-108)
Phos 1.9 (0.75-1.5)
ALT 55 (<45)
AST 53 (<35)
LDH 476 (120-250)
3. A mother presents with her four year old child who is booked for tonsillectomy. The mother says her brother is MH susceptible. The child's mother has never had an anaesthetic. What are the chances that her child is MH susceptible? How could you definitively determine the child's status?
4. What nerve is most commonly damaged during anaesthesia?
5. What tooth is most commonly damaged by the anaesthetist?
6. An amp of hydrocortisone is equivalent to how many milligrams of prednisone?
7. How much renal function does an eighty year old have compared to a thirty year old?

ANSWERS

1. This is consistent with pregnancy. The reference range is for non-pregnant patients.
2. This is consistent with specimen haemolysis. Usually the lab tells you this because they want you to collect another specimen.
3. MH is most commonly inherited in an autosomal dominant fashion. This means the mother has a fifty percent chance of carrying the gene presuming her brother inherited it from one of their parents. It is possible but less likely that it was a spontaneous mutation. Her children have a fifty percent chance of being MH susceptible if she is. The only way to definitively determine the child's status is for her to have CHCT (Caffeine Halothane Contracture Test) testing on a muscle biopsy. Unfortunately the testing centres don't offer CHCT tests on children less than ten years of age. The mother could have the test, though. Genetic testing is less reliable and may not be an option. In practice you would give this child a non-triggering anaesthetic which is no simple task. The mother should be encouraged to be tested.
4. The ulnar nerve is the most commonly 'damaged' nerve in the perioperative period. Neuropraxias relating to pressure on the nerve are the most common manifestation and these normally resolve. Unfortunately despite taking the best standard of care in terms of precautions, ulnar nerve damage can still result. Many patients who present with an ulnar nerve injury postoperatively have an underlying neuropathy that is often not identified preoperatively.
5. The upper left incisor is most commonly damaged. This is where your laryngoscope tends to lever against the upper teeth if you aren't careful. Dental damage is still the leading cause of litigation against Australian anaesthetists.
6. 100mg of hydrocortisone is equivalent to 25mg of prednisone and 4mg of dexamethasone. Dexamethasone has no mineralocorticoid activity.
7. An eighty year old has less than half the renal function of a young adult. Glomerular filtration is reduced by one percent per year beyond the age of thirty. Importantly, this renal 'impairment' is not reflected biochemically.

LIGHT RELIEF

WHAT WORRIES ANAESTHETISTS? (Other than the difficult airway)

- Beards and bad teeth
- A full set of immaculate capped teeth
- Patient's whose BMI exceeds their EF
- Stridor at rest
- Ischaemic sounding chest pain
- Tattoos and IVDU
- Jehovah Witnesses involved in road trauma
- Subpoenas
- Ejection systolic murmurs that you can hear with the nurse's stethoscope
- When the surgeon asks you if the patient has been cross-matched
- Funny looking ECGs
- Urgent C-sections, flat babies and no paediatrician to be seen
- Coagulopathies
- Absence of visible or palpable veins
- The patient on carvedilol
- The chronic pain patient presenting for surgery
- An obscure history of "some sort of problem with the last anaesthetic and they said I really scared them"
- Clexane, Clopidogrel and Coumarin
- Neonates
- Ankylosing Spondylitis
- Automatic Implantable Cardioverter Defibrillators
- When the CVP is rising up to meet the falling MAP
- Asystole
- ANY COMBINATION OF THE ABOVE

Planning the Anaesthetic

Start with a good plan

As elaborated in the previous section, formulating an anaesthetic plan is a component of the preoperative assessment. In public practice the formal assessment is often done by someone other than the person actually anaesthetizing the patient. Planning the anaesthetic is generally pretty straight forward. However if you enact a poor plan then your task can become needlessly unpleasant. Considered simply the choices you need to make are:

- Mode of anaesthesia- GA vs sedation vs LA vs regional vs combination.
- If GA- LMA or ETT. If ETT, which muscle relaxant to use?
- What analgesic and antiemetic agents will I use?
- How will I maintain anaesthesia?
- Finally and most importantly- Do I think any of the above elements are going to be difficult? Securing the airway tends to dominate this consideration. Difficult airway management is considered in detail in *Difficult Airway 101*.
-

The factors that will influence the above decisions are surgery and anaesthetist specific and to a lesser extent patient specific. Some people favour the PEAS acronym- Patient factors, Equipment factors, Anaesthetic factors and Surgical factors. Once you have made your plan you need to communicate this to your anaesthetic assistant. They will want to know what airway device to prepare and which drugs to get out of the DD cupboard. If you anticipate some difficulty with the anaesthetic and haven't given your anaesthetic assistant a heads up then you have yourself to blame when they don't magically hand you your favourite rescue airway device or whatever when things start to unravel.

Mode of Anaesthesia

LA only- although great for us ("I'll be in the tearoom..."), this mode requires an elusive triad of conditions to be satisfied: patient is happy, the surgeon is happy and the actual procedure is amenable to being performed under a field block.

Sedation- in itself, sedation is only adequate if the procedure is not painful which most are so invariably some analgesic is also administered. Although 'sedation' is what is provided for endoscopies you should be aware that the majority of anaesthetist provided sedation for endoscopy is general anaesthesia: the patient is unconscious and unresponsive courtesy of white stuff. Sedation is not an appropriate rescue for inadequate local anaesthesia, general anaesthesia is. Sedation is often requested by the surgeon to make *them* more comfortable when it is the patient's comfort that should be the priority.

Regional anaesthesia- Neuraxial blockade, most commonly with a spinal, is excellent for any procedure below the umbilicus expected to take an hour of surgical time. Peripheral nerve or plexus blockade is rarely sufficient as the sole mode of anaesthesia for a procedure especially if a tourniquet is used- which is most of the time. It needs to be a good block! Every time you stick a needle in the back or neck or groin you need to think about what you'll do if it fails. Providing general anaesthesia is the default rescue.

Airway Device

The majority of anaesthetics given in Australasia are a GA with a LMA. This has a formidable track record in terms of safety and efficacy. This is taken to the extreme in a centre like Cairns where the Proseal is so ubiquitous that they nominate a month each year where they elect to intubate people! Although a LMA can and has been used for pretty much everything I don't condone this as routine practice especially for a trainee anaesthetist. There are few absolute indications for intubation but what follows is a relatively conservative set for the junior anaesthetist in a public hospital.

The following patients should be intubated:

- Those at risk of aspiration- see Case 4 at the end of this section for a detailed list of these. This does not include patients with 'reflux'.
- Intra-abdominal procedures where muscle relaxation is necessary to facilitate surgery. Many simple abdominal procedures don't require paralysis- open inguinal hernia repair for example.
- Procedures expected to take more than an hour or so- there's a very good chance it will take two or three. You'll feel happier with a gold standard airway in situ when everything else starts to go awry.
- Procedures where airway security is paramount-
 - Difficult airway
 - Head and Neck surgery
 - Pt in prone position
 - Infants
- To facilitate mechanical ventilation- neuroanaesthesia, going to ICU postoperatively.
- Failure with LMA- this is rare (suboptimal placement is not).

Everyone else gets a LMA. The choice then is which type of LMA? A flexible LMA (also called 'reinforced' as there is a metal spiral in the tube) is often used for head and neck, dental and maxillofacial surgery to enable surgical access without the airway tube getting in the way. There is little hard data to favour second over first generation LMAs although undoubtedly the former dominate the market in Australia. My interpretation of what constitutes a second generation device is one which has a separate airway tube and gastric port. There is no published clinical evidence to suggest second generation LMAs are safer than first generation devices in terms of aspiration risk. Intuitively it would seem reasonable to expect that a well placed 2nd generation LMA is likely to divert a regurgitant stream of stomach contents up the gastric port and clear of the glottis. Possibly a more valid criteria to favour a 2nd generation device is their superior design in terms of having a higher leak pressure- especially if you work with a patient caseload that is predominantly obese.

Some brief notes about specific models of LMA:

Unique/ Classic- 1st generation can be inserted using the reverse technique which is handy.

Supreme- 2nd generation, quite stiff and easy to scuff the throat, easy to insert but can sit too high in some patients, particularly large men.

Igel- 2nd generation, lacks a cuff so don't need a syringe, softer than a supreme, narrow gastric port, popular in the UK.

Proseal- 2nd generation, lot of published experience with this device courtesy of Joe Brimbacombe, reusable device. Speaking as a patient I would prefer not to have a piece of plastic that had been stuck down forty other people's throats shoved down mine. There are no economic advantages with Proseals as they have a much higher unit price and need to be processed after each use. Autoclaving is expensive business.

Ambu- 1st and 2nd generation models, they both have an accentuated 'anatomical' curve and no bars across the glottic opening, makes a good conduit for a bronchoscope.

Intubating LMA- 1st generation, very rigid, designed for blind passage of a specialized ETT or as a conduit for a bronchoscope. The intubating LMA is becoming the most neglected member of the LMA family courtesy of videolaryngoscopes.

Every anaesthetist should know that the LMA was invented by Archie Brain, a British Anaesthetist, and that he deserved the Nobel Prize for Medicine for his efforts. No anaesthetist has won a Nobel. Sizing of LMAs is determined by bodyweight and is fairly consistent across LMA types and manufacturers.

Bodyweight	Size LMA
<5kg	1
5-10	1 ½
10-20	2
20-30	2 ½
30-50	3
50-70	4
70-100	5
>100	6

In practice women get a 4 and men a 5 unless either of them weighs less than 50kg. I've never seen a size 6. The LMA is a very forgiving device and whatever the tech hands you will probably be fine.

Criteria to guide the selection of muscle relaxants, analgesics and antiemetics are presented in the relevant earlier chapters on these drugs.

We will integrate the components of the anaesthetic plan and consider two of the most common 'recipes' in detail. Behaviours and practices that will be repeated on countless occasions through the course of your working life should be subjected to robust analysis.

The Basic Recipes

The first is a general anaesthetic with a LMA. Induction with (midazolam) fentanyl and white stuff. The second is a general anaesthetic with an endotracheal tube, the same induction drugs and rocuronium as the muscle relaxant. Maintenance of both by smelly and oxygen and air. These are simple, cheap and versatile anaesthetics and account for the majority of anaesthetics given by trainees at present although there is a growing population of TIVA devotees in the trainee cohort. Propofol TCI is discussed in great detail in a separate chapter. Laryngeal masks

and propofol complement each other nicely and it is very fortuitous they were introduced at roughly the same time. (Interestingly the first described technique for LMAs by Dr Brain entailed induction with thiopentone, paralysis and then placement of the LMA!) One can very reliably induce anaesthesia and insert a LMA using propofol alone. Invariably fentanyl and almost as frequently midazolam are given on induction as well. It is a useful exercise to evaluate the role of these two drugs.

Fentanyl provides analgesia which is required for most procedures. It obtunds the airway reflexes and autonomic response to airway manipulation. It reduces MAC and the C_p50 equivalent of propofol in a synergistic fashion. For fentanyl to achieve these pharmacodynamic effects it needs to have reached the effect site and be given in an adequate dose. The time to peak effect for an intravenous bolus dose of fentanyl is about four minutes. The common practice of injecting a single ampoule (100 micrograms) or less ten seconds before the white stuff doesn't enhance the induction nor modify how much white stuff you give. To obtund the pressor response to intubation requires at least 2-4 mcg/kg. Five to eight mcg/kg will reliably ensure minimal response to intubation but will cause prolonged respiratory depression and may cause muscle rigidity and marked bradycardia. The take home message is give the fentanyl well before the white stuff and be prepared to crack open the second ampoule!

The desirable pharmacodynamic effects of midazolam are hypnosis, amnesia and anxiolysis. Propofol does all these as well. The effect site equilibration time for midazolam is variably reported to be between two and seven minutes. It would seem midazolam has limited utility in most anaesthetics if it is given on induction hence the parentheses around it above. It can sting on administration as its formulation has a pH of 3.3 to make it water soluble. Midazolam is undoubtedly an excellent anxiolytic and relatively safe as a sole agent but there is negligible benefit to the patient if administered twenty seconds before the white stuff. If you do give it in a more sensible timeframe it will cause hypoventilation enough for the patient to desaturate on room air and a degree of drowsiness that is not compatible with them wriggling onto the operating table or answering questions appropriately like "What operation are you having?"

Anaesthetic, surgical and patient factors will modify the basic recipes described but it is surprising how infrequently this is done or indeed warranted. Anaesthetic factors are mostly accounted for by practitioner preferences- there's more than one way to anaesthetize the proverbial cat. Level one, outcome based data doesn't feature in the formation of these preferences! This is partly because there is a paucity of quality evidence. Mimicry and anecdote have shaped the majority of practice. Trainees quickly learn how Dr X likes LMA type B, uses opioid C and never uses midazolam whereas Dr Y likes LMA type A, opioid B and always uses midazolam. Then there's Dr Z who likes TIVA with nitrous. Patient factors, namely allergies and co-morbidities, may influence the selection of opioid and muscle relaxant and the choice of airway. Some surgical procedures will have special anaesthetic requirements. These are self evident if you know what the operation entails. I contend you can't plan an anaesthetic if you don't know this vital information. If you don't know what the operation is ask the surgeon or Google it. One particular aspect not well appreciated by surgical and anaesthetic trainees is the consequences of the position the patient will be in for the procedure.

Patient positions other than supine

Laparoscopy/ Lithotomy - Patient will need to be intubated and arm access may be restricted, for example gynaecologists usually want both arms tucked in and for an appendicectomy the left arm is tucked by the side. The patient may be tipped head up (laparoscopic cholecystectomy), head down (gynaecology) or all over the shop (laparoscopic bowel resection). The patient will need to be slid down the bed to be put in position. To avoid disappointment take the head off the operating table and ask which arm you can have access to. If access to both arms is impaired it is handy to use a 'head and neck' IV set with a proximal injecting port that you can get to without compromising the sterile field.

Lateral position- Using a LMA is fine. The arms need to be padded and not hyperextended or excessively flexed. The shoulders shouldn't be abducted or flexed beyond ninety degrees. If a pillow is placed between the arms an arm strap is also usually required to stop the upper arm sliding off. Padding between the legs is in order and side bolsters should be used. For longer procedures don't forget to place an axillary roll. An axillary roll is not placed in the axilla despite the name! It is positioned below the axilla and underneath the upper ribs to prevent pressure on the brachial plexus and vessels. I recommend a litre bag of fluid as they are always at hand and don't slowly deflate during the course of the case like a pressure bag does.

Beach chair- used for upper limb surgery mostly. There should be a low threshold for intubation and an arterial line. Eye protection needs to be good and goggles are suitable for this. The head and neck needs to be in a neutral position and very carefully 'fixed' only when all the other positioning has been sorted eg. patient dragged to the side and top of the bed and then sat up. Similarly the patient's head is the first thing to be released and supported at the end of the case. The legs are padded and often elevated on a wedge, the arm board needs to be able to swivel.

Prone- a position that demands respect and subjects the patient to all sorts of risks and indignities. You need an adequate number of staff to position the patient- a minimum of five including the anaesthetist. Before you flip the patient disconnect the IV and have minimal bits attached to the patient to minimize the chance of them dislodging during the turn. Lying on an ECG dot that you can't access for three hours doesn't do the patient any favours. Arms need to be straight and by their side before the flip. The breasts, hips and bony protuberances need to be padded leaving enough room for respiratory activity. A pillow across the chest and pelvis usually suffices. Dedicated foam head pillows are worth their exorbitant price. The preference is always for the head and neck to be in neutral position. The elbows should be flexed and the upper arms not extended beyond the perpendicular. Put in the arterial line before any of this.

Both you and the surgeon must be satisfied with the positioning before letting the operation proper commence. A useful exercise is to imagine yourself lying like that and ask yourself whether you would be comfortable.

The IV and drawing up drugs

A bad IV doesn't get any better

“My dad sticks needles in people and gives them drugs.” This introduction given by one of my children to their classmates neatly encapsulates the core business of the anaesthetist. It also highlights that needles feature prominently as to how anaesthesia is perceived by our prospective customers both young and old. Here are some incontrovertible facts to ponder:

- No one likes needles.
- Needles hurt.
- If you do something a thousand times you will get very good at doing it.
- If you can't see or feel a vein you are unlikely to cannulate it.
- The quality of the cannulation sets the tone of the anaesthetic and is one of the few aspects of the anaesthetic the patient is likely to remember.
- The likelihood of cannulation success and the quality of patient mood is inversely proportional to the number of cannulation attempts.
- We all have our bad drip days.
- Some patients have crappy veins and it's not their fault.

Plan for success

Wash your hands before patient contact. Sit down and be comfortable. Bending over or kneeling on a hard floor is not comfortable or conducive to your hand being steady. It is preferable to only have one moving target. Have the patient's trolley at a comfortable height. This is a task that only requires one person to complete. Have all your bits and pieces at hand. I tuck a gauze square in my top pocket as insurance should I blow it. Put the tourniquet on, warn them it will be tight and get them to pump their fist. Organize the requisite paraphernalia while you wait. Choose a vein that you can at least see or feel. Patience and tapping the back of the hand often make a world of difference but don't slap the hand as it hurts. *Don't hurt the patient if you can avoid it.* Allow the skin to dry after you have alcowiped it. The main benefit of the alcowipe is to aid visualization of the vein of course. Avoid the volar aspect of the wrist, those veins are full of valves and it hurts like blazes. The cephalic vein reliably runs over the anatomical snuffbox and between the 4th and 5th metacarpal is another reliable location of a vein.

I recommend using local anaesthetic for cannulas bigger than a blue one (22 gauge). Needles hurt and if you miss you're already burning your bridges in terms of patient confidence and they are dreading the next attempt. A bleb of local does not make the vein disappear- that is nonsense. Many patients are pleasantly surprised when they are cannulated because they “expected it to hurt a lot more”. I don't use the hackneyed phrase “Just a little prick” because the patient might agree with you. My standard line prior to the local is “A big scratch now...” If you don't warn them an ‘ouch’ and scowl invariably emanates from your patient. Once you have chosen your spot don't prod it a hundred times- it isn't going anywhere and you are smearing your skin flora all over them. Insert at an angle to the skin, not parallel to it, and appreciate if you haven't got flashback after you've inserted half the cannula then there is

nothing to gain from further advancement. No one seems to have taught medical students this simple fact! Once you've got the thing in secure it with your favourite dressing. Don't use bandages- they don't secure anything, just hide badness.

The tough stick

If you've had three attempts and no joy you really should stop. You have nothing to gain by hurting the patient.

Your available strategies include:

- Having a break is mandatory
- Use local if you weren't previously (scared veins are vasoconstricted)
- Ask someone else to have a go (not the med student)
- Don't be proud- a small cannula in the antecubital fossa is better than a large bruise on the back of the hand.
- If you can't see anything get the patient to put on some surgical gloves and place a hot pack on their arms. This incurs a delay but has a high success rate.
- Use ultrasound- not wonderfully helpful in my personal experience.
- Put in a central line- sometimes you have to do this.
- Look at the foot- these are tricky and a short term option.
- External jugular vein- easy to see, very tricky to actually cannulate.
- Intraosseous line- The EZ-IO is a drill device that the emergency physicians like playing with.
- Get the radiologist to put in a PICC line.
- Gas induction- not if they are morbidly obese and have a difficult airway.
- Once in my career I have abandoned the procedure.

As an aside it is perfectly reasonable to cannulate the ipsilateral arm of someone who has had breast surgery including LN dissection. Similarly a BP cuff being applied will not precipitate doom. The only arm I would not cannulate is the one with lymphoedema or phlebitis. Ask IV drug users where their best vein is- they'll know better than you. If you keep hitting valves (50% chance of threading past them I reckon) and decide to proceed with one that is *just* in- be very cautious. This has a very good chance of extravasating and you need to be slow and gentle with your induction push. Connecting it to a bag of fluid will encourage it to blow.

Drawing up drugs

Drug errors can cause significant morbidity and should be considered avoidable. Drugs should be drawn up aseptically in a consistent manner with a minimum of distractions. I commend the following lifelong habit:

- Wash your hands
- Select an appropriate syringe and drawing up needle. Many centres use a syringe with a coloured barrel for muscle relaxants recognizing that drug swaps involving these compounds are bad news. Avoid sharps if you can and **never recap a sharp**.
- Next pick up the drug ampoule and *actively* look at it. By this I mean you have to convince your brain that you are holding the correct ampoule. I mentally read the label in a

deliberate fashion. Hospital pharmacies are forever changing what generic formulation they stock in the eternal quest to get the cheapest option. All clear glass ampoules look pretty much the same especially if they come from the same company. The anaesthetic literature is littered with adverse events resulting from individuals failing to appreciate what ampoule they were drawing up. My personal favourite is the report where digoxin was injected intrathecally on *three* separate occasions thinking it was lignocaine. Not surprisingly the spinals didn't work. The photo below was in the article with the caption "Indistinguishable vials". Indistinguishable apart from the fact that one has 'Digoxin' written on it and the other has 'Lidocaine'!



From A Bagherpour et al. Accidental Intrathecal Administration of Digoxin. *Anesthesia and Analgesia* 2006; 103: 502-3.

- Hold the ampoule so that the dot is facing you and crack it away from yourself. If the ampoule has a rubber stopper flip the cap off and puncture the rubber without touching it with your hand. Draw up the entire contents of the ampoule. Don't inject air into the ampoule- you'll just make a terrible mess and spray some in your eye if you're unlucky.
- Chuck the ampoule into the sharps bin. There is a growing body of ampoule collectors in my hospital. This is a futile exercise with an inherent risk of incurring a cut finger.
- Next add diluents if appropriate, it doesn't matter whether you use saline or water. Drawing up the diluent first is plain weird and quite awkward as the syringe is almost full and the plunger can't go back any further when you need to draw the actual ampoule up. Often you can't draw up the entire ampoule without needing to flick air out of the syringe and redrawing. Mixing is also probably impaired but not of clinical significance.
- **Now label the syringe before you put it back down on the anaesthetic trolley.** Dedicated labels are great but a permanent marker will suffice in their absence. I don't like pre-labelling. I think it subconsciously prejudices your brain when you are supposed to be *actively* looking at the ampoule. One label is perfectly adequate.
- If you used a sharp to draw up the drug twist it off the syringe barrel and chuck it in the sharps bin. Don't leave it attached. Minimize the chances of sticking yourself.

Similarly when you actually give a drug you need to actively look at the syringe to verify it is the intended one. If a syringe is unlabelled, partially empty when it should be full or you aren't sure about it- don't use it, throw it away.

By unwritten convention most anaesthetists draw up the listed drugs in the following syringes and dilutions:

Midazolam neat in 5ml syringe

Fentanyl/Alfentanil neat in 2ml syringe

Muscle relaxants in red barrelled 5ml syringe neat except for Vec which comes as a powder

Morphine/ Oxycodone in 10ml syringe, 1mg/ml

Antibiotics in a 20ml syringe- this also makes them easier to mix up

Atropine in 5ml syringe, 0.3mg/ml

Ephedrine in 10ml syringe, 3mg/ml

Metaraminol in 20ml syringe, 0.5mg/ml

Some words about emergency drugs

Like 100% oxygen, emergency drugs primarily function as an anxiolytic for the anaesthetist. Most theatres will have an amp or two of suxamethonium on the anaesthetic trolley. Their presence needn't compel you to draw them up. The same goes for atropine, ephedrine and metaraminol. The lag time to draw up sux is bugger all. I admit I routinely draw up atropine- bradycardia is a relatively common event on even mundane lists and is very cheap. It can also be used to make up reversal for the last case! Ephedrine and metaraminol are expensive drugs- an amp of each costs the taxpayer \$60. This is more than the cost of all the other drugs you would use in an average session. See '*The Cost of Things*' in Miscellany. If you can't abide splitting your metaraminol and use a new amp each time you give a patient a vasopressor then your routine practice rapidly and needlessly becomes a very expensive one. Vasopressor requirement is readily predicted- elderly patient, crap heart, neuraxial anaesthesia or all of the above. You will save thousands of dollars and maybe a few drug errors if you draw up vasopressors on a rational selective basis.

CHALLENGE QUESTIONS

1. What is Poiseuille's law and how does it relate to IV cannulae?
2. What are the contraindications for an intraosseous line? What drugs can't you give into an intraosseous line?
3. What's the best syringe to flush an IV line with?
4. If I draw up some sux that has been lying on the anaesthetic trolley for a week, will it still work?
5. How much adrenaline is in 15mls of 2% Lignocaine with adrenaline?

ANSWERS

1. Poiseuille's law refers to laminar flow of a Newtonian fluid in long, thin tubes. Although our vascular tree isn't quite like this ideal, an IV cannula is reasonably similar. The law says that flow is proportional to the square of the radius to the fourth power and the pressure differential across the tube. Flow is inversely proportional to the length of the tube. So if you want maximal flow through a cannula, you want one that is wide and short. A rapid infusion cannula best fits this bill. A central line is quite poor for delivering large volumes of fluid rapidly. The narrowest part of the giving circuit is the cannula; the maximal flow rate of a 20g cannula is 60mls/min whereas a 14g is 330mls/min and you can give a litre of fluid through a RIC in under a minute if the bag is pressurized.
2. Contraindications for placement of an intraosseous (IO) line are a proximal fracture or vascular injury in the limb, overlying infection and a previous attempt at the same site. Any drug you can give intravenously can be given into an intraosseous line. The pharmacokinetics and dosing are the same. Advise the lab if you take a blood specimen from the line as haemolysis and fat globules can alter some of the parameters but it is fine for a crossmatch. You have to syringe everything into an intraosseous line and it takes a little longer to get to the site of action so I probably wouldn't give adenosine through a tibial IO line as it will be chewed up before it has reached the heart.
3. A small syringe, 2 ml, is preferable because it will generate a higher pressure when you depress the plunger. Pressure is equal to force per unit area. All syringes have the same sized outlet orifice but different sized plungers; the smaller the better.
4. It will work fine despite what your colleagues and anaesthetic assistant might think. Suxamethonium retains its efficacy for *months* if stored at room temperature. The challenging part is finding an ampoule that old that hasn't already been thrown out!
5. There is 5 mcg of adrenaline per ml of a 1 in 200,000 solution which is the standard for local anaesthetic solutions containing adrenaline. So there is 75mcg in 15mls. No wonder that parturients are tachycardic when you do an epidural top up!

Induction of Anaesthesia

It's easy to put drugs into a patient but a lot harder to get them out

The preceding sections have detailed the preoperative assessment, formulation of an anaesthetic plan and drawing up the pharmacological tools of the trade. Now to the good part- actually giving the anaesthetic. This has been partitioned along conventional lines: induction, maintenance and emergence. The induction discussion will assume you are anaesthetizing a healthy adult subject with a LMA as the planned airway. I acknowledge some days this seems like an uncommon scenario.



Don't start without this person- your anaesthetic assistant

Once you and your assistant and the nursing staff are ready and a surgeon is physically present then you can bring the patient and their chart into theatre. The partial denture should already have been removed. Squirt your fentanyl in now. Transfer the patient safely and position them optimally on the operating table. Make sure the brake is on the patient trolley before they move across. The head should be on one decent pillow and the top of the head should be level with the end of the table. Have the table (“narrow and hard like an ironing board”) at a comfortable height, about level with your umbilicus. The ‘Jesus’ position is the preferred starting point for all GAs- both arms outstretched, legs straight and uncrossed. Connect the monitors and take a baseline reading. The BP cuff connectors should face cephalad (less likely to kink) and tuck the oximeter cable under the pillow (less likely to trip over it). I never use a 5 lead ECG as this only

gives two more leads the chance to become dislodged and generate artefact. 'White is right' helps remind you where to put the white ECG lead on a standard 3 lead set- the red one goes over the heart. Start the correct patient on AARK if you are in Queensland. Get the nurses and surgeon to do the WHO SSC final check now and not when you're trying to intubate the patient (See *Light Relief*). Have your anaesthetic assessment near to hand to remind yourself of allergies and the patient's weight and their name.

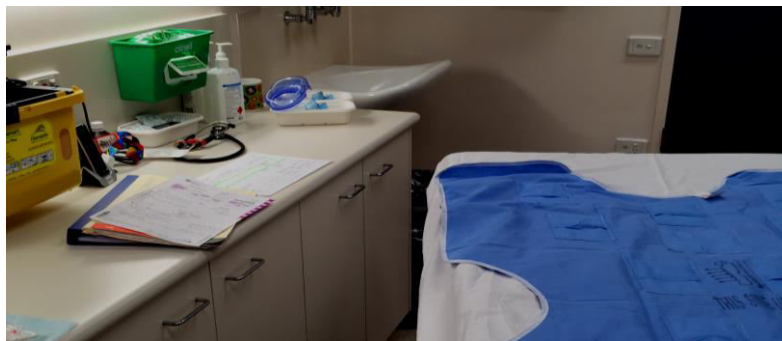

Forgotten something?

Don't start the induction unless you can hear yourself think. You should be calm, collected and confident. Turn the music off, it helps set the tone. Routine use of the sucker is noisy and unnecessary. Preoxygenate everyone by having the patient breathe "plastic flavoured oxygen" normally with a seal good enough to produce a capnogram. Your target is an end-tidal $F_{E}O_2$ 0.2 less than the $F_I O_2$ you have dialled up. If you are using alfentanil give it now and follow it up with the white stuff. Give the first five mls of propofol quickly but smoothly and then slow down so that you can see the plunger pass each gradation on the syringe. Everyone develops their own patter to say during this crucial phase. I say "We're going off to sleep now, *insert name here*, you might feel this medicine go up your arm. Keep breathing normally...I want you to keep your eyes open as long as you can..." I suggest you avoid words like burn and sting. This is not what you want to hear as you go off to sleep. I routinely add lignocaine to my propofol and gently rub distal to the cannula as I inject. My endpoint is loss of response to a verbal and tactile stimulus. I brush the patient's cheek with the back of my hand and say "eyes wide open *insert name here*" and if no response proceed to bag mask ventilation (BMV). I don't flick or brush eyelids because this is crude, can cause a corneal abrasion and is a less reliable endpoint. It is not the place of a book to teach one how to bag mask ventilate, insert an LMA or intubate someone so I won't. However I am compelled to make some points about BMV:

- It is the single most important manual skill the anaesthetist possesses.
- Like all skills it is improved with regular practice and every patient getting a LMA should be bagged prior to its insertion.
- You should be able to bag virtually everyone- 140kg patients with beards included.
- Have a low threshold to tighten the APL valve and use an oropharyngeal airway (OPA) as it makes a world of difference. (Appreciate that without the OPA your patient's mouth is closed and you are trying to force all the air through their nose.)

- Once you hand over the bag to your assistant for the two-handed approach your options are limited and your assistant's hands are effectively tied. You get much poorer biofeedback if you aren't squeezing the bag yourself. A better option is to get the assistant to improve the facemask seal. This is often achieved by 'scooping' the patient's cheek against the edge of the facemask. Frequent deferral to a two-handed technique reflects inadequate skill at BMV.

It is unusual to need more than one ampoule of propofol especially if you have injected it relatively slowly and actually waited for it to reach the effect site. If you have some left in your syringe after you've reached your endpoint then leave the syringe attached to the IV bung. As you pick up the circuit to commence BMV turn on the smelly yourself. Don't forget to do this- it has to become second nature. My default is 4% Sevo for the healthy subject. I don't use Desflurane for induction but you can, being mindful not to crank it up too quickly lest sympathetic stimulation ensue. Once you have practiced the vital skill of BMV and demonstrated that you are controlling the airway you can now instrument it.

The problematic LMA

Brimacombe describes twenty ways to insert a LMA. Most of us only need one; it usually just falls in. If it doesn't the commonest problem is that the patient is light. Remove the LMA, inject more white stuff (that's why you left the syringe connected), bag them a bit and then attempt re-insertion. If you are still not able to ventilate and don't think laryngospasm is the problem then remove it and bag again as your assistant prepares another LMA of your choice. How much air is in the cuff makes no difference to the quality of your airway seal. Changing the size of the LMA is similarly futile. Supreme LMAs often sit high whereas an i-gel can be shoved down lower. Jaw thrust applied by your assistant can be very helpful. Classics can be inserted using the reverse technique which negotiates the soft to hard palate curve in the oropharynx better than most devices which can only be inserted one way. This is a common problem in petite women and older children. Use of a laryngoscope can be helpful and should stop the LMA from folding over itself or pushing the epiglottis over the glottis opening. All anaesthetists should be familiar with and have practiced Brimacombe's bougie guided technique. This entails passing a bougie down the gastric port of a Proseal or Supreme LMA and with gentle laryngoscopic guidance passing the tip of the bougie into the oesophagus. The LMA is then railroaded down the bougie into position. A picture of a prepared Supreme LMA is below. A nasogastric tube is an alternative to a bougie. Brimacombe reports an astonishing 100% success rate with this technique. Since he is the world's most experienced user of LMAs I would not trivialize this claim. If you are still struggling the airway will be traumatized by now and you should cut your losses and intubate them.



LMA in search of the oesophagus and a quality seal with the glottis

If the LMA is not right it will continue to cause you grief for the entire case. If the patient is breathing spontaneously this will often give you a reasonable airway despite a leak. Increasing the fresh gas flow; placement of a NGT and paralysis are other tricks to try should you choose to persist with an LMA that has a leak.

Brief words about the routine intubation

At least consider what plan B is should you not be able to intubate them on the first couple of attempts. Start the timer once the relaxant is given and don't forget to apply the twitchometer. The practice of test ventilation, demonstrating you can bag mask ventilate *before* you give relaxant, is an arcane one and I strongly commend the editorial by Yentis listed in the *Selected References* below. In summary if you are struggling to bag your patient then relaxant is likely to help the cause and *should* be given. Unfortunately after patients have had an amp of midazolam, fentanyl and propofol they don't magically wake up and start breathing adequately when you discover you can't bag them effectively. Auscultate after you've intubated in both axillae only and tie the tube securely. I do a knot against a knot tight enough that I can just about lift the patient's head off the bed by pulling on the tube but not pull it out! I do not consider micropore or sleek as adequate or reliable methods to secure the tube. Remember there are only two reliable ways to confirm the tube is in the right place-see the end of *The Anaesthetic Machine* chapter to refresh your memory.

The 'end' of the induction

Once you are happy with the airway you can switch the patient over to the ventilator. It makes sense to have already programmed the ventilator settings prior to induction but trainees seem to perennially forget this and happily accept the default VCV setting. There are only three choices of ventilator settings- volume controlled, pressure controlled or pressure support ventilation. The latter is a spontaneously breathing mode where the patient triggers pressure support during inspiration. There is no outcome based evidence to favour a particular ventilatory mode. I choose SIMV-PC as most patients will be apnoeic post induction and I prefer a pressure limit to minimize leaks around my LMA. Once the patient starts breathing it is a simple task to flip

them onto pressure support. Should they stop breathing the back-up PCV mode will become active.

Lastly it is good practice to step back and scan the scene to ensure all is well: the drip is dripping, monitors are all functioning, the end-tidal reading confirms that you are giving an anaesthetic (if it is volatile based), the ECG looks okay and the warmer is turned on. You should be able to see the patient's head unless the surgeon is operating on it- visual cues often precede badness which precedes the activation of auditory alarms. The induction is not complete until you have indicated to the surgeon that they can start and you've documented it all on the anaesthetic record. Don't relax too much though as you are about to enter the underrated maintenance phase of anaesthesia.

SELECTED REFERENCES

Editorial. Could 'safe practice' be compromising safe practice? Should anaesthetists have to demonstrate that face mask ventilation is possible before giving a neuromuscular blocker? I Calder and S Yentis. *Anaesthesia* 2008; 63: 113-5.

Gum elastic bougie-guided insertion of the Proseal Laryngeal Mask Airway, J Brimacombe and C Keller. *Anaesthesia and Intensive Care* 2004; 32: 681-4.

LIGHT RELIEF

Surgical Safety Checklist		(Affix identification label here)	
Date: <input type="text" value=" / /"/>	URN:	Family name:	
	Given name(s):	Address:	
	Date of birth:	Sex: <input type="checkbox"/> M <input type="checkbox"/> F <input type="checkbox"/> I	
Document variances on pages 2-10			
All checks must be performed when at least one person is busy performing a task necessary for the completion of the procedure			
1. Patient Consent: = at least one problem identified			
2. Site marked: = Yes, if could find pen = Yes, if could find surgeon = Not sure if this one needs it			
3. Anaesthesia Safety Check: = Yes, have heard of it = Yes, anaesthesia have a checklist = Yes, anaesthetist confirms they are wearing protective equipment			
4. Allergies/ adverse drug reactions/ dietary requests/ phobias: = Have painstakingly detailed a list of information on pages 2-4 = Haven't clarified if any of this is clinically relevant			
5. Known alert(s): = Something is written in the margin of the theatre list beside patient's name = Really fat or MRSA or mad or cognitively impaired			
6. Risk of blood loss > 500 mL: = Yes, if registrar is doing case = Not likely but never say never			
7. Surgical equipment, imaging, prostheses: = At least one of these is missing/ wrong/ broken			
8. Thromboprophylaxis = Theatre assistant has remembered to put TEDS/ SCDs on = Surgeon has forgotten chemical prophylaxis again			
9. Patient medications: = At least one has been inappropriately given or withheld			
10. Confirm at least one team member: = is unknown to the rest of the team = has never seen the procedure before = knows what they're doing			
11. Antibiotic prophylaxis: = has not been ordered by surgeon, but = has already been given by the anaesthetist as per usual			
12. Pressure injury prevention plan implemented = Yes, has been filed in PAC paperwork somewhere			
13. Anticipated critical events: = Yes, we anticipate something critical will happen			
14. Nurse confirms in a clear voice: = name of procedure, count is correct, specimens are labelled and; = no one pays any attention to them			
15. Specific concerns for postoperative care: = are left to the PACU nurse to determine			

Maintenance of Anaesthesia

Mr Anaesthetist- if the patient can keep awake then surely you can
Wilfred Trotter, Surgeon

An alternative title for this chapter could be “How not to get bored once the patient is asleep”. While it is true that this is usually the most unremarkable phase of proceedings as far as the anaesthetist is concerned it is when the business proper is occurring, i.e. surgery is happening. The maintenance phase doesn’t mean you should switch off your brain and switch on your i-device. Vigilance requires a degree of arousal but it is not enhanced by having an iPad perched on your lap. There are a host of activities that merit your attention more than your email inbox.

Things you should be doing

Is your anaesthetic set up appropriately? Have you decreased your fresh gas flows to about a litre a minute? Any more is wasteful. If you don’t care about wasting money then spare a thought for the ozone layer. Concerns about using Sevoflurane at this FGF are invalid.

Is your MAC appropriate and age adjusted? If you are giving a TIVA you need to institute some means of regularly checking that your syringe driver is actually delivering white stuff. This is not achieved by glancing occasionally at the BIS reading! One method is to look at the syringe driver after each NIBP cycle and confirm that the drip is dripping, the syringe is emptier than last time and noting the current pump rate.

Are you providing adequate analgesia? Now that the surgeon is breaching tissue planes and the induction fentanyl is subtherapeutic courtesy of redistribution? Titrating analgesia is more art form informed by experience than science. Giving a milligram of morphine every time the heart rate picks up is pretty crude. If the patient is breathing spontaneously then titrating to a respiratory rate of ten or so is a quite reasonable target. Even if the patient is ventilated they will be breathing for themselves at the end of the case. If they are chugging along at twenty a minute there’s a good chance they’ll wake up sore. Heart rate changes are to be expected in response to surgical interventions so a better action when the rate jumps is to peer over the drapes and see what the surgeon is doing.

Have you completed the anaesthetic record? Fortunately this takes all of thirty seconds with AARK. If you had difficulties managing the airway the record should reflect this to help your colleague in the future.

Have the postoperative orders been done? This includes fluid orders (100mls/ hr of normal saline is my default), charting analgesics, antiemetics and doing all the APS paperwork and stickers if relevant.

Have you attended to the ‘Antis’? I am referring to antiemetics (a long operation merits a long acting agent), antibiotics (preferably before the tourniquet went on), anti-inflammatories (is there a reason not to give parecoxib) and anti-thrombotics/fibrinolytics (if the surgeon forgets

to do these the nurse will chase you and the patient bears the consequences if neither of you do it).

Next to consider is a heterogeneous group of matters that merit an acronym but I can't think of a good one so instead I'll use a collective term- measurements. Fluid input and output. Urine output is decreased by anaesthesia but anuria and marked oliguria should precipitate further investigation on your part. Blood glucose levels should be done hourly on diabetic and critically ill patients. Blood loss is best assessed by objective measurements- a hemocue is as good as a formal FBE only quicker, especially if you use an arterial line sample. Should you do a gas for that matter? Finally temperature management is to be considered. Perioperative hypothermia is very bad for your patient and the routine use of forced air warming is the norm. Actually measuring body temperature is unnecessary because it is virtually impossible to 'cook' patients. The sole exception being the febrile patient, even then their temperature will fall during the case. Allowing a patient to get cold should almost be regarded a criminal offence. A major case should be pre-warmed, especially in winter.

Finally list management is to be addressed. When to send for the next patient? What is the next case? Have you had a break? You're not in private practice; you are allowed to take one. What preparations can you make for the next case?

If you have dutifully attended to all of the above and you are with a boss now is the time to ask them a clever question. They are there to teach, you are there to learn. You need to make it happen, though. See *How to learn anaesthesia* for inspiration.

A brief primer on perioperative hypothermia

'Mild' perioperative hypothermia is bad for your patient. Our enzyme systems are designed to function optimally at 37 degrees; they don't do so well at 35 degrees and below. Apart from shivering and the unpleasantness of feeling cold (termed thermal discomfort) there are significant adverse effects associated with hypothermia including increased adverse cardiovascular events, immune suppression and impaired wound healing, bleeding primarily due to platelet dysfunction and prolonged duration of action of muscle relaxants. MAC is reduced by about five percent per degree fall in temperature. Anaesthesia constitutes a major trespass upon our normal thermoregulatory mechanism which is coordinated by the hypothalamus. Core body temperature is normally tightly regulated and our main defence against heat loss consists of behavioural changes as well as activation of the sympathetic nervous system to cause vasoconstriction to minimize heat loss to the environment. Anaesthesia prevents the ability to go and put a coat on, decreases metabolic heat production and most importantly causes a dose dependent reduction in the vasoconstrictor response. The interthreshold temperature change required to trigger vasoconstriction is increased twenty-fold from 0.2 to 4 degrees. It is useful to consider the classic diagram reproduced below which demonstrates the fall in body temperature of an anaesthetized individual if no preventative measures are taken.

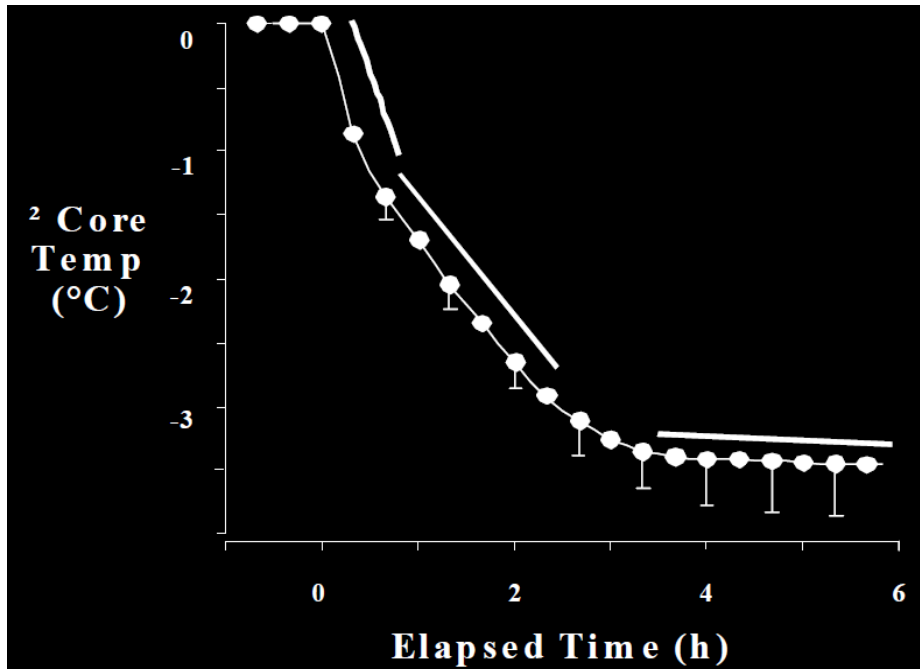

There are three phases to the graph. Initially there is a relatively large rapid fall of a degree or so that occurs as a result of redistribution of blood from the cooler outer shell mixing with the warmer core body compartment. Normally vasoconstriction of arteriovenous shunts in our skin maintains this gradient. Anaesthesia induced vasodilatation disrupts this gradient. In the second phase of the diagram there is a further fall in body temperature that is less steep. This reflects a state where heat loss exceeds heat production. The latter is relatively fixed. There are four mechanisms of heat loss: radiation, convection, conduction and evaporation. Radiation is the most significant contributory mechanism and the rate of heat loss is dependent on the difference between the body and the ambient temperature to the fourth power. If you increase the theatre temperature to minimize this differential you will certainly reduce the degree of heat loss, however everyone else in the theatre will be unbearably hot! Anaesthetized patients behave like poikilotherms to a degree until body temperature has fallen low enough to finally trigger vasoconstriction again. When this happens a plateau temperature is maintained however this is several degrees below normal. If the patient has a sympathetic block as well, eg. courtesy of an epidural, then they will not achieve a plateau; rather body temperature will continue to fall as vasoconstriction is impaired. Forced air warming is so effective because it actually inputs heat energy into the patient. Reducing heat loss is not enough. Warmed fluids do not prevent hypothermia nor does a mountain of blankets.

Desaturation during the maintenance phase

Before we discuss waking the patient up I have a few words about one of the most common intraoperative problems that anaesthetists manage in the maintenance period. This is desaturation. Any time the sats dip should elicit a reflex triggering of the hypoxia drill being enacted. Often a truncated version is all that is warranted depending on the context. See

Hypoxia in the Crises section. The commonest cause of desaturation in an intubated and ventilated patient is V/Q mismatch as a result of atelectasis. Importantly this is a diagnosis of exclusion. Increasing the $F_{I}O_2$ will improve the sats but not rectify the problem. The problem is temporarily rectified by alveolar recruitment manoeuvres. Since these are similar to performing a Valsalva and will markedly reduce preload you must ensure a decent BP before embarking on them. Increase FGF, decrease volatile (BP is already going to be hammered), increase $F_{I}O_2$ to a maximum of 0.8 (100% O_2 causes absorption atelectasis), take the patient off the ventilator and close the APL valve to 40cm H_2O . Squeeze the bag and hold it for eight seconds looking at your watch then release. If you didn't already have PEEP on, now is the time to apply it. Then flick the patient back onto the ventilator and readjust your FGF and vaporizer settings. If the sats didn't improve after all this you have a huge shunt or a defective oximeter.

SELECTED REFERENCES

H Rothen et al. Dynamics of re-expansion of atelectasis during general anaesthesia. *British Journal of Anaesthesia* 1999; 82: 551-6.

CHALLENGE QUESTIONS

1. Why is pre-warming so effective?
2. A patient becomes hypotensive and their end-tidal CO₂ decreases. Why is this? Why might they also desaturate?
3. Is it possible to drink too much coffee? What do you know about the pharmacology of caffeine?
4. Do mobile phones interfere with the function of syringe drivers and electronic equipment?

ANSWERS

1. Pre-warming is so effective because it prevents the initial redistributive phase where core temperature falls a degree or more relatively rapidly. It prevents this by inducing vasodilatation of the skin slowly in tandem with supplying exogenous heat energy. The cool shell is effectively being warmed.
2. This is normal physiology in action. Hypotension causes an increase in alveolar dead space due to ventilation perfusion mismatch. The apical parts of the lung are less well perfused than the lung base so in the event of hypotension, apical segments are ventilated but not perfused. This is West's Zone 1. Because CO₂ is not being delivered to these alveoli and there is no CO₂ in the inspired gas, the expired gas has a decreased concentration of carbon dioxide. If there are enough lung segments involved, oxygen transfer will be impaired enough to cause desaturation.
3. Short answer is no. The fatal dose is thought to be around 10 grams. There is about 100mg of caffeine in a cup of coffee so you would need to drink about a hundred coffees in short time to achieve this potentially lethal intake. Caffeine is the most widely used CNS stimulant in the world. It is a methylxanthine (like theophylline) and has a mean half life of five hours. Peak plasma concentrations are achieved 15-30 minutes after ingestion. There is no first pass metabolism although caffeine is metabolized by the liver. The volume of distribution is 0.7 l/kg which is the same as total body water. Caffeine readily crosses the blood brain barrier. The elimination half life is quite variable. Caffeine metabolism is not altered by repeated administration but it is increased by smoking. The liver metabolizes it predominantly by demethylation to paraxanthine which is excreted renally. This is a first order process. Paraxanthine has a longer half life than caffeine and is an active metabolite and a fall in its levels may contribute to withdrawal in regular caffeine drinkers. A degree of tolerance may develop to caffeine. The predominant mechanism of action of caffeine is via competitive antagonism of adenosine receptors. It is also a weak inhibitor of phosphodiesterase enzymes. The pharmacodynamic effects of caffeine include:
 - CNS stimulation
 - Bronchodilation
 - Cardiac stimulation
 - Diuresis
 - Lipolysis
4. No. The manufacturers recommend not using them in proximity, though. However ringing phones are undoubtedly a distraction.

LIGHT RELIEF

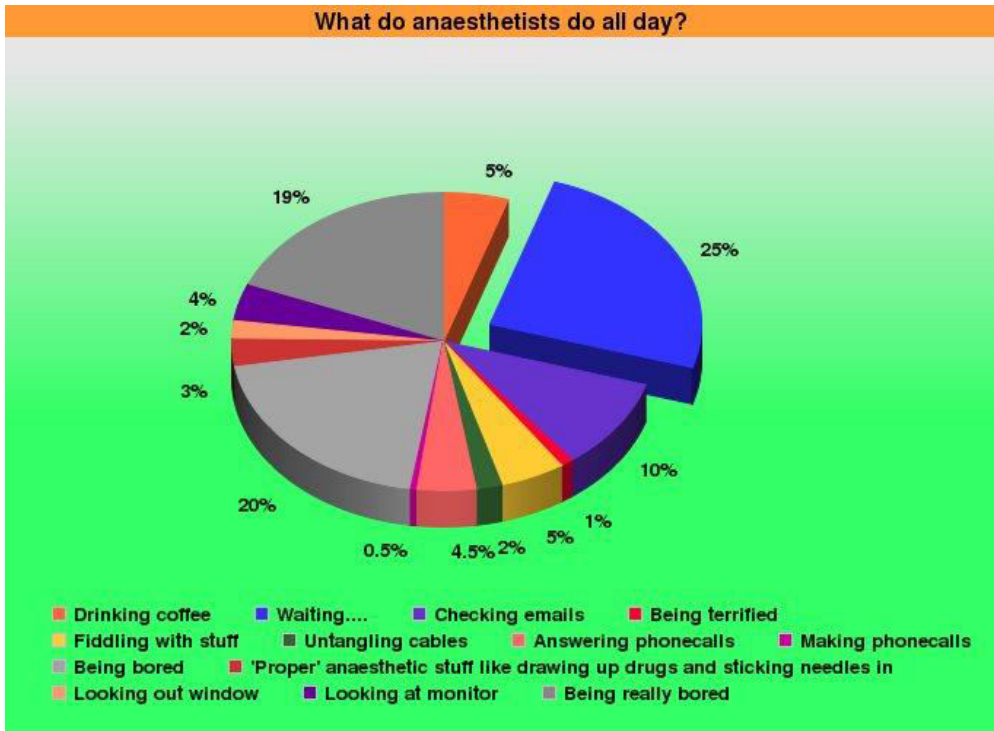

Emergence

Those that face heaven are more likely to end up there

Unless you are a cardiac anaesthetist this phase of the anaesthetic deserves every bit as much attention as the induction. This is a high risk period and I am often more anxious about the extubation than the intubation. The emergence period has belatedly but deservedly got some recognition in the anaesthetic literature recently. Unpleasantness in the PACU and coroner's reports have prompted this attention. There is increasing awareness that poor management of emergence can lead to adverse outcomes.

This discussion will focus on the intubated patient as one of the great benefits of a laryngeal mask is that it is designed for the patient to effectively recover themselves. As long as they are breathing they can be deposited in PACU and allowed to wake at their leisure as you get on with the next case. A gentle emergence with a LMA has many benefits- less delirium; less sympathetic stimulation and attendant hypertension and tachycardia which is undesirable if your patient is on the verge of myocardial ischaemia; much less coughing, tube-biting, grimacing and testing of the surgeon's hernia repair by bucking on the tube. All this goodness is undone if you turn off the smelly too early, let the patient lighten and then stimulate them by moving them off the operating table. Patient transfers constitute a stimulating event. The vaporizer is the last thing you touch for the patient with a LMA. The LMA is designed so that the patient effectively wakes by themselves. The ability to perform a smooth extubation is a valuable one and is a skill you should aspire to possess.

Criteria for extubation

You need to have these clear in your head. All of these criteria need to be assessed but not necessarily satisfied before you pull the tube. We will consider them in detail.

- Adequate level of consciousness- there is huge variability in how this criterion is assessed. The commonest method would be whether the patient opens their eyes on command. If they do open their eyes on command they probably do have an adequate LOC but just because they can open their eyes doesn't mean they've bought a 'pull my tube this instant' card. Conversely if all the other criteria have been satisfied and they are writhing around but not opening their eyes in response to your imprecations then you are not achieving anything by prolonging the agony. Some patients just don't seem to like opening their eyes. An alternative I often use is to ask them to "stick out your tongue". A host of crude practices are practised in attempts to 'wake the patient' who is still enjoying their anaesthetic. The patient needs to have an end-tidal MAC of 0.3 or less before you even start poking them. If they have pin point pupils it is a futile exercise expecting them to respond to your commands. I discourage pinching, poking and flinging your patient's limbs around in an attempt to wake them up. An effective manoeuvre to deliberately stimulate the patient that doesn't harm them is to flex their head forward. If there is no response to this then you just have to wait longer. Obviously if you are doing a deep extubation this criterion isn't satisfied. This is discussed below.

- Return of protective airway reflexes and adequate muscle strength- clinical criteria are unreliable but if they can squeeze your hand hard enough to hurt and you need two wardsmen to hold them down on the bed they're probably okay! If muscle relaxants featured in the anaesthetic then the twitchometer should be in use and the patient should have attained the magic target of a train-of-four ratio (TOFR) of 0.9 or greater. Not being able to feel a difference on double burst stimulation would also be satisfactory if you don't have a quantitative monitor in use.
- Adequate oxygenation- their sats should be fine at the end of the case especially since most will be breathing close to 100% oxygen. If they can't maintain their sats with a patent ETT and high F_IO₂ they'll fall apart when you remove it. If they are requiring more than 5 of PEEP or any pressure support they will also struggle when extubated.
- Adequate ventilation- if the patient is in ICU there is a whole battery of parameters described in the textbooks that can be measured before extubating the patient. In theatre we keep it simple. The patient's respiratory activity must have all of the following qualities: it must be unassisted (off pressure support), regular, of a reasonable rate (between 10 and 20) and most importantly of a reasonable tidal volume (a couple of hundred mls at least). An end-tidal CO₂ of seventy is generally not consistent with adequate ventilatory effort.
- Haemodynamics are stable- if everything else is okay but they are hugely tachycardic or hypotensive then taking away the secure conduit of oxygen is probably not a good idea. (Also acknowledge that patients can't help but be sympathetically charged if they are wide awake with a piece of plastic between their cords.)
- ETT is not acting as a stent- usually this is not the case. But after a long Head and Neck operation for example the patient may have significant airway oedema which manifests as obstruction when the tube is removed. The easiest way to exclude a worrying degree of oedema is to deflate the cuff and see if there is a leak.

Technique of extubation

This is something addressed poorly in the textbooks. There is huge variability in practice. Obviously you should assess whether the patient has satisfied the criteria described above. You should be proactive and anticipate when the procedure is likely to end- turn off volatile (but keep flows low until you are close to waking), administer reversal, make sure your assistant is in the vicinity, the wardsmen are on their way with the bed etc. You look silly if the first you know about the procedure finishing is hearing the surgeon chirping "I'm done" and them snapping their gloves in the bin (this behaviour should be discouraged incidentally).

A word about weaning- if the patient isn't already breathing for themselves then generally just taking them off the ventilator is a futile exercise. Decreasing the respiratory rate is similarly unrewarding, they will happily let the machine breathe for them at whatever reduced rate you've selected. You either leave them on the ventilator until they start to fight it or you take them right off it and be prepared to wait *several minutes* for their CO₂ to rise to the threshold value for spontaneous ventilation. You need to have blown off the volatile to at least 0.3 MAC or less before you do this, though.

Position- the lateral or recovery position is the default position to wake your patient in. Generally it is preferable to extubate the patient on the trolley and not on the operating table. You don't want them thrashing around and falling off the table. Trolleys have rails and operating tables don't! Put them on their side so they are facing you and your anaesthetic machine- this may be left lateral or right lateral depending on the theatre layout. Patients maintain their airway far better on their side. It is also easier to apply jaw thrust which is the most useful airway manoeuvre bar none. Being supine lends towards airway obstruction hence the quote at the start of this chapter. There are two exceptions to the lateral position being the default position for extubation. One is where the patient is thrashing about and clearly ready to be extubated. In this situation it doesn't matter what position they are in, you need to get rid of the tube before they injure themselves. The other is the obese patient. It is the lesser of two evils to have them on their backs but sitting up to take the weight of their abdomen off their chest. Obese patients are generally all extubated awake.

The sucker- This device has only two purposes: sucking stuff and to stimulate the patient. If there is nothing to suck then you are stimulating the patient. The common barbaric practice of ramming the sucker needlessly down the patient's throat at the end of the operation when the patient is still on their back on the operating table with the tube in situ merely stimulates the patient- coughing, gagging, making the ventilator alarm and putting the patient in danger of rolling off the table. Only use the sucker if there is stuff to be sucked, you want to stimulate the patient or you are just about to pull the tube. You should gently introduce the sucker alongside the teeth not force them apart with it.

To bite block or not to bite block- I don't recommend routine use of bite blocks. They are a good way of causing dental damage. They are not required as a routine. If you have a patient biting on the tube and you are worried about them occluding their airway and developing negative pressure pulmonary oedema then simply deflate the cuff! An oropharyngeal airway is not a bite block- it is a device used to keep the airway patent. If the patient bites down hard on these they will crack a tooth. If you do want to use a bite block then some rolled up gauze is a better option.

Actually pulling the tube- Be prepared, loosen the tapes if you have used these to secure the tube, cut the tie if you have knotted it and have the syringe and mask handy. Your assistant should be there with these ready for you. If you haven't sucked them out at all you can do it now then deflate the cuff and pull the tube. Some textbooks describe the curious business of closing the APL valve and pulling the tube while the patient is exhaling. This is an unnecessary manoeuvre and requires a synchronization of events that is rarely realized in practice. (The theory is that the patient will cough and expel any mucus or rubbish out of the glottis as opposed to inhaling same. But that's why you sucked them out, isn't it?)

Last things to consider- Before you leave the theatre convince yourself that the patient is still actually breathing and maintaining their sats after you've extubated them. The oximeter is always the last monitor to be removed. Better to recognize apnoea now than in recovery. Hit the 'patient left theatre' button on AARK, collect the patient's chart and dentures and glasses and x-rays and depart the scene.

Deep extubation

The crucial word is 'deep'. Badness happens when patients are light and then stimulated- bronchospasm, laryngospasm, aspiration and tube-biting are all things we'd like to avoid. Justify this practise- why are you doing it? Is it to facilitate a gentle emergence, is it to speed up turnover time or is it because you're impatient? You must be sure that the patient is breathing adequately and will maintain their airway when you pull the tube. Any airway manoeuvres like suction, inserting an oropharyngeal airway or exchanging the tube for a LMA should all be done while the patient is still deep. If when you poke the sucker in the patient grimaces or stops breathing, this is an indication they are not deep enough.

The patient who won't wake up

You need to be systematic and consider each of the following:

- Have I stopped administering anaesthetic drugs? The propofol pump is stopped, the vaporizer is off and the end-tidal concentration is appropriately low.
- Are they still paralysed? Put on the twitchiometer if you haven't already.
- Are they narcotized? Pin point pupils suggest that this is the case. You will need to wait or antagonize the opioid with small doses of naloxone.
- Are they hypothermic?
- Are their parameters all okay? - if they are hypoxic, hypotensive or hypercarbic then they won't be responding much as their brain is not operating optimally.
- Are they hypoglycaemic? It is quick and easy to check their BSL and very embarrassing if this is the problem.
- Still no joy? Have they had a neurological event- examine them for focal signs. Stick a BIS on them; a low reading would be cause for concern. Are they seizing? If you haven't already done so, take some bloods including an ABG and do an ECG. A trip to the CT scanner is next on the agenda.
- Pseudoseizures or the patient 'foxing' is a diagnosis of exclusion but accounts for all of the really weird delayed emergences I've had in my career. It is not unreasonable to do at least one sternal rub or press a pen over their nail bed to try and elicit a response.

Handover to recovery

At a minimum your handover to the nurse in recovery should address all of the items listed below.

- Apply brake on patient trolley
- Apply monitoring/ supplemental oxygen
- Handover to a responsible person (not the nursing student)
- Demographics- patient name, what operation they've had and by whom
- Mode of anaesthetic/ analgesics given/ antiemetics given/ drains and catheters/ any intraoperative problems
- Post-op plans- where is patient going after recovery; confirm that post-op orders and APS paperwork if relevant have been done
- Anything you want done in recovery specifically- eg. BSL, hemocue, warmer on
- Check 1st set of observations are satisfactory before wandering off

- Check nurse is 'happy' and that they know how to get hold of you
- Wash your hands
- You are the primary person responsible for that patient until they have left recovery.

How to do a spinal (& an epidural)

Double everything the surgeon tells you

Competent and safe conduct of major neuraxial blockade is a core anaesthetic skill. It is learnt by doing blocks on patients. Below is a synthesis of the absolute core information you should know as well as a suggested technique and an explanation of its elements.

Before you start

Why are you doing this in the first place? Is it for anaesthesia or analgesia or both? A spinal is good for anaesthesia for procedures being performed on the lower half of the body especially from the umbilicus down. Although you can use it for supraumbilical procedures there is an increased risk of inadequate anaesthesia for these and generally a spinal is not recommended. A spinal will generally be good for a maximum of two hours surgical anaesthesia and often less if a reduced dose is used. Most people work on one hour actual operating time. If you think the procedure will take two hours or more then don't rely on a spinal to last the duration! Note the aphorism above. If the ortho reg says it'll take an hour then it will take two- you have been warned.

Procedures commonly done under a spinal:

- LSCS
- Joint arthroplasty
- Open inguinal hernia repair
- Urological procedures
- Orthopaedic surgery on the lower limbs

Next consider are there any contraindications to the procedure.

Absolute contraindications to a spinal are:

- Patient refusal/ no consent- this is an absolute contraindication for every procedure needless to say. (As is lack of appropriate equipment and assistance etc.)
- Localized sepsis at the intended site of needle entry
- Untreated coagulopathy- usually defined by lab parameters. This includes current antithrombotic drug therapy. More about this in the Perioperative Medicine section.
- Raised intracranial pressure- in a patient who does not have the capacity to accommodate for a sudden reduction in CSF pressure. The risk is of the patient coning due to herniation of the brainstem.

There is a very long list of relative contraindications which I won't detail. I will say that generally speaking most people would not site a spinal in the following situations:

- patient is febrile or systemically unwell (concern is seeding neuraxial infection)
- patient who is obtunded, combative, demented (concern is can't assess neurological function adequately nor position properly)

- patient with active neurological disease/ signs (concern is spinal may worsen condition which is generally an unfounded concern and block may impair ability to monitor neurological signs postoperatively)
- hypotensive/ shocked (concern is sympathetic block will exacerbate this further and may precipitate cardiovascular collapse.)
- relatively fixed cardiac output state eg. Aortic stenosis. (concern is a rapid drop in preload and more especially afterload can precipitate decompensation and cardiovascular collapse.)

Next consider what to tell the patient. What are the benefits and risks of this procedure for them? Any risk-benefit discussion needs to be informed by the context of the specific procedure, patient factors and proceduralist factors. If we make a few generalisations then the benefits of a spinal are:

- Reliable, quality surgical anaesthesia (for a limited period of time)
- Excellent quality analgesia without opioid side effects.
- Low incidence of PONV- providing blood pressure is managed appropriately.
- Avoidance of need to manipulate or instrument airway and consequent avoidance of adverse physiological response to these. This is particularly desirable in a patient with poor respiratory function, active bronchospasm or chest infection.
- Avoidance of need to secure airway which may be an attractive option if this is likely to be difficult.
- Possible decreased blood loss and decreased incidence deep venous thrombosis.
- Avoidance of other anaesthetic drugs eg. Volatiles, muscle relaxants.

The risks to make your patient aware of include:

- Failure of the technique- this is variably quoted at between one and two percent and can happen even to experienced practitioners. The good news is we can reliably test and determine whether our spinal is working before embarking on surgery. Failure may result from inability to get the spinal in at all, from incomplete or partial block and from it wearing off before surgery has been completed. For this reason you must ask yourself what you will do if any of these events occur. A reasonable proposition is that you should be prepared to give your patient a general anaesthetic in the event of failure of your technique.
- Postdural puncture headache (PDPH)- similar incidence as failure is often quoted but in practise is much less with small calibre pencil pointed spinal needles. PDPH will resolve in time in the vast majority and there are effective treatment options for it.
- Patient should be aware that a spinal will tend to lower their blood pressure and often requires pharmacological measures on our part to maintain it; their legs will be heavy and numb for several hours; they may need a urinary catheter for urinary retention. You should explain that some degree of sedation is invariably given in association with the spinal and explain they may be aware of some aspects of the procedure depending on the degree of sedation. If sedation is not given then this should be explained to the patient also. Most patients don't want to be wide awake and it is unreasonable not to provide a degree of sedation.

- Brief but explicit mention should be made of rare adverse effects- high block, nerve damage, infection, epidural haematoma. These are all very rare and this should be impressed upon the patient. I generally tell the patient that we avoid these with careful, safe technique which is true. The incidence of nerve damage is very similar regardless of the mode of anaesthesia as most nerve injuries are related to surgical factors and patient positioning.

Despite what medical registrars may think and tell the patient there is no evidence that a neuraxial anaesthetic is 'safer' than a general anaesthetic. There is data suggesting the converse is the case. The anaesthetic you give a really sick patient is a general anaesthetic. More on this can be found in the '*Risks of anaesthesia*' chapter above.

Doing the deed

Okay, having established that a spinal is appropriate and gained informed consent from the patient we now consider the technical aspects. A useful mnemonic when setting up for any regional anaesthetic is CIMPLE: Consent, IV access, Monitoring, Positioning, Landmarks, Evaluation.

Make sure your drip works and is of adequate size. Pink (20g) at least. Preloading with crystalloid is unnecessary whereas having a well running drip is necessary. Have a vasopressor drawn up ready. Take a baseline BP and start the DINAMAP cycling and stick an oximeter on as a minimum. Sedation is not warranted and is generally undesirable at this stage as it interferes with patient positioning and evaluation of the block. Check the medication chart to make sure they're not on any antithrombotics or been given 80mg Clexane that morning.

Position the patient- usually it is best to sit the patient up with their legs hanging over the edge. If the patient has a fractured femur you can't do this! Positioning is key to success so you need to be able to explain to your patient what you want. They need to be on the edge with knees against the mattress not so they feel like they're falling off. The bed or trolley needs to be flat. Put a pillow across their lap and fold their arms across it-i.e. cuddling it. The patient then needs to assume the 'scared cat' position- chin down on chest, shoulders slumped forward and pushing their lower back out, i.e flattening out the normal lumbar lordosis. The patient needs to be relaxed, not swayed to one side, not tensing every muscle in their back and holding their breath! Same applies for the proceduralist. Commonest errors I see is the patient slumped forward too much, their back should be perpendicular to the floor and the patient not extending their back. The normal inclination is to do the reverse when someone is grinding their finger in your back- tell the patient to 'push out against my finger'. Keep your finger in place so they have something to push against and you can feel them doing the desired manoeuvre. It is handy but not essential to have an assistant standing in front of the patient to steady them and assist with positioning. This should not be an ordeal for all concerned. Expose the patient's back entirely and stick a bluey under their bottom. Note if they have a huge carbuncle, scar or deformity over their lower back (should have already done this with your assessment).

The next sequence of events I have described over a hundred times to trainees so here goes:

- Scrub up properly- gown, gloves and mask. Closed glove technique should be used. If you can't scrub properly get a scrub nurse to teach you.
- Get your assistant to open the spinal pack. Do not draw any drugs up at this stage. Get your prep gear- current recommendation is to use 0.5% chlorhexidine in alcohol (it makes no difference what you use). This is tinted so you know where you've been and it looks like beetroot juice. I put the prep pot (called gallipot if you want to impress) with two gauze swabs inside on a plastic tray with the sponge holding forceps. Once you pick up the prep tray you do not put it back on the trolley! Warn the patient that you are about to paint their back with some very cold solution (latent heat of vaporization). Then paint a nice big canvas for yourself- cover the lower half of their back. I start from the top and in horizontal strokes work down. When I get to the bottom I discard the swab and use the second one and repeat the process. Some people do circles and do it three times- I think this is awkward and silly. Then hand off the prep tray so it is separate from the spinal trolley. Next put the sterile drape over their back- just use one. Don't peel the paper off the sticky bits- you don't want glue on their back nor peeling the prep off when you have to reposition the thing. Unfurl the drape to the side of the bed and work out which way is up. Then in one smooth movement place it on the patient's back with the window over their lumbar spine. Get your assistant to grab the top of the drape, your hands should be folded under the drape to prevent contaminating yourself.
- Sit down and get comfortable. Adjust the bed height if necessary so you can reach the patient without having to bend too far. Now draw up your drugs. Use different sized syringes to draw up your skin local and your spinal drugs. I use a 2ml for the skin and a 5ml for the spinal. Lots of people do the opposite. This makes no sense to me as you only need a ml or two to make a skin bleb and often you want to put more than a couple of mls in your spinal. Draw the skin local up first with a blunt needle. Then draw up your spinal- usually you'll be using heavy Marcain (bupivacaine). Check the ampoule and shake it vigorously to mix the dextrose with the local (preventing drawing a dextrose rich sample) and ward off bad spirits. Draw up more Marcain with the blunt needle than you need then flick the syringe a couple of times to get the air bubbles to the top then squeeze out the Marcain until you have the desired dose. The dose will be somewhere between 2 and 3 mls- the bigger the dose the longer it lasts. This is the single most important factor that determines how long your spinal will last. If you are using fentanyl (which probably doesn't contribute anything meaningful to your anaesthetic) draw this up with an insulin syringe after checking the ampoule with your assistant as it isn't in a sterile package. Again draw up more than you need, flick it and squeeze the plunger until fentanyl is coming out. Pull back the plunger on your spinal drug syringe to make room and then put your desired dose of fentanyl (it makes no difference really) in. Filter needles are not necessary and I don't use them as they don't contribute anything useful and are a sharps hazard. Slide the introducer needle off the spinal needle and lay everything out in the order that you will use them.
- By now the prep will have dried on the patient's back which is what you want. Warn the patient that you are going to feel around their hips and press on their back. Then identify the intercrystal line which runs through the top of the iliac crests. You will have to press

firmly in obese patients to identify this. The intercrystal line only runs through the L3/4 interspace half of the time. Next try and identify the midline and feel for spinous processes. Get them into their best 'pushing my fingers away from your back position' as described above. I go for the best feeling lowermost space. You never want to put a spinal in above L1 because of the risk of injecting into the spinal cord. The cord 'ends' at L1 level in adults if they've read the textbook. I would only go one space above the intercrystal line and even then there is a reasonable chance I'm at the L1/2 interspace. Being off the midline is the core issue in most 'difficult' spinals. If it is hard to feel anything look for where the bum crack, sorry natal cleft is and feel up on the thoracic spine which is usually easier to feel in obese patients. Ultrasound can be used to identify the space. Don't spend all day cruelly sticking your thumbnail in the patient's back. Choose a spot and go with it. If you want to 'mark' the spot I recommend using the hub of the cap of a needle and indenting the skin with that. Don't draw on patients, the prep will remove it anyway and there is a risk of tattooing if your needle goes through the ink.

- Now get the skin local, warn the patient of a big scratch (not "a little scratch") and inject a healthy skin bleb by injecting at your chosen point with the needle parallel to the floor- don't fan up and down unless you're a sadist. This stuff stings like blazes and you need to talk the patient through it- the initial burning will subside. Then insert the needle to the hub but don't inject any more local. This is just to confirm that you aren't over a spinous process. You are using the needle as a seeker and if you hit bone then you need to find a new spot and inject another bleb there. Injecting local deep just hurts. Then lay your syringe down to the side and do not recap it! **Never recap a needle.** Local takes some time to work so I often flick the bubbles out of my spinal syringe; pick up a gauze square to dab the back; ask the patient where they live or some other inanity then I pick up the introducer needle.
- Warn the patient of pressure in their back- they are always aware of the introducer needle going in. Insert it parallel to the floor and all the way to the hub (unless they're a 45kg ballerina). If you hit bone, pick a new spot. Next get your spinal needle. Most of the time it will be a 25g pencil point. Insert it inside the introducer, I grip the needle about half way along as I insert it to prevent it bending. Then insert the needle steadily and smoothly until you feel a pop or change in resistance. The subarachnoid space is between 5 and 7cm deep in the majority of people. When you feel a change or have inserted a fair amount of needle remove the stylet and see if CSF flows out. If not advance further and check again. If the patient complains of pain, stop and see if it resolves. If they have persisting pain you must always remove the needle. It can be useful to ask where the pain is- radicular pain and pain to one side suggests you are off the midline and you should remove the needle. Not uncommonly patients will get a transient paraesthesia as you traverse the dura. This should quickly resolve however. If you get CSF coming back allow a few drops to drip out to ensure there is no air in the needle hub. Now place the back of your non-dominant hand against the patient's back and grip the spinal needle between your thumb and forefinger. With the spinal syringe in your dominant hand twist it securely onto the hub of the spinal needle. Gently pull back on the plunger to aspirate CSF and see the 'oil on water' effect as it mixes with the local. (You don't get this with plain Marcain as they are of similar baricity.) If you can't aspirate then remove the syringe to ensure CSF is still flowing out. If it is then reconnect the syringe and inject. The injection should be painless; if not you

must stop. When you've injected half of the spinal drug aspirate again to confirm you are still in the subarachnoid space. If you can't, remove the syringe to confirm flow again. When you've injected it all remove the needle, place it on your trolley and place a dressing on the back and lie the patient down.

- If you hit bone, which is unmistakable, stop, remove the needle and re-evaluate. You have to change something or you will have the same problem. Change one thing at a time.

You always have only these six options:

1. Go up a bit (finger's width)- you may be near the bottom of the interspace and are hitting a spinous process.
 2. Go down a bit- you may be near the top of an interspace.
 3. Go to one side a bit (this is the paramedian approach)- you are off the midline or the interspinous ligament is calcified and prevents a midline approach.
 4. Angle your approach a bit- try and avoid acute angulation as it makes your target smaller and further away (like the hypotenuse of a triangle).
 5. Try another interspace- don't go more than one space above the intercrystal line.
 6. Improve/ re-establish the patient's position.
- Generally I would check position again (usually roll them forward as they've slumped back) and angle up a bit. If you keep hitting bone it invariably is because you're off the midline. Sometimes you just have to pick going to one side and try that. If using a paramedian approach you don't need to angle the needle in the sagittal plane much at all otherwise you end up hitting lamina on the other side.
 - If you are still struggling and have tried another space stop and get help. Your patient will be enjoying it less than you are. Experience makes all the difference. A standard spinal needle is 9cm long. Even in morbidly obese patients a long needle (12cm) is rarely required.
 - Other options to be considered are:
 - Trying in lateral position (see below)
 - Using a larger needle- stiffer, has better 'feel'.
 - Do a CSE- again better feel with a thick needle but no good if you prang the dura with it.
 - Ultrasound guidance- requires practice.
 - Abandoning the procedure- tormenting the patient and further delaying the surgeon won't help the cause.
 - Once you've done your spinal and the patient is laid down dispose of your sharps- this is your responsibility. Then assess the patient: feel their pulse and check their colour as vasovagals are common. The spinal will take a few minutes to kick in. The first BP post spinal is usually fine, it is the next one that is often low. Treat hypotension aggressively with vasopressors, not fluid. Finally you need to evaluate your block. You must do this before letting the surgeon at them. My routine is check the BP (a drop is heartening) and then check for motor block first. Expose their feet, hold my finger well above their foot and ask them to lift each leg in turn. They should just be able to roll their leg a bit- if there is no appreciable motor block then your block is no good. Don't ask the patient to wiggle their toes because they will be able to do that! (The L5/S1 nerve root is the largest and takes longest for local anaesthetic to penetrate.) If there is not much motor block, wait a few minutes and repeat. Next assess sensory blockade. Most people use ice. Place icepack

on patient's arm to demonstrate how darned cold it is and then ask them to tell you when it feels cold like that when you place it on their body. I start on the upper thigh and slowly slide it up their abdomen until they say it is cold. Don't dab or bounce the icepack as they will feel the pressure sensation. When they say it is cold I continue up further until they say it is *really* cold! This is the threshold you are looking for, not the transition zone. Repeat on the other side. Generally you should expect to have a block in the high to mid-thoracic dermatome. T4 is nipple level (in males anyway), T1 axilla, T2 sternomanubrial junction, T8 xiphisternum. If the block is high ask if they have tingling in their little finger (C8-T1). It is almost impossible to have a total spinal with a standard dose spinal- the only exception may be if you've got your patient in steep trendelenburg position. Remember temperature sensation, sympathetic fibres and pain are the modalities blocked before motor fibres. If you are not sure you can test for light touch with the hub of a needle cap or gently pinch with tweezers. Usually it is clear- if they can't move their legs you're on a winner.

The lateral position

A few words- this is commonly used for the patient with a fractured limb or painful condition that makes sitting difficult. It is generally easier for patients to lie on their side than sit up if they are in pain or distress. It also helps stabilize the patient who may lean or sway otherwise. (Patients are less likely to have a vasovagal when lying flat.)

- Generally a degree of sedation/ analgesia is required to facilitate turning the patient onto their side so appropriate monitoring and supplemental oxygen must be in use.
- Normally put the patient with the bad side up- this means they're not lying on it while you do the block and you don't have to change position again after performing the block.
- Have the patient near the edge of the bed so you don't have to reach too far over. Bending their hips and knees doesn't change much but hurts so don't bother with this. Ensure their back is perpendicular to the floor by rolling them into position.
- Insert your needle parallel to the floor, it is easy to be at an angle and miss your target.
- Plain marcain is a good option in this position as it is slightly hypobaric and will tend to drift up. (Heavy marcain is fine too but you have to turn the patient if the bad side is up.)
- Elderly #NOF patients often have extensive midline calcification and spondylosis and the paramedian approach is a necessity. Go one finger across and toward the bottom of a space and angle slightly cephalad. Try and keep parallel to the floor still.

Epidural

This skill has added layers of complexity unlike a spinal which is essentially a lumbar puncture. Epidurals have a longer list of potential complications; they have a higher failure rate and are technically more demanding. The benefits of an epidural are they provide excellent quality postoperative analgesia for up to several days, they can provide long lasting surgical anaesthesia and there is some evidence that when used in combination with a GA for major intra-abdominal and intra-thoracic surgery there is a decreased incidence of adverse respiratory events.

The standard Tuohy needle is 8cm long and has 1cm markings commencing at 3cm. Most people use a 18g or 16g needle. These needles have a slightly different 'feel'.

All the above considerations described for spinals apply for epidurals with regard to monitoring, positioning, prepping and putting local in the skin. I believe epidurals are best learnt under direct supervision with an engaged teacher (both of you scrubbed) doing the real thing on at least half a dozen patients and more if struggling.

Some notes re specific technical considerations for epidurals:

- Be generous with your skin infiltration- 10mls of 1% lignocaine is not unreasonable. Big needle, big pain. Give it time to work (get your other bits and pieces ready).
- Use a sharp 18g needle to make a skin nick before inserting the epidural needle- the Tuohy is relatively blunt and as well as being difficult to insert through the skin which hurts the patient you can embed a core of epidermis and create a cyst.
- I recommend learning to find loss of resistance (LOR) to saline with a constant pressure technique. LOR is quite distinct and can't be explained in a book. You must experience it for yourself. Don't apply the LOR syringe until you're past the interspinous ligament.
- If the catheter doesn't feed easily you're in the wrong place.
- Invariably when you thread the catheter patients experience pain/paraesthesia/tingling- warn them of this and this should be transient only.
- If blood tracks up your catheter pull it out, get a new kit and do it again. You can use the same interspace.
- Know beforehand what to do if you get a dural puncture. It is easy to recognize! If you are not sure pull everything out and ask for help.
- Never inject more than a spinal equivalent dose of drug down an epidural catheter. Always aspirate before you inject.
- Never twist the Tuohy when you've inserted it.
- Before you do your first thoracic epidural look at a model of the spine closely and appreciate how the interspace is narrower and the spinous processes slope back caudally. There is less space between the thoracic epidural space and the spinal cord.

There are further notes relating to obstetric epidurals in the *Obstetric Anaesthesia* chapter.

Combined Spinal Epidural, CSE

The supposed advantage of this technique is the reliability of a spinal combined with the potential for prolonged neuraxial anaesthesia and more commonly postoperative analgesia. Most people used a dedicated combined kit- LOR is found with an epidural needle and then the spinal needle is passed through the epidural needle to locate the subarachnoid space. The epidural catheter is then fed after injecting the spinal component. There is a high incidence of paraesthesiae and a higher failure rate of the spinal component. The potential complications of both techniques are implicated. The epidural is 'untested' and it is difficult to determine when to top up the epidural in the event of prolonged anaesthesia being necessary. (I am not a fan of this technique you might reasonably guess.) Its main benefit is as a means of teaching both neuraxial techniques simultaneously!

CHALLENGE QUESTIONS

1. You have performed a technically pristine spinal but have got no block as a result. What are some causes of this and what should you do now?
2. What are some ways to achieve a long lasting spinal anaesthetic?
3. Why does even the crappiest epidural usually afford a degree of analgesia?

ANSWERS

1. This has happened to us all. If it hasn't happened to you yet it is because you haven't done enough spinals. Causes of a failed block are many and can be classified into three main groups: didn't inject drug into subarachnoid space; didn't inject correct drug (eg digoxin) and drug didn't spread properly. The reason often given by the anaesthetist involved that it was a dud batch of marcain has never been substantiated to my knowledge. The first reason is the commonest cause. I have seen many a registrar stick their introducer needle in to see clear fluid dripping out and then proceed to attempt to inject their spinal drugs. Of course they have just found a well of local anaesthetic that they injected a minute earlier. The books talk about curious out-pocketings in the subarachnoid space called Tarlov's cysts and speculate that if you inject into these thin necked cysts that the local won't diffuse. I think it is all nonsense. In the event of having a completely failed block it is reasonable to try again and usually it works fine (because you injected the stuff in the correct place!). In the event of a partial block your options include: wait for block to completely resolve and do it again; convert to GA; do an epidural and titrate it to desired level of block.
2. The main factor that determines the duration of a 'standard' spinal anaesthetic is the dose of local anaesthetic. The upper limit dose for me is about 3mls of bupivacaine. A spinal amp contains 4mls but I have never injected that much for fear of a high spinal at the least. There are a host of adjuvant drugs that have been added to local anaesthetics to prolong their action including weird things like neostigmine and midazolam. Although they work I wouldn't consider them part of conventional practice. The adjuvant that has a large body of clinical experience behind it is clonidine. Only a small dose is needed, about 30mcg, or one fifth of a 150mcg ampoule. This will reliably prolong your block by a good hour or two but also means that your patient requires vasopressor support for the duration. Note that intrathecal morphine will give you prolonged analgesia but not anaesthesia. The other option which is very effective but uncommonly performed deliberately is to use an intrathecal catheter. This is most commonly an epidural catheter inserted after an intended or, more commonly, an unintended dural puncture with a Tuohy needle.
3. Invariably the epidural solution contains fentanyl, usually 2mcg/ml. The pharmacokinetics of epidural and intravenous fentanyl are virtually indistinguishable. If the epidural rate has been cranked up to 15mls an hour then they are effectively receiving a fentanyl infusion of 30mcg an hour which is better than nothing.

LIGHT RELIEF

THINGS THAT CAN GO WRONG WITH AN EPIDURAL

All of the following adverse consequences associated with epidural blockade have been documented in the literature. They are vaguely listed in order in terms of morbidity:

Rash precipitated by antiseptic skin preparation solution
Skin reaction to dressings placed over catheter
Bruising at needle insertion site
Nausea
Dyspnoea
Pruritus
Vomiting
Shivering
Hypotension
Bradycardia
Vasovagal episode in onlooking personnel
Vasovagal episode in patient
Exacerbation of lower back pain
Mallory Weiss tear from forceful vomiting
Skin burn from electrocautery use igniting skin prep used for epidural
Dural puncture recognized immediately
Dural puncture presenting with cranial nerve palsy
Dural puncture unrecognized presenting late with intracranial haemorrhage
Failure of blockade
Patchy block
Lopsided block
Unilateral block
Fall due to weakness or proprioceptive loss
Hypothermia
Horner's syndrome
Urinary retention
Tinnitus
Motor blockade
Respiratory depression
Venous air embolism
Superficial infection
Osteitis
Osteomyelitis
Iliopsoas abscess
Neurotoxicity from inadvertent intravascular injection LA
Cardiotoxicity from inadvertent intravascular injection of LA
Priapism
Myoclonus

Coronary artery spasm
Worsening of pre-existing neurological disease
Epidermoid tumour from introduction of dermal tissue
Subdural placement of catheter
Intrathecal placement of catheter
Total spinal
Duro-cutaneous fistula
Difficulty removing catheter because of knot in catheter in epidural space
Retention of catheter fragment in epidural space due to breakage on attempted removal
Inadvertent injection of drug not intended for epidural administration, for example metaraminol, pancuronium, cephalothin and suxamethonium
Pneumocephalus
Subcutaneous emphysema
Persistent hiccups
Retroperitoneal air
Interpleural placement
Pneumothorax
Epidural venous thrombosis
Cord damage (syrinx) from direct trauma from Tuohy needle
Meningitis
Adhesive arachnoiditis
Meningo-encephalitis
Nerve root damage- transient
Nerve root damage permanent
Cauda equina syndrome
Cardiac arrest
Spinal cord infarction related to hypotension and decreased cord perfusion
Epidural abscess
Epidural haematoma
Paraplegia
Quadriplegia
Death

Everything you should know about Propofol TCI

Every practising anaesthetist should know how to program a pump for propofol TCI to facilitate TIVA. They should also be familiar with the differences between the programming model options the pump provides as well as have a plan to manage the morbidly obese patient. I say 'should' because it is clear to me that most people struggle beyond being able to program the pump for a non obese patient. This is especially remarkable considering many practitioners use propofol TIVA as their mainstay technique. Knowledge of the difference between the Marsh and Schnider models and their practical implications is almost nonexistent amongst trainees. The consideration of effect site versus plasma concentration targets is a further degree of complexity that eludes many yet I would consider this core knowledge especially if you are about to sit the Primary Examination. Finally what to do with a morbidly obese patient is similarly confusing especially when current pumps will not accept the actual parameters of a morbidly obese patient (this is for good reason as we will discover). The fact that all the 'standard' and 'popular' texts do not address this topic does not help the cause. So in an effort to rectify this knowledge deficit I have composed this brief primer. Some knowledge of basic infusion pharmacokinetics is assumed and this was briefly discussed in the Propofol chapter.

Propofol TCI (Target Controlled Infusion) refers to programming a pump loaded with a software program designed to deliver an infusion that is predicted to produce the desired target concentrations you have input into the pump. The software consists of incorporating

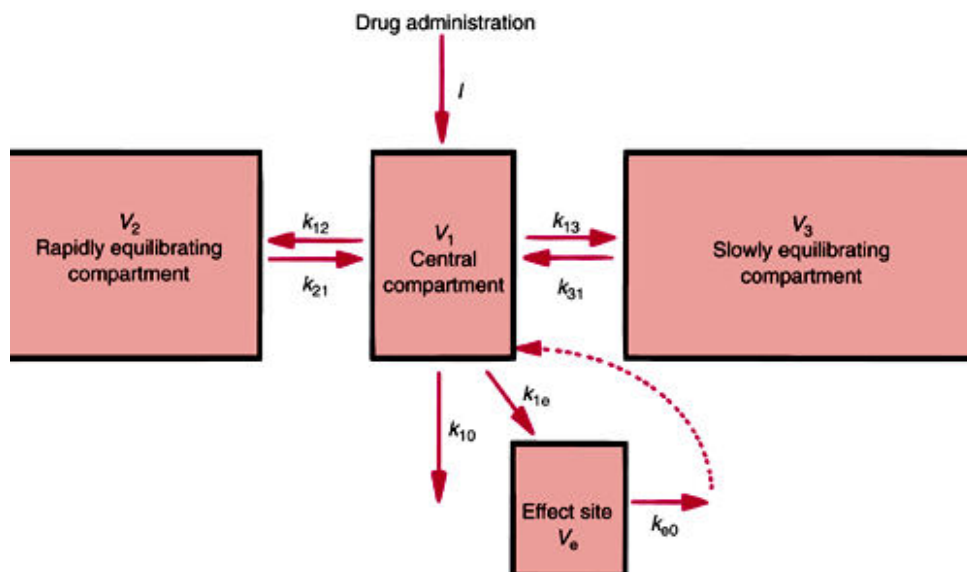

pharmacokinetic parameters into a mathematical algorithm. The pharmacokinetic model is based on a tri-compartmental model as depicted above, incorporating an initial loading dose compartment, V_1 , roughly approximating to the intravascular space and two other compartments- a fast V_2 and slowly equilibrating V_3 compartment to approximate the vessel rich group and adipose tissues respectively. Elimination is conceptually determined to be occurring from V_1 only. To enable effect site targeting a further virtual compartment, the effect site, V_e is added with an equilibration constant, k_{1e} . Conceptually no significant drug mass is

delivered or eliminated from the effect site. The effect site allows incorporation of the pharmacodynamic aspect of TCI. The algorithms operate by delivering a bolus dose on induction followed by two simultaneous infusions once the target has been reached- one exponentially declining infusion to account for maintenance of blood concentrations with redistribution of the drug from V_1 to V_2 and V_3 and another constant infusion to account for losses of drug via elimination. This algorithm is known as the BET method: Bolus, Elimination and Transfer. It is generally accepted that these algorithms are superior to manually calculated regimens that were used to achieve the same outcome- provide safe intravenous anaesthesia using propofol. The best known manual method is the Bristol regimen which consisted of a 1.5mg/kg bolus for induction followed by an infusion of 10mg/kg/hr for ten minutes then 8mg/kg/hr for the next ten minutes and then 6mg/kg/hr thereafter. This is designed to equate with a plasma propofol concentration of 3mcg/ml.¹

In Australasia there are two propofol TCI models to choose from- Marsh and Schnider. Both have the option of using either plasma or effect site concentration targeting but not all pumps have both these options. Both Marsh and Schnider were devised using a very small sample population with a very limited range of physiological parameters. Astonishingly Marsh had only 18 subjects (ASA 1-2 and normal BMI and not elderly) and Schnider had 24 subjects! Despite this they are employed for thousands of patients with all manner of co-morbidities undergoing all manner of procedures on a daily basis! Both models are quite different and have clinically important implications for the anaesthetist. Let's consider them in detail.

The Marsh model (aka Diprifusor model as it was marketed with a specific pump initially that used dedicated Diprivan cartridges) was first available in a closed system in 1997 in Australia. It requires two parameters to be input: weight and age. However only one of these parameters actually changes the dose delivered, namely weight. The age parameter is simply to prevent the pump operating if an age less than 16 was input as it wasn't licensed for paediatric use. In the Marsh model all the compartment volumes (V_1 - V_3) are proportional to weight whereas the rate constants are fixed. Clearance is fixed at 27mls/kg/min from V_1 .

Schnider is a more complex model and intuitively sounds like the superior model to use. It requires several more parameters to be input, namely: weight, age, height and gender. Notably all these parameters do account for dose adjustments in the algorithm unlike Marsh. V_1 and V_3 are fixed. V_2 and transfer constants into and out of this compartment vary with age. Clearance varies with weight, height and lean body mass (LBM). Gender alters the calculated LBM.

Let's consider the equation for clearance:

$$\text{Clearance}(k_{10}) = 0.443 + 0.0107(\text{Weight}-77) - 0.0159(\text{LBM}-59) + 0.0062(\text{Height}-177)$$

The reason I have reproduced this unpalatable equation is to help you appreciate that all the parameters input into the Schnider TCI lead to changes in this equation which is the principal cause of differences in the maintenance infusion rates produced. Increasing weight and tall subjects will generate larger clearances and this is offset by increasing LBM *to a degree*.

Yet there are some bizarre aspects to the model- the most notable one being that the initial compartment, V_1 , is not just fixed but has a very small value of 4.27 litres. This means that if

you choose plasma concentration targeting for your TCI using Schnider it won't actually put your patient to sleep. This is because the loading (induction dose) is calculated by multiplying V_1 by the target concentration. If you chose $3\mu\text{g}/\text{ml}$, you get $4.27 \times 3 = 13\text{mg} = \underline{1.3\text{mls}}$ of propofol! Consequently you shouldn't ever use plasma TCI with Schnider unless you are just sedating someone and are very patient. Using Schnider in effect site mode gets around the problem because to reach an effect site target it has to *overpressure* the bolus dose in. This is analogous to a volatile induction- the initial vaporizer setting is way above the desired target.

Consider the bold red and green curves on the diagram below. These illustrate the plasma and effect site concentrations that are generated for a TCI aiming for a target concentration of $2\text{mcg}/\text{ml}$ using the Marsh model. Note that the peak plasma concentration (bold red) is almost three times that of the effect site (bold green) concentration. Hysteresis is evident in the curves which is incurred by the lag period as the drug traverses the blood brain barrier to reach the effect site. There is a delay in the rise of the effect site concentration compared to the plasma concentration until they cross each other at the 5 minute mark. Then the effect site concentration remains above the plasma concentration until they equilibrate. Consequently, if an effect site is targeted, the pump will always generate a considerably higher plasma concentration to achieve this effect target than if a plasma target is selected. The thin red and green lines show what the plasma (red) and effect site (green) curves look like if a faster (larger value) effect site equilibration constant is incorporated into the model (this is what is done in the 'Modified Marsh' model). There is less overshoot, a smaller peak plasma concentration is generated, and the effect site target is achieved slightly sooner at one minute as opposed to two. Equilibrium is achieved earlier as well.

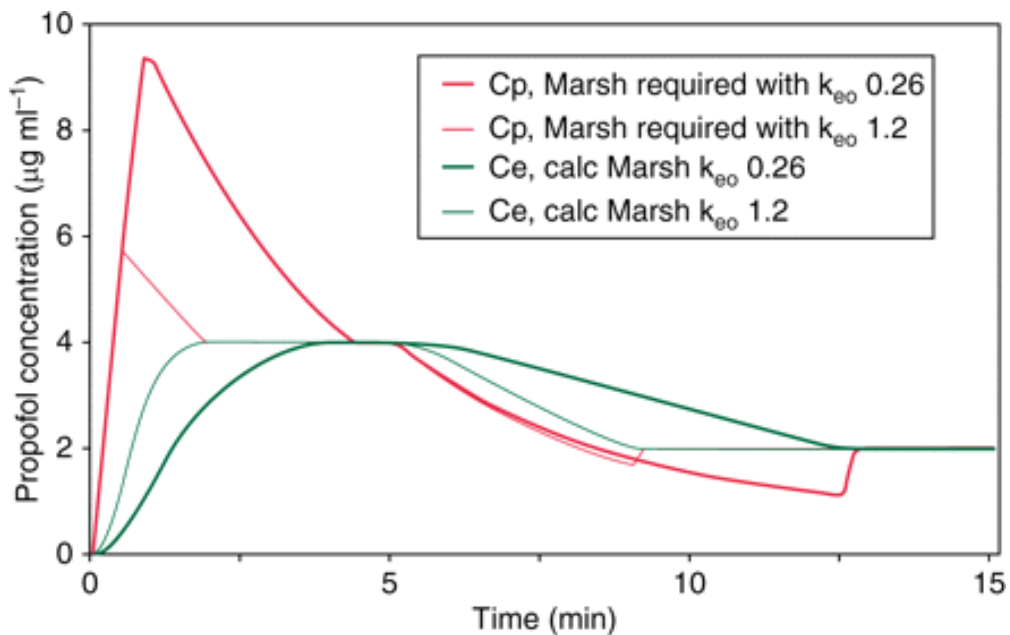

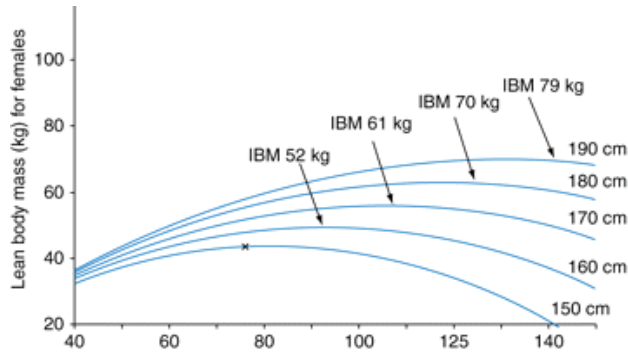

The other problematic feature which is shared by the Minto algorithm for remifentanyl TCI is that the calculation used to calculate lean body mass (LBM), the James equation², in fact describes an inverted parabola. This means for very obese subjects the LBM calculated is paradoxically and incorrectly low. This is demonstrated on the diagram above which charts LBM against actual bodyweight for patients of varying heights. A series of curves that arch downwards are depicted. At extremes it will generate negative values!! LBM is incorporated into the calculation of clearance in the Schnider model equation reproduced above and (incorrectly) small values for LBM generate inappropriately high values for clearance and consequently inappropriately high infusion rates to maintain plasma concentrations. Incidentally it has the opposite effect in the Minto program and inappropriately low values for clearance are calculated. (Incidentally Charles Minto is an Australian anaesthetist who lives in Sydney.) This has required the pump manufacturers to incorporate a 'fix' for this problem- *they simply don't allow you to input values that would generate a BMI beyond the peak of the parabolas*. This is a BMI of 43 in men and 37 in women. This immediately excludes a large proportion of my caseload, pun intended. We will consider what to do with morbidly obese patients later.

Let's compare Marsh C_p and Schnider C_e then. If you program the same numbers into the pump (i.e. target of $3\mu\text{g}$ and same weight of 70kg, default height and gender for Schnider) and start them up they will both put your patient to sleep but they will deliver different volumes of propofol and will generate quite different predicted effect site concentrations in the process. Most differences are evident in the first ten minutes as demonstrated in the figure below. Marsh will deliver a larger initial bolus and run at a higher maintenance rate than Schnider³ but will display a much lower effect site concentration despite the fact it has delivered more white stuff! This merely reflects the different k_{eo} 's used by each mode⁴- Marsh uses a smaller (hence more slowly equilibrating) value than Schnider- 0.26 vs 0.45. Both are probably generating nonsensical effect site values during the induction phase but this is immaterial as you are looking at your patient to determine whether you have reached your desired pharmacodynamic endpoint! If we restart the program but make our patient eighty years old Schnider will deliver an appropriately smaller bolus and maintenance infusion whereas Marsh is unchanged. If we restart it again inputting 100kg for each Marsh generates a significantly higher maintenance infusion rate. Schnider will consistently deliver more to a female vs male subject as a higher clearance is calculated due to a smaller LBM for women as per that unpalatable equation above. After 15 minutes both models will deliver similar infusion rates and so the infusion rate displayed on the pump at this stage is a useful one to resort to should your pump fail at this

uncture. For most subjects this is of no clinical consequence as we routinely overdose people during TIVA and this is probably a good thing.

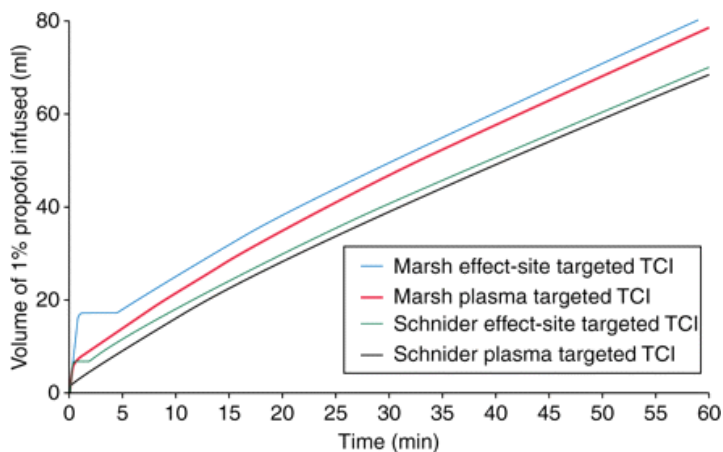

Above three diagrams are respectively Figures 2, 6 and 5 from A Absalom et al. Pharmacokinetic models for propofol-defining and illuminating the devil in the detail. *British Journal of Anaesthesia* 2009; 103: 26-37. Used with permission.

The correlation of predicted and actual plasma concentrations of propofol by the pump is quite poor but again probably not clinically important as you will be operating well above the C_{p50} for amnesia. The error is about 20% and gets worse the longer an infusion runs. The TIVA protagonists make the point that there is a similar degree of error between end-tidal and arterial volatile agent concentrations. I make the point that at least end-tidal volatile monitoring is measuring an actual value! All models tend to under predict the actual concentration during the recovery phase. If your patient is less likely to cope with our routine propofol overdose then using the Schnider model may be advantageous as it delivers less and at a slower rate than Marsh. It will also 'correctly' give less to an elderly subject whereas age doesn't change the Marsh algorithm.

Okay what about our obese patients? Short answer is you shouldn't TIVA them- just use Desflurane. But there's no pleasing some people. LBM is the most appropriate dosing scalar to use to calculate induction dosing whereas total bodyweight is more appropriate for maintenance requirements. LBM increases relatively linearly with total body weight up to a BMI of around 45 at which point it plateaus. This is designated an allometric (non linear) relationship. See *The Obese Patient*. So although the absolute dose requirements of the morbidly obese patient exceed those of the non obese there is not a direct relationship between LBM and total bodyweight. The problem with the existing models are: Marsh has the input weight capped at 150kg and will overdose on induction (linear relationship between weight and size of compartments in the model) yet doesn't deliver adequate maintenance infusion rates in the morbidly obese patient as clearance and transfer constants are fixed. Schnider simply doesn't let you input figures that would result in a BMI beyond the relatively modest capped values. One recommended approach is to induce with a dose based on the patient's LBM and then run a manually controlled infusion, Bristol style. It would probably be prudent to slap a BIS⁵ on too in this instance as it is all an educated guess at best.

But say you want to use your beloved pump- a proposed solution by La Colla⁶ et al that I have grossly simplified is to input a *fictitious height* into the Schnider pump. This height lets you input the patient's actual weight and will equate to the maximal BMI the pump will allow to be programmed into it. For example a man weighing 150kg, the fictitious height = $\sqrt{150/42.9} = 1.87\text{m} = 187\text{cm}$. The maximum height you can enter is 220cm and my system works up to a weight of 200kg in a male. So even this has its limitations, not the least being it is absolutely not recommended or validated by anyone! It possibly is overdosing a little in the maintenance phase because the fictitious increased height leads to an increased clearance value being calculated. Some number crunching: below are the actual induction doses and initial maintenance infusion rates for various scenarios for a 150kg male when programmed into an Alaris pump. The target (plasma or effect site) is 3.0 mcg/ml in all the examples and the age is forty. Note the paltry 'induction' dose with Schnider plasma TCI.

Model	Bodyweight (kg)	Height (cm)	Induction dose (mls)	Maintenance rate (ml/hr)
Marsh	150	(187)	12.4	164
Schnider_p	150	187	1.4	113
Schnider_e	150	187	12.8	102
Schnider_e	150*(131)	175	10.7	94.5

*For this height the maximum weight that can actually be input for a male is 131kg. Note how similar the induction doses are yet Marsh has a much higher maintenance rate as it just scales the size of the compartments in a linear, not an allometric, fashion.

The future is promising. Other algorithms have and are being developed using larger population sets and a wider range of parameters. There have been calculations devised that accurately calculate LBM for morbidly obese patients, these are the Janmahasatian⁷ equations, and surely these will be incorporated into future models if not into the existing Schnider and Minto models. The Marsh model is available on other pumps with a faster k_{eo} of 1.2 (the modified Marsh model) which causes less overshoot and less overdose on induction as described earlier. A recent study by Cortinez involved collecting data from 20 obese patients (BMI 35-52) receiving propofol TCI and then comparing actual values with those predicted by 5 different TCI models including Marsh and Schnider. All the models were pretty poor and all tended to underestimate actual concentrations- not a bad thing. They then incorporated an adjusted bodyweight (ABW) into the Marsh and Schnider models and reported that these performed very well indeed! Unfortunately the formula used to calculate ABW⁸ is very cumbersome indeed and the study sample is small in number. Feedback loop systems incorporating BIS (shudder) and measuring exhaled propofol concentrations are promising areas of development. One thing I know for sure is that our patients are not getting any smaller.

1 McFarlan et al devised a paediatric manual regimen to maintain the same target of 3mcg/ml. It consists of a LD 2.5mg/kg then 15mg/kg/hr for 1st 15 mins then 13mg/kg/hr for next 15 then 11mg/kg/hr for next 30mins then 10mg/kg/hr for next hour then 9mg/kg/hr for subsequent two hours.

2 The James equations are hideously complex: $LBM_{men} = 1.1 \times TBW - 128x (TBW/Ht)^2$

3 This is the simple explanation- it depends on which pump you have, for the Alaris PK in Schnider effect targeting mode it will calculate an individualised k_{eo} for each patient to equate with a t_{peak} of 1.6 minutes. This will invariably be a larger (& faster) k_{eo} than Marsh.

4 In effect site targeting mode the systems over-pressure the propofol in - Marsh in effect site targeting mode will deliver more than Schnider. This mode is not available on the Alaris PK pump at present.

5 BIS still really doesn't have anything to offer in this scenario except to confirm that your drip is connected to the patient.

6 La Colla corrected the James equations to the Janmahasatian equations using the following formula for 'fictitious height', $FH_{men} = (9.27 \times 10^3 \times TBW) / (6.68 \times 10^3 + 216 \times BMI)$. They then validated these values using the Minto model for remifentanyl in morbidly obese subjects. Kudos to them.

7 These are even more complex than the James equations so will definitely need to be incorporated into a pump! Janmahasatian is Australian and used absorptiometry on a large data set of obese patients.

8 For a male $ABW = IBW + 0.4(TBW - IBW)$, where $IBW = 45.4 + 0.89[(Ht - 152.4) + 4.5]$

SELECTED REFERENCES

Absalom et al., Pharmacokinetic models for propofol- defining and illuminating the devil in the detail. *British Journal of Anaesthesia* 2009; 103: 26-37.

A cumbersome but oft cited article delineating the differences between Marsh and Schnider and their shortcomings. It did contain errors which were addressed in subsequent correspondence.

La Colla et al. Pharmacokinetic model-driven remifentanyl administration in the morbidly obese: the 'critical weight' and the 'fictitious height', a possible solution to an unsolved problem? *Clinical Pharmacokinetics* 2009; 48: 397-8.

First study trying to incorporate corrected values for LBM into the Minto program using the Janmahasatian equations.

Gepts E et al. Disposition of propofol administered as constant rate intravenous infusions in humans. *Anesthesia and Analgesia* 1987; 66: 1256-63.

This model formed the basis for the Marsh model, below.

Marsh B et al. Pharmacokinetic model driven infusion of propofol in children. *British Journal of Anaesthesia* 1991; 67:41-8.

This paper describes the derivation of the Marsh model- for adults only!

Anderson K and Kenny G. Total intravenous anaesthesia. Series of 3 articles published in the RCOA Bulletin November 2002, January 2003 and May 2003.

Janmahasatian et al. Quantification of lean bodyweight. *Clinical Pharmacokinetics* 2005; 44:1051-65.

Original description of the equations for calculation of LBM in morbidly obese subjects.

Cortinez et al. Performance of Propofol Target-Controlled Infusion Models in the obese: Pharmacokinetic and Pharmacodynamic Analysis. *Anesthesia and Analgesia* 2014; 119: 302-310.

A comparison of 5 models with actual data in an obese population set.

CHALLENGE QUESTION

How do you do TIVA for a child?

ANSWER

There are three options. If you are lucky enough to have a paediatric TCI program on your pump like Paedfusor or Kataria (both available for Alaris pumps) then you can use them. There is very limited published evidence to validate these studies although they have been used extensively in the UK. These models are probably not suitable for very young (<3 years) or small (<10kg) children.

Most of us won't have this option though and will need to use a manual regimen or program your pump with an adult algorithm with an appropriate fudge factor. The saving grace is most children are healthy and will tolerate a relative overdose of propofol without adverse effect. The paediatric manual regimen was described in the fine print in the preceding chapter. For a plasma target of 3mcg/ml, give a loading dose of 2.5mg/kg followed by 15mg/kg for the first 15 mins then 13mg/kg for next 15 min then 11mg/kg for thirty min and then 10mg/kg for an hour. This was validated in children aged between three and eleven.

The minimum weight you can input into the pumps is 30kg and of course they aren't validated for paediatric use. I personally would input the actual weight if I could otherwise select the minimum and choose a generous target. You could use BIS, there are dedicated paediatric electrodes available, but I believe it doesn't change what I would do. This is because you are invariably delivering a relative overdose. You could also use ketamine but I won't go there.

Of course the hardest aspect of paediatric TIVA is inserting the drip.

Putting it all together- Example Cases

Case 1- Orthopaedic washout/ DPC/ simple ORIF of Upper Limb

Preoperative

- You will do a lot of these cases during your training time. They need to be done well- these are generally well people who are working and you want to promote their recovery.
- Usual assessment- won't have been seen in PAC! For any trauma case, even a minor one, enquire about the mechanism of injury and whether there are any other injuries. Ask specifically about head and chest injury. Document assessment so that someone else can read it and get adequate information for a handover from it (the litmus test).
- Check baseline observations, airway, fasting status (it usually has been unnecessarily prolonged).
- Bloods- they don't need any. If someone has ordered them then look at them.
- Antibiotics- will invariably already be on them so check if due for another dose and give it before the tourniquet is inflated. Inject your cephalosporin slowly otherwise it will sting and make your patient nauseated before you've even started.
- IV- make sure it isn't on the operative side (duh!) and there is an antireflux valve in the line.
- If they are a repeat trip to OT then look at previous record- this is your single best source of information.
- Plan- it will take twice as long as the orthopod tells you. You could do a block but it takes time, has to work well and doesn't manage tourniquet pain so GA is the go usually. LMA usually fine- if they are green, have been vomiting that day or major injury then ETT. If procedure involves digit only then a digital block is a great idea.

Intraoperative

- Assessment sheet on anaesthetic trolley to remind yourself of patient details when they do the final check.
- Start correct patient on AARK (if you work in Qld)
- Baseline monitoring, I prefer BP on arm not leg but beware this will interrupt drug administration when inflated so I turn off after baseline reading and back on again after induction and settled.
- Standard induction- young robust males need generous induction doses so keep 2nd syringe of white stuff handy.
- Make sure antibiotic is in before the tourniquet is inflated, ideally ten minutes prior. Note on the record when this is up.
- If doing a digital block then do it now- don't use 0.2% ropivacaine, you want it to work. Then need less analgesic for case and won't forget it or have it done poorly by the surgeon at the end of the case.
- Stand back and scan everything- monitors and parameters all fine (NIBP cycling again), giving an anaesthetic (smelly on), can see patient's face (airway) easily. Can access IV line.
- Tourniquet issues:

- Pain- an awake patient will only tolerate this for 15-20 minutes. An anaesthetized subject will demonstrate a progressive rise in BP and HR from about the hour mark. As a rule you should never leave an arterial tourniquet inflated for more than two hours and preferably less than 90 minutes. The only effective management option of tourniquet pain is to deflate it. You should wait at least fifteen minutes before re-inflating it should you be stuck with Dr Slow.
- Deflation- anticipate the physiological effects of tourniquet release: fall in BP, rise in CO₂, often transient fall in SpO₂. Effects are more marked for longer tourniquet times, larger limb and presence of cardiorespiratory disease in the patient.
- Anticipate conclusion of case and get patient spontaneously breathing if not already. Weaning the respiratory rate is a waste of time- just take them off the ventilator and give occasional puff as you want their PaCO₂ to rise enough to trigger ventilation.
- At the end of the case don't turn off the smelly and lighten patient *until you have moved them back onto their trolley*. Transfers are stimulating!

Postoperative

- Cross out the panadeine forte and maxolon orders and chart appropriate postoperative medications and fluids if required.
- Handover patient and don't leave until 1st set of observations are done and okay.
- If they have a full POP cast applied it should be split before they leave recovery.

Case 2- Laparoscopic appendicectomy

Preoperative

- Usual assessment including considering whether they have appendicitis. A suggestive ultrasound has poor positive predictive value although many a case has been booked on these grounds alone. If the patient is afebrile, hungry, not particularly sore and looks well then they don't have appendicitis! If female and of child bearing age they should have had a pregnancy test.
- Bloods- don't need any but invariably have had some in the hope of demonstrating a raised WCC.
- Plan- acute abdomen so need intubation. If actually sick (i.e. have appendicitis) then rapid sequence is reasonable +/- sux. If airway looks okay then normal dose of roc and bagging with cricoid pressure on is a reasonable approach.
- Antibiotics- may already be on them in which case check they are not due for any otherwise will need some.
- IV- 20g is fine. Surgeon will want left arm tucked in so if IV on that side put on an extension or use line with a proximal injecting port.

Intraoperative

- Have assessment sheet on anaesthetic trolley to remind yourself of allergy status, ASA etc.
- Standard induction plus relaxant, cricoid if sick, been vomiting or other concerns about aspiration.

- Standard monitoring including NMT! (this is invariably forgotten)
- Auscultate post induction, secure tube, tuck arm in and ensure it is padded. Check drip runs okay when tucked in otherwise do what need to do to have a free-running drip.
- Suggest stick oximeter and NMT on right arm which is free- accessible and visible. NIBP will interrupt oximetry trace when it cycles but this is no drama and helps remind you to look at your patient every few minutes.
- If you used sux, don't give long acting until have objective evidence that the sux has worn off. Then give a reduced dose of NDMR- half the intubating dose or less.
- When they are prepping patient scan monitors and check you are giving an anaesthetic (smelly is on and around 1 MAC), all monitoring is okay and giving you pretty waveforms. Note what the airway pressure is and that have appropriate fresh gas flow of about a litre a minute once target MAC reached.
- Have an elbow over the patient's head and have this positioned quite low. A bar or high elbow will get in the way of the camera when it is swung around.
- Ventilation settings- suggest use volume controlled ventilation (VCV) for laparoscopic stuff and if using PEEP turn this on from the start. With VCV machine will try to deliver desired volume and with the pneumoperitoneum being applied will result in an increased airway pressure. This shouldn't be a problem unless the patient is obese or the tube is in the RMB or surgeon has ridiculous settings on the insufflator. If have pressure controlled ventilation (PCV) then tidal volumes will suffer as the pneumoperitoneum is applied.
- As they put the umbilical port in and establish the pneumoperitoneum keep a close eye on the haemodynamics. Be alert for a bradycardia heralding vagal stimulation from peritoneal traction. A marked drop in heart rate or severe bradycardia will need intervention- stop insufflating (disconnect gas), decompress the abdomen (port doesn't have to be removed), give anticholinergic, wait for things to normalize then let the surgeon recommence.
- As the pneumoperitoneum is established it will increase your airway pressures and end-tidal CO₂ will slowly rise. You don't need to increase ventilation volumes- just keep an eye on it.
- Check insufflator that the pressure setting is okay- should be between 10 and 15. A setting of 20 or more equates with no renal perfusion and not much venous return. You should know how to operate this machine- saves yourself five minutes of faffing about while the nurse/ orderly mucks around with it.
- Once surgeon is in they will want patient in Trendelenburg and tilted towards them a bit. This will further increase airway pressures.
- Be aware that the individual patient's haemodynamic response to a pneumoperitoneum is variable- some will get hypotensive as venous return is impaired, some will get hypertensive as resistance vessels are compressed in the abdomen and the rest won't change much. Just because your patient is hypertensive doesn't necessarily mean they are sore.
- Maintenance phase- give appropriate long acting analgesia and antiemetics. NSAID is good idea. Keep the patient paralysed, don't let them breathe for themselves against a pneumoperitoneum. Usually your induction dose of non-depolarizer is all you need.
- Emergence- extubate awake and on side as aspiration risk. Don't reverse until closing ports and determined that they are reversible! Don't wait until last minute to turn smelly

off or you will be waiting five more minutes with everyone looking at you. Generally turn off smelly as start on skin but leave on low FGF until dressings are applied.

Postoperative

- Usual postoperative orders, don't need PCA.

Case 3- Gynaecological laparoscopy

Preoperative

- Don't need bloods but pregnancy test if appropriate.
- Plan- will need ETT but may not take long. Suggest lowish dose (2/3) of Vec or Roc and wait extra minute before intubate. Dual agent antiemetic prophylaxis at a minimum. Need more than an ampoule of fentanyl for analgesia.
- Antibiotics are not indicated (but often asked for).
- IV- same as Case 2 as surgeon likely to tuck arms in.
- Expect to be a day case.

Intraoperative

- Similar to above- may not be able to use NMT properly until end of case when arm is freed.
- Considerations for pneumoperitoneum as above- many still use the evil Veress needle and will insufflate to a distressingly high pressure before inserting the trochar. You must ensure the pressure setting is reduced once they are 'in'. There is a higher incidence of bradycardia.
- Surgeon may want both arms tucked in which is a huge nuisance for you- check padding and that monitors are functioning.
- Usually remove head off bed as patient will be in lithotomy and then you don't have to move them as far down the bed.
- When move patient down bed don't disconnect from ventilator, just check that you have enough slack on the circuit and support the patient's head and the circuit (I usually clip it to the pillow) as move down. Disconnecting buys you two minutes of fiddling with the ventilator and meaningless end-tidal concentrations of your volatile agent.
- Don't forget to remove slide sheet if used otherwise the patient may slip during the procedure- this is disastrous.
- Patient is likely to be in steep Trendelenburg- this will markedly increase airway pressures and if the patient is obese will commonly cause desaturation due to the combination of hypoventilation and compression of dependent lung segments.
- If patient desaturates then institute your standard hypoxia drill to exclude anything else- scan monitors, manually ventilate, inspect and auscultate etc. If it is by exclusion attributed to Trendelenburg then can tweak ventilator settings, do alveolar recruitment manoeuvres and increase FIO₂. If still struggling then back off the Trendelenburg. Adequate oxygenation is the priority.
- Check arms particularly after any position change. If an arm is out on a board strap it on and be assiduous in checking it- a feeling of dread will ensue if you find an arm hanging down off the bed at an awkward angle at the end of the case.

- When finish scope- level out bed and make sure the scope light is on standby or off and the gas is off. An unprotected light lead will burn through the surgical drape in seconds (try it one day when no patient is in the vicinity and have a bowl of water to instantly extinguish it.)
- Often they do a D&C at the end so factor that into your timing.
- Routine reversal and wake up.

Case 4- Rapid Sequence Induction (RSI)

Indications

- Patient having GA at *significant* risk of aspiration:
 - Not fasted
 - Acute abdomen, especially bowel obstruction
 - Obtunded patient
 - Gastric stasis- pain/ opioids/ ESRF/ autonomic neuropathy
 - Significant symptomatic reflux esp. Waterbrash
 - Vomiting patient (or looks or feels like they will vomit)
 - Obstetrics (can be all of the above)

Preoperative

- Perform an airway assessment- if you suspect difficulty intubating the patient, reassess whether you should be doing this: ASK FOR SENIOR ADVICE.
- Consider giving antacid- Na citrate 30mls PO is probably the best as it can be given immediately prior. However, it alone may make the patient vomit. Oral or intravenous Ranitidine/ PPI takes 30-60 mins to have effect. Metoclopramide 10mg IV may have a brief prokinetic effect but this is of negligible benefit.
- Explain the procedure to the patient, esp. Cricoid pressure.
- If NGT in situ- aspirate it and leave it in. Consider inserting one in the patient with gut obstruction prior to induction if not already present.
- Prepare drugs and intubation equipment, check machine **esp. suction**- stylet in ETT. Have a low threshold for bringing the difficult intubation trolley into OT if the airway is not straight forward.
- Ensure your anaesthetic assistant is present, briefed and prepared.
- Establish secure IV access and apply all monitoring before starting.
- Position your patient optimally on the OT table, turn on suction and put sucker under pillow.
- Have Plan A and B for the airway clear in your head and communicated to your assistant. In effect this entails at a minimum having an appropriately sized 2nd generation supraglottic airway of your choice close to hand.

Conduct of RSI

- Preoxygenate the patient- 3mins by the clock with high flows and a well fitting mask, aim for ET O₂ >80%. If time is of the essence- 5 vital capacity breaths.
- Anaesthetic assistant places thumb and index finger over cricoid ring and applies 10 N (1kg) pressure.

- Generally speaking the use of sedatives or opioids are not warranted as they may obtund the patient and precipitate regurgitation before the airway is protected.
- A sleep dose of induction agent is given- some practitioners advocate giving a pre-defined dose but this may cause CVS collapse in an elderly/ septic/ sick pt.
- Assistant increases cricoid pressure to 30 N with loss of consciousness.
- Give Suxamethonium- at least 1mg/kg, ensure it is flushed in well.
- An alternative muscle relaxant for use in a so-called Modified RSI is Rocuronium 1mg/kg. (Note- Thiopentone and rocuronium precipitate if given together, a saline flush must be given between the two agents if used.)
- Intubate the patient after fasciculations have occurred or after 60s if using Roc or no fasciculations seen with sux; **don't** attempt mask ventilation while waiting.
- Cricoid pressure is not released until intra-tracheal ETT position is confirmed and you have told the assistant to release it. Auscultate in both axillae while you squeeze the bag and nowhere else.
- Don't forget to turn the smelly on! (Easy to forget as you didn't bag the patient.)
- In the event of failed intubation- follow a practised drill. Cricoid pressure may need to be reduced or released to facilitate oxygenation and ventilation of the patient.

Subsequent Management

- Use the nerve stimulator to confirm return of twitches prior to giving non-depolarizing muscle relaxant (excludes Scoline apnoea and guides use of NDMR).
- Give at most a half dose of NDMR otherwise you will have prolonged paralysis.
- Empty the patient's stomach again at the end of the case if a NGT is in situ.
- Extubate the patient awake- the highest risk period for aspiration is during extubation.

Case 5- The Sick Patient

Preoperative

- Sick patients get a general anaesthetic with an ETT (usually).
- Call your boss in.
- Clarify with the surgeon what their plan is- *this is vital information to enable you to plan the case.*
- Assess the patient carefully especially their airway.
- Are they on oxygen? What are their sats on room air?
- Check their bloods. Make sure you have a Group and Hold if there is to be bloodletting.
- Does the patient need to be resuscitated further before you inflict another insult on their physiological reserve?
- Organize the ICU bed *before* you put them to sleep.
- Make sure they have a decent drip. I recommend a dedicated line with a standard giving set with normal saline.
- Insert an arterial line. You will be glad you did this.
- Have vasopressor drawn up and ready.

Intraoperative

- A RSI is usually in order with the attendant considerations that were described in the previous case.
- Don't obtund the patient with midazolam.
- Don't give CNS depressants until the patient is on the table, monitored and being pre-oxygenated.
- Be cautious with fentanyl as opioids are sympatholytic and may precipitate hypotension and bradycardia as well as obtund the patient.
- It is a good idea to set your invasive pressure systolic alarm before you induce the patient. Avoid inducing them (if you can) until their heart rate is less than a hundred and their systolic exceeds this same value.
- Induce slowly with a drug that you are comfortable with. Start off with a quarter of the dose that you think you would normally use. Options include:
 - Propofol- careful now
 - Thiopentone- sometimes I make up a half strength solution
 - Ketamine
 - Ketofol
 - Etomidate
- Maintain your anaesthetic with opioid plus at least 0.5 age corrected MAC of volatile. Support the circulation as required to allow the administration of this anaesthetic.
- Don't forget antibiotics. Don't forget the IDC- best inserted at the *start* of the case.
- Don't forget to warm them.
- Send off a gas and FBE to see how your patient is going during the case.
- Don't extubate them unless you are confident that they will cope.
- Don't leave theatre for PACU until you have given them a couple of minutes to fall apart post extubation.

Special Situations



Obstetrics



Paediatrics

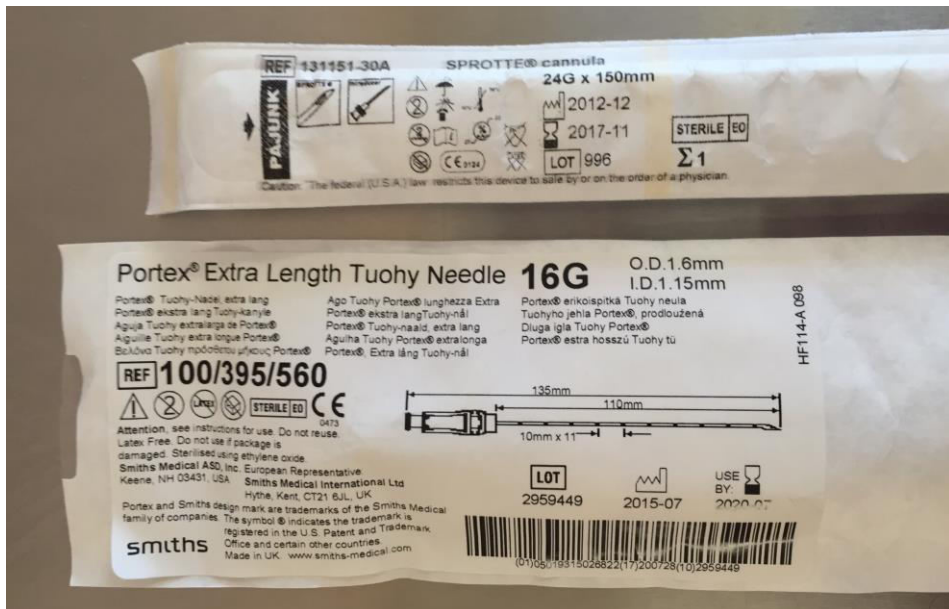

The morbidly obese patient

Obstetric Anaesthesia

Obstetricians think they are the only people in the hospital who require the services of the anaesthetist

It has been jokingly suggested that obstetric anaesthesia is just like regular anaesthesia except with left lateral tilt. Not quite. I will list some other notable differences that distinguish obstetric anaesthesia as a specialty field of practice.

- You are in the unenviable position of potentially being able to kill two healthy patients simultaneously with the one ‘mistake’.
- You are the only person in the theatre whose primary responsibility is the mother- you are her advocate. Better a dead baby than a dead mother- if you don’t share this sentiment you shouldn’t be an anaesthetist.
- You are working in tandem with Obstetricians and Midwives- both strange breeds.
- Your patient and her partner/ significant other/ support person are both incredibly anxious. This anxiety is often compounded and reflected by the demeanour of the obstetrician, midwife and paediatric doctor. Foetal distress= obstetric distress. Patients will sense your anxiety and if all the caregivers in the team are on edge this does not lend itself to an optimal perioperative environment.
- You are always under time pressure- even with elective obstetrics.
- When things go bad, they usually go really bad. You may be put in the very difficult situation of being asked to help resuscitate a critically ill baby as well as looking after that baby’s mother.
- Regional anaesthesia, with its attendant limitations, is the predominant mode of anaesthesia. I don’t have personal experience but I can appreciate that it is very strange to be awake knowing you will have a great big cut made over your abdomen and then have two people poking and prodding your nether regions. You need to be intimately familiar with the wide interindividual variability of the subjective experience with regional anaesthesia.

For the above reasons it is beholden upon the obstetric anaesthetist to be confident and radiate confidence. Confidence implies you are competent as well as in control. You need to be absolutely clear and precise with your communications; know what you are doing and be able to recognize when things aren’t progressing as they should and to intervene appropriately.

We will consider in detail the following aspects of obstetric anaesthesia:

- Physiological changes of pregnancy
- Anaesthesia for Caesarean section (CS)
- Postpartum haemorrhage
- Obstetric Epidurals
- The morbidly obese parturient

Physiological changes of pregnancy

It is important to understand these as they have implications for anaesthetic management. The following points are a summary of the major changes and you would probably pass a viva if you could remember them all. Pregnancy is an anabolic state.

- Cardiovascular:
 - 50% increase in cardiac output achieved by mid trimester mostly by increased stroke volume and to a lesser extent by increased heart rate.
 - TPR is reduced maximally at mid trimester and this correlates with a slight fall in blood pressure seen at this stage of pregnancy.
 - 40% increase in blood volume with a relatively larger increase in plasma volume versus red cell mass resulting in a dilutional anaemia.
 - Increased uterine blood flow to total 750mls per minute, gravid uterus compresses vena cava when lie flat producing supine hypotension syndrome. Renal blood flow is also increased.
 - During labour cardiac output increases up to a further 50% during contractions and reaches its peak value immediately after the placenta has been expelled.
- Respiratory:
 - 20% decrease in FRC which decreases a further 30% when going from upright to the supine position, little change in total lung capacity.
 - 20% increase in oxygen consumption, 50% increase in minute ventilation largely due to increased tidal volume.
 - Compensated respiratory alkalosis.
- Others:
 - 30% decrease in MAC.
 - Pro-thrombotic state with increase in Fibrinogen levels and other clotting factors.
 - Impaired glucose tolerance, delayed gastric emptying in labour.

Anaesthesia for Caesarean Section

Why is regional anaesthesia preferred for CS?

- Safer- See the UKCEPOD reports, "Saving Mother's Lives". The reports were previously entitled less sanguinely, "Why Mothers Die". GA CS still has the deserved association with higher morbidity and mortality although the degree of difference continues to wane. There is still an increased incidence of difficult airway management in the pregnant patient as reported in the Australian GA CS study (see selected references).
- Other benefits- better analgesia, less DVT, possibly less blood loss, partner can be present, maternal bonding, ?better foetal outcomes (no evidence). These are all secondary considerations to the fact that you are less likely to **kill** the mother and baby with a regional anaesthetic and this point should be reinforced to all parturients.

Choice of mode of anaesthetic

- Spinal vs CSE vs Epidural
- Spinal is simplest, fastest and most reliable. No evidence to say it is safer/worse than an epidural with regard to any outcome.

- CSE- gives ability to prolong duration of anaesthesia but is an untested epidural. Difficult to know when to augment block and with how much.
- Epidural- slow onset, less reliable. Desirable for slow onset sympathetic block in pt with cardiac disease. Can be technically easier in some pts.
- Be aware of failure rate for regional anaesthetic- 3% at my hospital. Specifically warn the patient and her partner of this and be prepared to convert to GA- more on this later. Explain to the partner that in the event of conversion to GA they will have to leave the theatre.

CI to regional anaesthetic

- Absolute contraindications are:
 - Pt refusal- this is the commonest indication for a GA in my hospital
 - Localized sepsis at puncture site
 - Untreated coagulopathy/ thrombocytopenia
 - Raised intracranial pressure
- Long list of relative contraindications- exercise caution in patient with neurological disease especially if it is active. No evidence to suggest regional anaesthetic per se alters the course of underlying neurological disease but distinguishing a relapse of the disease from a neurological complication of the technique can be very difficult. Previous back surgery inc. Harrington rods aren't a contraindication but may make it technically difficult. Most anaesthetists would favour a regional approach for placenta praevia now.

Preoperative Assessment

- All the usual including airway assessment and look at the back for scars, skin dimples (spina bifida occulta), rashes and the presence or not of landmarks.
- Obstetric history- G?P? and position of placenta. The table below describes the relationship between previous CS, placenta praevia (PP) and the rate of placenta accreta.

PP WITH UNSCARRED UTERUS	5% RISK ACCRETA
PP+ 1 PREV CS	24%
PP+ 2 PREV CS	47%
PP+ 4 PREV CS	67%

- Investigations- need Group & Hold taken within a week at an absolute minimum. I wouldn't start an elective LSCS without a current Group and Hold. Baseline FBE is also indicated.
- Premedication- probably a waste of time. Standard practice remains ranitidine 150mg po for two doses.

Conduct of spinal anaesthetic

- Informed consent. Ensure preoperative foetal heart rate check has been done before you start.

- 16G IV access- obstetric haemorrhage can be torrential and unpredictable. Be aware the average blood loss for a CS is 750mls- if it looks like a lot then blood loss is likely to be well over a litre.
- Give antibiotics pre skin incision- 2g Cephazolin is the current recommendation as per Therapeutic Guidelines. A Qld study reported a significantly decreased rate of surgical site infections when antibiotics were given pre-incision. Give this prior to your spinal so you don't confuse it with anything else (vasopressor, syntocinon) and if they have an anaphylactic reaction you know what it was to!
- Aseptic technique- this requires meticulous care and attention to detail. The recent case in Australia of a woman dying from infective complications from an obstetric epidural and another lady sustaining severe permanent neurological damage after chlorhexidine was injected epidurally have dramatically reinforced the importance of this technical aspect being performed assiduously.
- Heavy bupivacaine- dose can be altered for height (more) and weight (less) but I wouldn't use less than 2.0 or more than 2.5mls. Opioid isn't necessary for intraoperative anaesthesia but most practitioners add fentanyl to 'enhance' the quality of the block. Use same dose in twins as for singletons.
- Commence vasopressor infusion immediately after the spinal injection- aim to keep BP at preblock values. An infusion achieves this more reliably than a bolus method. Phenylephrine is the current agent of choice- more efficacious than ephedrine with no adverse effect on cord pH. May get bradycardia with high infusion rates. There is considerable published work by Warwick Ngan Kee on this topic. **Prepare phenylephrine in a labelled syringe and administer via dedicated syringe pump.** (I squirt 1x10mg ampoule into 100ml bag saline and draw off 20mls into syringe- works out 100mcg/ml. Start at 20mls/hr and titrate.)
- There is no role for fluid preload or routine supplemental oxygen.
- Must assess and document level of block- minimum criteria are ice to T4 or soft touch (blunt drawing up needle) to T5. Don't let the obstetrician start if you aren't sure about the block. If your patient doesn't have significant motor block then you aren't ready yet. Don't ask them to wriggle their toes because they will be able to do this for the next fifteen minutes. When testing with ice place it on the patient's arm first to demonstrate how cold it is and then ask them to tell you when it feels cold like that again. Slide it along their abdomen until they say it is cold and then continue upwards until they wince ("that's really cold") as this is the threshold you are looking for. Don't prompt the patient at all when the obstetrician 'tests' the block for you- an unprompted "Ouch, ouch, ouch" as the forceps are applied is testament enough that your block is not adequate.
- Ensure there is left lateral tilt on the operating table once the mother is positioned on it. The books talk about 15 degrees of tilt- this is quite a lot and your obstetrician will invariably complain with this much so I suggest enough so that the table *looks* obviously tilted. If she is hypotensive or feels nauseated despite phenyl then you may have to turn them into a full lateral position until the haemodynamics normalize. If they are hypotensive and tachycardic they need a bolus of phenyl on top of the infusion rate which should be increased. If they are hypotensive and bradycardic they are having a vasovagal in which case don't bolus the phenyl.

- With the delivery of baby (last baby if multiple gestation) give 3 units syntocinon as a slow IV bolus once the cord is clamped. Remember synto is a potent vasoactive drug and causes vasodilation- hypotension and a reflex tachycardia. Don't give it if the patient is haemodynamically compromised. Subsequently commence a syntocinon infusion 20U in 500mls saline in labelled bag via a IMED giving set. Some centres use carbetocin, which is a long acting synthetic analogue of syntocinon administered as a single bolus dose (100mcg). My experience is obstetricians routinely ask for a synto infusion regardless so I don't use it.
- Most obstetricians like you to level the bed once the baby is out.
- Chart fluids, analgesics, antiemetics, APS forms and stickers as appropriate.

Postoperative Analgesia

- Prescribe regular paracetamol and NSAID (Diclofenac 50mg tds, Ibuprofen 400mg tds) unless contraindicated (eg. PIH) for all pts
- Current commonest option is use of SR Oxycontin + prn Endone/ tramadol for breakthrough pain. Patient given stat dose 20mg Oxycontin in recovery and is charted 10-20mg Oxycontin bd for a further 4 doses. All sustained release opioids including stat doses are to be charted on the patient's regular medication chart.
- PCAs are rarely required with the above regimen, even if the patient has had a GA.
- Intrathecal (IT) morphine is cheap, easy, safe and efficacious. The dose is 100mcg. Care must be taken to draw up the correct dose. Errors in this respect have largely contributed to the decreased use of IT morphine in my centre.
- Caution with IT morphine if history of herpes. Certainly avoid if current infection and most wouldn't if recent either. There is some evidence to suggest a recurrence of herpes infection is more likely with neuraxial morphine.
- A TAP block is another analgesic modality that can be used to complement the above. Local infiltration to the skin only is probably a waste of time.
- If epidural in situ- epidural morphine 3mg. I recommend removal of the epidural catheter at the end of the case. Patient is not to have clexane for at least six hours after neuraxial puncture.

Managing common intraoperative problems

- Pain during procedure: commonest cause of litigation in obstetric anaesthesia. You must deal with this promptly and definitively. Is it pain? Where is it? What is the nature of it? You must be precise in determining what the problem is. What is the obstetrician doing? You must be vigilant in keeping an eye on your anxious patient as well as the progress of the operation. Anticipate likely episodes of discomfort with stretching of the peritoneum, exteriorizing of the uterus (a crude manoeuvre Queensland obstetricians are fond of) and wiping out the paracolic gutters. For the latter, a bolus of IV fentanyl/ alfentanil may be adequate to manage the problem. They will be acutely aware of a very strong sensation of pressure on the chest with the actual delivery and it is prudent to 'talk your patient' through these phases. **BUT:** Have a low threshold to convert to GA. If you are unsure specifically ask the patient if she wants to be put to sleep. There would have to be *remarkable* circumstances not to comply with a patient request to convert to GA.

Even if you think the block is fine if you have a distressed patient (and partner) you have a big problem. Don't sedate the patient. Sedation is inappropriate management of inadequate anaesthesia. Until the rectus sheath is closed, if you have a patient complaining of persistent pain I believe you are compelled to convert to general anaesthesia.

- Itch- expect this with everyone having IT morphine. Will resolve after 12-20hrs. Antihistamines are minimally effective and probably 'work' more via their sedative action. Ondansetron is minimally effective and Naloxone is probably the best agent- can give IV as infusion or as a 'sniff'.
- Nausea/ Vomiting- common but less so with careful attention to maintaining normotension. Check BP and operative field before giving an antiemetic.
- Bleeding- see below.

Emergency Caesareans

- Categories of emergency CS which are an international standard of classification and are endorsed by RANZCOG:

Cat 1 immediate threat to life of woman or foetus (=STAT CS) do ASAP eg. Cord prolapse, sustained profound foetal bradycardia. Usually get GA but not always. Some would say the only indication for a GA is if a regional is contraindicated- these people are in the minority as reflected by current practice. (Concept of 'rapid sequence spinal'- gloves, alcowipe, no local, inject healthy dose of marcain- I've never done it.)

Cat 2 maternal or foetal compromise which is not immediately life-threatening. Mostly this is for foetal distress= obstetric distress.

Cat 3 needing early delivery but no maternal or foetal compromise. Similar to Cat B, can't wait 24hrs etc, eg. Booked CS in labour, stable PIH.

Cat 4 at a time to suit the woman and maternity team, i.e. elective

There are no validated time intervals for any of these categories. Most clinicians can agree on the truly urgent cases. Category 2 CS's will always be subject to debate. Obstetricians are the most impatient creatures on the planet.

- Cat 1 CS- don't start GA without consultant anaesthetist present if you: have no obstetric experience/ have less than six months anaesthetic experience/ are not happy.
- Mode of anaesthesia- epidural top-up if epidural catheter in situ, otherwise same as above. I recommend using 2% lignocaine with adrenaline + amp of fentanyl- this is the least cardiotoxic local anaesthetic available and allows you to give the largest dose of LA. The vast majority of ladies need between 10-15 mls of this mix to get a block dense enough for surgery. (If the woman weighs 100kg this is about a third of her maximal LA dose- 7mg/kg.) Give this in increments and monitor closely. If the epidural is not great then I recommend not topping it up but to remove the catheter and perform a spinal using a 'lowish' dose- I'd still inject 2mls heavy marcain. You can't dump 20mls of local down a catheter and then do a spinal!

Do not be like your obstetric colleagues and forget about the components of 'In Utero resuscitation' aka **SPOILT**- **S**ynto off, **P**osition full lateral, **O**xygen, **I**V fluid bolus, **L**ow BP- vasopressor, **T**ocolysis. The most effective and rapidly acting tocolytic agents are sublingual GTN for the awake parturient and Sevoflurane for the asleep parturient.

The GA CS

This demands respect and the best personnel in the best circumstances. No one is at their best at 3am when a stat CS is called so you must be well drilled with your approach to this challenging situation. The main benefit of a GA over a regional anaesthetic is not speed but that it is reliable and grants you the most control over the patient. I am especially thinking of the airway (secure) and haemodynamics (not combating sympathetic blockade as well as the bleeding which is hazardous enough).

This is my approach, I don't pretend it is the only one but the points made are valid.

- Assess the airway and expect a difficult intubation even if it looks okay. The failed intubation rate is still much higher in this patient group: one in three hundred. The incidence of difficult intubation is three percent. There is always a degree of airway oedema. Ask about allergies yourself again. Give sodium citrate if you have time. Beware of hair buns, they cause difficult intubations.
- Must have a decent IV- won't be any easier to find one when they're flat and you really need one.
- Make sure a Group & Hold has at least been sent, paediatric staff are on their way and the obstetrician is physically present before inducing anaesthesia.
- Preoxygenate well realizing they will still rapidly desaturate despite your best efforts. Don't forget left lateral tilt because everyone else has.
- Rapid sequence induction with generous dose of propofol* (don't use thiopentone unless you're familiar with it and no trainees are), sux and flush it in. Stubby handled laryngoscope +/- Kessel's blade with stylet in tube. Favourite videolaryngoscope on standby and use this first if there is any hint that it will be tricky. There is no stubby handled videlaryngoscope on the market, incidentally. (*Be aware the propofol PI still labels it as a Cat C drug and states "Propofol should not be used for obstetric anaesthesia" although everyone does.)
- If the woman has PIH then you must give something to obtund the pressor response to intubation and I would use 20mcg/kg of alfentanil given immediately before the propofol.
- Have failed intubation drill clear in head: 2 attempts at intubating then LMA, if can ventilate well then proceed, if not happy with seal then wake up. Very rarely are patients woken in these scenarios. If in CICO situation proceed to surgical airway. The DAS Obstetric Algorithm for failed intubation is reproduced below. Be aware that there is considerable published experience with the use of LMAs for both elective and emergency GA CS. Second generation LMA is preferred.
- Don't let the obstetrician start until you are certain the tube is in the right place otherwise you will have fundal pressure and bleeding to contend with as well as an airway that hasn't been secured.
- Maintain anaesthesia with Sevo in 50:50 mix of oxygen and nitrous. MAC is reduced in pregnancy but I would still aim for combined MAC of 1.0. Nitrous is for the purposes of volatile sparing.
- Forget about BIS.
- The most crucial time interval with respect to neonatal morbidity is the uterine incision to delivery time. Unfortunately you cannot control the duration of this interval but you can ensure optimal oxygenation and perfusion of the mother during it.

- Monitor NMJ and use small (quarter) dose of NDMR if required.
- Generous slug of opioid once baby is out.

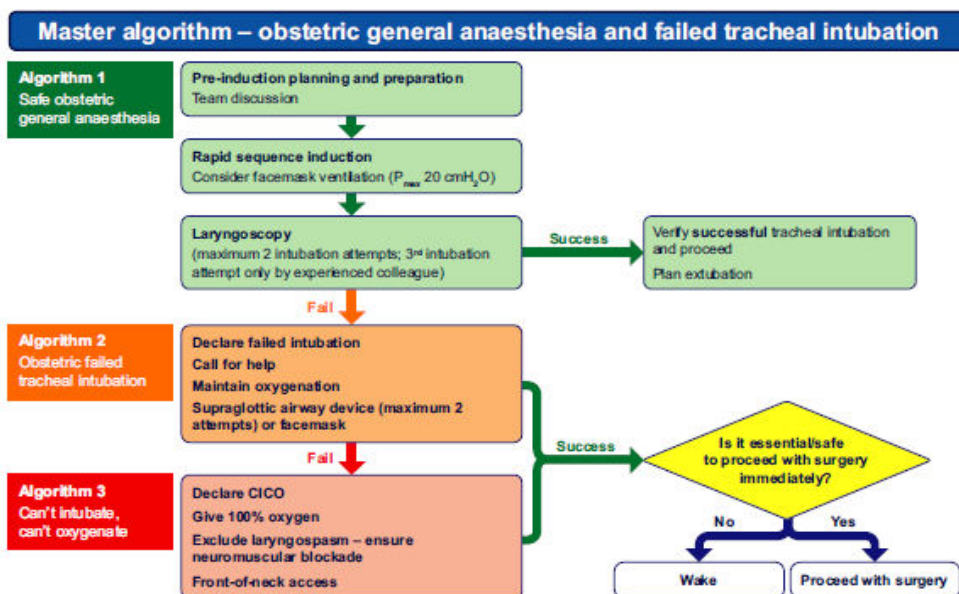

Postpartum Haemorrhage (PPH)

Undoubtedly, this is the most common obstetric emergency and a leading cause of death in the peripartum period. Obstetric haemorrhage is difficult to assess on clinical grounds alone as it may be hidden and healthy parturients tolerate significant blood loss remarkably well. It is invariably underestimated. If a woman has bled enough to warrant being booked to come to theatre for management of PPH you can be assured she has already lost at least two litres. If she is tachycardic she has lost 40% or more of her blood volume. Hypotension and any degree of obtundation is a dire sign of critical hypovolaemia. As always the clinical priority is to stop the bleeding. Concurrently aggressive fluid resuscitation must be in progress and this warrants dual large bore IV access. Administering blood products is a lesser priority and does not stop the bleeding. General anaesthesia is the preferred mode of anaesthesia for the same reasons as described for a GA CS.

Recall the causative factors of PPH, the four 'T's- tone, tissue, trauma and tendency to bleed- and the adage that an empty, contracted uterus does not bleed. As anaesthetists we are involved in resuscitating, anaesthetizing and facilitating the medical management of the woman with PPH.

It is important to be familiar with the management options of PPH and their anaesthetic implications. These are detailed below. See also *The Bleeding Patient and Transfusion Therapy*.

- Management of PPH can be divided into three main areas:
 - Medical- physical and pharmacological measures
 - Surgical- see below

- Radiological- placement of uterine artery balloon catheters, uterine artery embolization. This is available in tertiary centres only and more usefully and commonly employed prophylactically if at all.
- There are multiple case reports of the successful use of recombinant activated Factor 7 (RANZCOG recommended dose 90 mcg/kg up to 2x) where other measures to stop bleeding have failed.
- The use of the Cell Saver is not contraindicated in obstetrics.

Immediate Management

- Call for SENIOR HELP
- Cease epidural infusion if running and disconnect it from the epidural filter and bung it.
- Secure large bore IV access x 2 or RIC and ensure a Crossmatch specimen has been sent. (Midwives routinely take bloods when they cannulate parturients and keep the tubes in their fridge in my hospital.)
- Resuscitate with normal saline/ colloid until blood is available.
- Give supplemental oxygen and get the nurses to insert an IDC if this hasn't already been done.
 - Assess the patient's airway and perform a rapid anaesthetic assessment. Give Na Citrate 30 mls PO
- Prepare OT:
 - Inform anaesthetic tech, nurse coordinator
 - Draw up drugs inc. vasopressor
 - Pressure infuser- Level 1 primed.
- In the situation of massive vaginal bleeding despite Syntometrine IMI/ Syntocinon infusion/ manual 'rubbing up' of contractions, options are:
 - Bimanual compression of uterus ±
 - Direct external aortic compression on the way to OT.

Intraoperative Management

- Actively warm patient.
- Consider arterial line but don't delay surgical intervention.
- Anticipate the need for FFP/ platelets/ cryoprecipitate; send baseline bloods but usually need to give blood products before lab results are available. Hemocue gives an accurate and objective measure of haemoglobin concentration. Activating the Massive Transfusion Protocol is appropriate for cases of major PPH.
- If uterine atony:
 - Syntocinon. A synto infusion is invariably already in progress- giving further boluses is both ineffective and dangerous and invariably this is requested by the obstetrician. Beware this agent is a direct vasodilator and can cause a precipitous drop in BP if given as a bolus to a shocked patient.
 - Ergometrine may be effective- give 500mcg (1amp) IMI or dilute in 10mls and give 100mcg IV boluses and assess response. More commonly an amp of Syntometrine is given imi= 5units synto + 500mcg ergometrine. Caution with hypertension with this drug and avoid it in PIH. A high incidence of nausea and vomiting warrants administering an antiemetic in conjunction with this drug.

- Dinoprost, PGF_{2α} is a prostaglandin drug intended for injection directly into the myometrium. It is supplied as a 5mg/1ml amp. It should be diluted in 10mls saline= 500mcg/ ml. It should be injected into each quadrant of the uterus up to a maximum dose of 3mg (6mls). This drug can cause bronchospasm and pulmonary hypertension and is relatively contraindicated in asthmatics. An alternative formulation is Carboprost which comes as a 250mcg in 1ml ampoule. It is given IMI with doses being given 15 minutes apart up to a total of 8 amps.
- Misoprostol, PGE₁ analogue, give 3-4 200mcg tabs PR. Slow onset of action. May cause pyrexia.
- Surgical options include:
 - B-Lynch suture- analogous to trussing the uterus like a rolled roast. Uterus needs to be contracted first for this to be effective. Described in context of bleeding LSCS, full thickness sutures are placed through the lower segment incision.
 - Foley catheter placed in cervix and inflating balloon.
 - Specialized catheters for intrauterine use are also available, eg. Bakri balloon.
 - Uterine packing- needs to be removed after 24hrs.
 - Uterine/ internal iliac artery ligation.
 - Subtotal or total hysterectomy- former more commonly done as cervix hard to identify and leaves pedicles. This may be life-saving and shouldn't be reserved as an absolute last resort.

Postoperative Management

- Check hemocue again.
- Don't forget antibiotic cover- Cephazolin 2G, Metronidazole 500mg.
- Persisting tachycardia is abnormal as is hypotension.
- Patient will need to go to a high dependency environment or be 'specialled' in Birthing Suite at a minimum.
- Remove the epidural catheter if you haven't already. They should have an IDC in situ.

Obstetric Epidurals

Consent:

You still need to obtain consent prior to siting an epidural. Verbal consent is okay but you need to document it somewhere and nothing is better than a signed consent form when the lawyers get involved. Although these patients are in pain their brain still works fine and they are able to process and remember information given to them. Below is a reproduction of the consent form used at my hospital. I like at a minimum for ladies to have read this, I then tell them specifically about the risk of failure/ inadequate analgesia and PDPH and give them an opportunity to ask me any questions.

 <p>Queensland Government Queensland Health</p>	<p>TOOWOOMBA AND DARLING DOWNS HEALTH SERVICE DISTRICT</p> <p>Obstetric Epidural Consent Form</p>	UR No: _____ Surname: _____ Given Names: _____ Address: _____ DOB: _____ Sex: _____ <i>(Please affix patient identification label here)</i>
	Facility: _____	
<p>During your labour, you may ask for or be recommended to have an epidural for pain relief. This information is to help you make an informed decision about this.</p> <p>What is an epidural?</p> <p>An epidural refers to injecting a mixture of local anaesthetic and pain killing medicine around the nerves close to the spinal cord. The injection is usually done through a piece of plastic tubing which is placed in the epidural space using a specially designed needle. The medicines act to block the pain signals associated with labour. Once the epidural is inserted it takes about twenty minutes for it to start to work effectively.</p> <p>As with all medical procedures, epidurals are associated with side effects and complications. The benefits and risks of epidurals are described below.</p> <p>Benefits</p> <ol style="list-style-type: none"> Excellent pain relief – It is generally accepted that labour is the most painful experience that most women will experience in their lifetime. An epidural provides the best quality of pain relief compared with any other method e.g. 'laughing gas', pethidine injections, massage, TENS. Safe for baby – All drugs given to the mother cross the placenta and are found in the baby in small amounts. The drugs used in epidurals are safe and have minimal effect on baby. Less discomfort with interventions – During the course of your labour the doctors may need to do a forceps or vacuum delivery. An epidural may make these procedures a lot more comfortable for you. Blood pressure control – If your pregnancy has been complicated by the development of high blood pressure (pre-eclampsia), then an epidural will help to control this. <p>Side Effects <i>(occur with most epidurals to some extent)</i></p> <ol style="list-style-type: none"> Loss of other sensations – As well as pain, sensations other than pain, eg. touch and temperature, are blocked. Muscle weakness – The nerves going to the muscles are affected to some degree as well. This means that you may have temporary weakness of your legs. Because of this you are confined to the bed while the epidural is in place. Lower blood pressure – Your blood pressure may go down because the nerves going to blood vessels are blocked. You may need fluids and medications to normalize your blood pressure. Weak bladder – Automatic control of your bladder is affected and often a urinary catheter is inserted once the epidural is working. Shivering – It is common for women with epidurals to get the shakes. This is not harmful and will go away once the epidural is removed. <p>Complications <i>(listed in order of frequency)</i></p> <ol style="list-style-type: none"> Failure of block: 1 in 20 It can be difficult to insert the epidural needle in some people. This may result in a failure to insert the epidural or a partial block. This may result in incomplete pain relief. Reinsertion may be necessary in cases of ineffective block. Headache: 1 in 100 This can be severe but is very rarely dangerous. It will go away in time but there is an effective treatment if it is causing too much discomfort. High block: 1 in 1400 Sometimes the epidural block can rise to a high level. If it is very high you may need a general anaesthetic and assistance with breathing until this wears off. 		

Name:	DOB:	UR:
<p>4. Temporary numbness: 1 in 2200 Rarely, areas of numbness, "pins and needles" and weakness can persist for hours to days. This is more likely to be from childbirth itself than from the epidural. These areas of abnormal sensation will fully recover.</p> <p>5. Permanent nerve damage: 1 in 11,000 to 1 in 240,000 This is very rare and if it does happen most commonly involves one nerve only.</p> <p>6. Seizure: less than 1 in 11,000 If the epidural medications are injected into a vein in the epidural space, seizures and abnormal heart rhythms may result. These are potentially life threatening but can be managed safely.</p> <p>7. Infection in epidural space: very rare, 1 in 145,000 Infection can occur in the epidural space causing an abscess. This may need major surgery to drain the abscess.</p> <p>8. Epidural haematoma: very rare, less than 1 in 168,000 Very rarely a collection of blood in the epidural space can press on the nerves in the spinal cord and damage them. This may result in permanent paralysis.</p> <p>Problems not affected by epidural analgesia</p> <p>1. Back Pain You may experience some bruising around the insertion site which will resolve in a day or so. Back pain is very common during pregnancy and epidurals don't change this problem.</p> <p>2. Caesarean Section Rate The best available evidence concludes that there is no evidence that having an epidural will make you more likely to need a caesarean section. However there may be an increased chance of needing an instrumental delivery, e.g. vacuum or forceps.</p>		
PLEASE DO NOT SIGN THIS UNTIL YOU HAVE BEEN SEEN BY THE ANAESTHETIST		
<p>I, (print name) have read the above and have asked the anaesthetist about everything I did not understand. I wish to have this procedure performed.</p> <p>Signature:..... Date: / /</p> <p>Witnessed by anaesthetist (signature) Date: / /</p> <p>Print name and designation:</p>		

DO NOT WRITE IN BINDING MARGIN

DO NOT

A default recipe:

Most centres use patient controlled epidurals administered by dedicated pumps with dedicated tubing.

Our default program is: background infusion 4mls/hr, bolus 4mls, lockout period 15mins, maximum 20mls given per hour. We use premixed bags of 0.2% ropivacaine + 2mcg/ml fentanyl. Epidural loaded with 40mg ropivacaine + 100mcg fentanyl in 10mls volume with saline- this is given incrementally with the expectation that the woman should be comfortable 10-15 minutes after completion of the loading dose. Between the first and second increment you must determine if your catheter is intrathecal or not. In our hospital we use a epidural insertion form as a cognitive aid and audit tool.

Troubleshooting epidurals:

The more epidurals you do the more strange things you will encounter. My approach to the 'dodgy' epidural is as follows:

- Assess the block objectively yourself. No block is no good. If the woman was comfortable they wouldn't have called you! Look at her back to check the catheter isn't dislodged.
- Give a bolus 5mls 2% lignocaine with adrenaline, wait ten minutes and re-assess.
- If no block/ ipsilateral or lopsided block/ catheter dislodged/ still crappy block after bolus- resite the epidural. You should expect to resite at least 1 in 20 (5%) of your epidurals.

What to do if you have a dural puncture:

- It is usually obvious and invariably disheartening to all concerned.
- Option one- pull everything out and try again at another level. Expect a PDPH, document the puncture clearly and explain to the patient what happened. Load your subsequent epidural cautiously as there is a theoretical risk of drug flux into the intrathecal space.
- Option two- thread the epidural catheter and use it as an intrathecal catheter. In this event you will need to be utterly paranoid and only let anaesthetic staff inject anything down it. Label it clearly as an intrathecal catheter. If it doesn't thread easily, pull out and revert to option one. If you use the catheter- leave it in situ for 24hours post delivery but do not run anything down it. Care with the timing of clexane in this instance- withhold dose until 2 hours after removal of the catheter. There is reasonable evidence this markedly reduces the rate of severe PDPH (see Selected References).

Remifentanyl PCA:

I have no experience with this modality in obstetric practice yet it is being increasingly employed in obstetric units in Australia and New Zealand. This is most commonly in the context where an epidural is contraindicated or unsuccessful. This modality is safe and effective presuming the attending staff have been trained in its use and management. Supplemental oxygen must be given and the mother is closely monitored including the use of continuous oximetry. A dedicated pump programmed for bolus only delivery is required.

A regimen is described below:

2mg Remifentanyl in 100ml bag saline = 20mcg/ml.

Program bolus beginning at 0.25mcg/kg (up to 100kg), lockout 2 minutes.

Increase bolus by 10mcg (0.5ml) increments every ten minutes up to a maximum of 0.5mcg/kg.

Maternal Collapse post epidural:

A favourite final exam scenario but fortunately quite rare in practice. The differential for this is:

- FAINT- VASOVAGAL (commonest cause by far including the collapse of fathers-to-be in attendance)
- AORTOCAVAL COMPRESSION causing hypotension
- HIGH BLOCK/ TOTAL SPINAL
- SYSTEMIC LA TOXICITY (know where your intralipid is kept)
- ANAPHYLAXIS

- SEIZURE- epilepsy, eclampsia, hyponatraemia
- EMBOLISM- air, thrombus, amniotic fluid
- HYPOTENSION/ HYPOXAEMIA/ HYPOGLYCAEMIA

Look after the mother and the baby will be similarly cared for.

The morbidly obese parturient

- See also *The Obese Patient*
- These patients are more likely to have every possible complication you can think of, both in obstetric and anaesthetic terms.
 - Obstetric- maternal PIH (14-25%), gestational diabetes (6-14%), increased incidence caesarean section and instrumental delivery, more likely to fail to progress and have shoulder dystocia, increased incidence wound infection and endometritis, increased operative blood loss and more likely to have a PPH and thromboembolic disease.
 - Foetal- macrosomia, increased risk birth defects, increased intrapartum foetal distress and meconium aspiration. Association with higher neonatal mortality.
 - Anaesthetic- difficult airway management more likely as are adverse effects including death and aspiration, regional anaesthesia technically more difficult and more likely to fail.
 - If you are called to site an epidural in an obese primip, there is a greater than fifty percent chance you will anaesthetizing them for a caesarean section later in the day. These are the facts. Make sure that epidural is working.
- They are more likely to have co-existing co-morbidities namely diabetes, hypertension, OSA and gastro-oesophageal reflux disease.
- All the Guideline documents consistently recommend the following:
 - The most experienced, senior personnel should be directly involved with the care of these women.
 - Complex patients demand a clearly documented and agreed upon multidisciplinary management plan.
 - An antenatal consultation with an anaesthetist is recommended (I do think this is a waste of time if they are *just* obese).
 - These women should be fasted when in active labour and given antacid prophylaxis.
 - Anaesthetic services should be alerted when they are admitted to the labour ward and there should be a low threshold for early epidural analgesia and obtaining IV access.
- For the MO parturient presenting for CS- have a low threshold for an arterial line and two decent IV cannulae. Neuraxial anaesthesia may be difficult and an experienced practitioner is the best 'tool' to manage this problem. CSE or epidural analgesia may actually be easier than a spinal and certainly should be tried before abandoning this mode of anaesthesia. Ultrasound may be useful to determine the midline and the depth to the epidural space. Use the same dose spinal as for a non obese parturient.
- GA CS for the morbidly obese parturient demands respect and the best possible circumstances you can arrange.

SELECTED REFERENCES

Difficult and failed intubation in obstetric anaesthesia: an observational study of airway management and complications associated with general anaesthesia for caesarean section. N Mc Donnell et al. *International Journal of Obstetric Anaesthesia* 2008; 17: 292-7.

Saving Lives, Improving Mothers' Care. Lessons learned to inform future maternity care from the UK and Ireland Confidential Enquiries into Maternal Deaths and Morbidity 2009-12. M Knight et al eds. MBRRACE-UK. December 2014.

Oxytocin bolus versus oxytocin bolus and infusion for control of blood loss at elective caesarean section: double blind, placebo controlled, randomised trial. S Sheehan et al. *British Medical Journal* 2011; 343:

Intravenous oxytocin bolus of 2 units is superior to 5 units during elective caesarean section. J Sartain et al. *British Journal of Anaesthesia* 2008; 101: 822-6.

Subarachnoid catheter placement after wet tap for analgesia in labor: influence on the risk of headache in obstetric patients. S Ayad et al. *Regional Anesthesia and Pain Medicine* 2003; 28: 512-5.

Obstetric Anaesthesia: Scientific Evidence. Obstetric Anaesthesia Special Interest Group, ANZCA, 2008.

Pre-incision antibiotic prophylaxis reduces the incidence of post-caesarean wound infection. J Brown et al. *The Journal of Hospital Infection* 2013; 83: 68-70.

LIGHT RELIEF

Things we'd like to hear an obstetrician say

- This is a stat Caesar but I don't expect you to endanger the mother's life by embarking on a crash induction.
- I don't think she needs a transfusion.
- I've got a woman with a PPH: I've put two 14 gauge cannulae in, have resuscitated her and sent blood for crossmatch. I will do the case personally as this is a high risk case.
- I exteriorize the uterus because I don't know better.
- Gee, that *is* a lot of blood.
- Can I just have a 2U bolus of syntocin and give it slowly.
- Cancel that emergency Caesar, she's delivered.
- I've sent the 180kg woman with placenta praevia to Brisbane.

OBSTETRICIAN GYNAECOLOGIST'S BRAIN

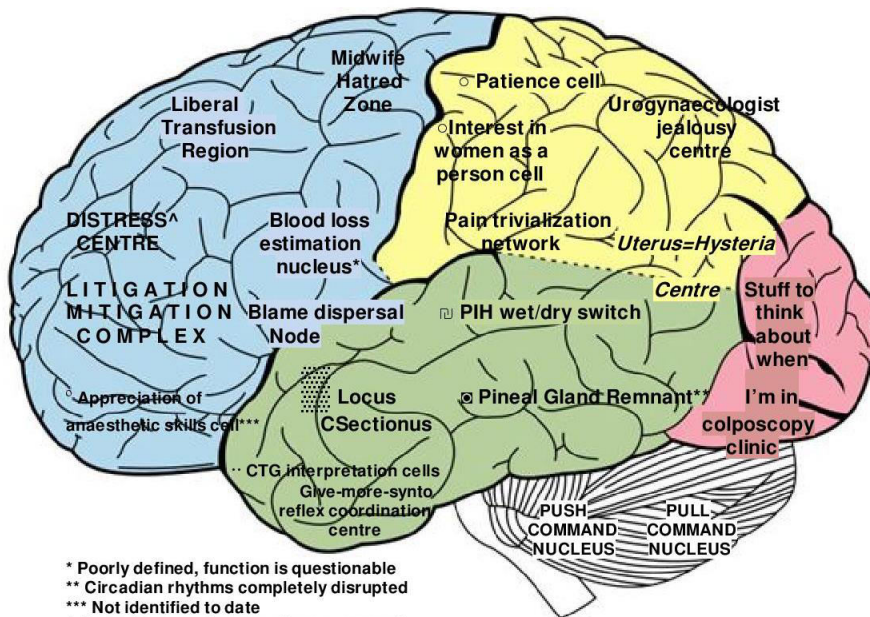

Paediatric Anaesthesia

Anything that can fit in a clothes basket makes me anxious if I have to anaesthetize it

Although paediatricians would hate me saying this, most children are, from the anaesthetist's perspective, little adults. Once they are more than about eight years old they generally will tolerate IV cannulation, will mostly listen to reason and can even use a PCA if you want to prescribe one. Most children are healthy and have straight forward airways and good veins. The challenge, most of the time, begins and ends at the induction. This chapter will not deal with complicated paediatrics, neonates or infants. You can buy a copy of *Cote* if you're interested in that, it is the Paediatric equivalent of *Miller*. Anaesthetizing infants is a true subspecialty and should not be attempted lightly. For this reason most anaesthetists are not credentialed to anaesthetize infants. Neonates will go into laryngospasm if you look at them the wrong way. There has been much interest in the adverse effects of anaesthetic agents on the developing brain and outside of the neonatal period, surgery on infants and children less than two is really quite infrequent. Common paediatric procedures performed outside of tertiary units are:

- ENT- grommets, adenotonsillectomy. OSA is the commonest indication for tonsillectomy in Australasia. Grommet insertion is the commonest operation performed on children in Australia.
- Orthopaedics- broken bones for MUA+/-ORIF.
- General surgery- 'lumps and bumps', hernias, skin lesions, circumcision.

Topics discussed in this chapter include:

- Analgesia for children
- Preoperative assessment and planning
- Gas induction
- Anaesthesia for tonsillectomy
- Syndromes you need to know about

Analgesia for children

When prescribing analgesic agents for children consideration needs to be given to: the procedure being performed and anticipated analgesic requirements; the available options; the correct dose; patient co-morbidities especially OSA and being able to justify your choice as a safe and cost effective one. The options are oral analgesics, rectal agents, parenteral agents preferably by PCA or NCA if the child is unable to use it, nerve blocks and neuraxial analgesia. I don't see the point of sticking things in children's bottoms- it is distasteful and the drug is unreliably and variably absorbed. Neuraxial modes are used very rarely in general paediatric practice.

The oral analgesic options are limited to paracetamol, paracetamol/ codeine mixtures, ibuprofen, tramadol and oxycodone. Paracetamol is well tolerated and there is a wealth of clinical experience with this drug even though it is a weak analgesic. The maximum daily dose of this drug is 90mg/kg for children. Most commonly it is given in divided doses of 15mg/kg and this can be given every four hours. Not four times a day which every paediatric resident on the planet seems to think. Codeine is rapidly being blackballed and I personally don't use it

anymore. In fact the UK and US have banned its use in children post ENT surgery. Breastfeeding mothers are recommended not to use codeine preparations. The TGA here released a document in October 2015 recommending it not to be used at all in children less than twelve and not in older children who have had adenotonsillectomy. See *Analgesics, Antiemetics and Local Anaesthetics* for more details. Ibuprofen is also well tolerated and a superior analgesic than paracetamol. They are commonly and appropriately prescribed together. The dose of ibuprofen is 10mg/kg tds up to a maximum daily total of 1200mg. Ibuprofen does not increase the risk of bleeding post ENT surgery although many ENT surgeons are reluctant to accept this Level 1 evidence. Be aware that tramadol is licensed for children greater than twelve years of age and oxycodone, the mainstay of most paediatric hospitals, is not licensed for children at all.

Earlier in the pharmacology section I discussed local anaesthetic dosing at length so won't revisit that topic. A penile nerve block is a very safe and effective option for circumcision and you should be able to do this block. Don't use local anaesthetic solutions that contain adrenaline for blocks involving the extremities- male genitalia included!

Preoperative assessment and planning

Most children are healthy and straight forward and have never had an anaesthetic before. They will all be worried about *the needle!* Don't lie or pretend that there are no needles involved. Most children that are less than about five or so will get a gas induction without the anaesthetist even suggesting or talking about an IV. It is worth spending some time with the older child explaining about the 'magic' local anaesthetic cream and how they will still feel a little scratch but it won't be bad. Don't forget that an IV induction is the safest, 'gold standard' approach for children as well as adults. Some kids won't have a bar of it and that's fine. Explain to the child and the parent that they will have an IV inserted at some stage. The parent is invariably as anxious, if not more so, than their child so you will spend most of your preoperative consultation calming them down and explaining what is going to happen. A fairly detailed explanation about gas inductions is important because it is a very foreign experience for the parent and can be quite distressing. Most people 'invite' one parent to accompany their child into theatre. Be aware that you don't *have* to and if Mum freaks out this won't help the cause. Before you go into theatre explain that once the child is asleep they will leave the theatre until they are called into recovery when their child has woken and settled (hopefully). A reproduction of the information sheet we give to parents of children not seen in clinic is reproduced below.

Fasting- same rules apply as adults. If the child is breastfeeding they can be fed up to four hours before the procedure. Incidentally if you are anaesthetizing a breastfeeding mother then they don't need to express and discard post anaesthetic. They can breastfeed normally as soon as they feel able to do so. Don't forget to reassure the parent that it is perfectly fine for the child to have plain water up to two hours before the procedure. Normal children do not become hypoglycaemic when they are fasting.

The child with an URTI- this is undoubtedly the commonest problem we are confronted with preoperatively. There is no textbook answer to this conundrum. The safest, ideal practice is to defer the surgery if you can. How long for no one knows but we know that the airways remain reactive for at least six weeks after an episode of bronchiolitis. The anaesthetic can undoubtedly make their chest infection worse. For the catastrophists out there, there are case reports of children with a viral illness becoming profoundly unwell post anaesthetic because they had a

viral myocarditis that no one realized they had. Having said that, if the child is afebrile, systemically well and has no chest signs then it is reasonable to proceed. Conversely, if they are too sick to go to school they are too sick to have an anaesthetic. A dreadful cough is probably adequate grounds to cancel them. If you proceed you should still warn the parent of the risks-exacerbating their infection, more likely to have laryngospasm and bronchospasm, will cough protractedly on emergence and may need to stay overnight. It is a very difficult situation for all if the child has come from Cunnamulla for an ENT procedure to alleviate their chances of getting recurrent infections that is causing the concern in the first place.

Planning the anaesthetic- they all get a GA of course. Chart the paracetamol and EMLA premedication. Size the LMA on their bodyweight and size the ETT on their age. Most anaesthetists use a micro-cuffed tube for all children if they are intending to intubate them. The $(\text{age}/4) + 4$ formula is the one to use. I round down if the formula gives me a number between X.0 and X.5 as the cuff will prevent a leak. If you are using a non cuffed tube then if the tube does not pass easily you should go down a size. Use Hartman's or normal saline for your drip not three and a third or anything hypotonic. Most children will be eating and drinking shortly after their procedure so it doesn't really matter what fluid you use in the vast majority of cases. I don't favour the use of burettes. They add bulk to everything, it can run through and it doesn't matter how much fluid you give them if it isn't hypotonic. Most people use pressure controlled ventilation and you will need a faster respiratory rate and a higher pressure setting than for an adult. The smaller the child the higher the settings. Ultimately you will titrate the settings to end up with an end-tidal CO₂ between thirty and forty. For anxiolytic purposes consider drawing up sux and atropine in separate 10 ml syringes. It is easier to deliver an appropriate dose in the event of laryngospasm or bradycardia particularly for small children.

INFORMATION ABOUT YOUR CHILD'S ANAESTHETIC

The Department of Anaesthesia wishes to provide the very best quality of care for your child. Anaesthesia when administered by trained doctors in the appropriate environment is a very safe medical procedure. We strive to deliver safe anaesthesia for your child. This document is provided to help explain what we do to ensure your child is safely anaesthetized. It cannot be comprehensive but answers most of the commonly asked questions about anaesthesia.

PREOPERATIVE

Most children are not seen by an anaesthetist before the day of their procedure. We have a list of particular concerns that may require you to see us in a preoperative clinic but mostly we will see you on the day of surgery. A nurse may perform a health assessment of your child. **If you wish to see an anaesthetist prior to the day of surgery please contact the Bookings Officer on 46166268 and she will arrange this for you.** We try very hard to minimize the chance that your child's surgery is cancelled on the day for circumstances the anaesthetist was not aware of but that is always a possibility, albeit a small one.

The commonest cause for cancellation on the day is that the child is unwell. If you wouldn't send your child to school then they are too sick to have their surgery. The anaesthetist will assess your child on the day and if a decision to cancel surgery is made it is for the safety of your child.

Fasting- you will be given written advice what to do but the guidelines are very simple. Your child should be fasted from food and liquid (apart from plain water) for six (6) hours prior to surgery. Your child can have plain water only to drink up to two (2) hours prior to surgery.

Premedication- unless allergic to them all children are given a dose of paracetamol and local anaesthetic cream is applied to one arm preoperatively at hospital.

You will be given a *Consent to Anaesthesia* form which has some information about the potential risks of anaesthesia. On the day of surgery the anaesthetist will ask for your consent to the procedure and answer any questions you may have about it.

THE ANAESTHETIC

Virtually all children will receive a general anaesthetic- they will be 'asleep' for the procedure. There are two commonly used methods to 'go to sleep'.

- 1) Gas induction- anaesthetic gases are given to the child through a facemask. The gases smell unpleasant and there is often a degree of resistance from the child. As your child goes to sleep they may become restless and wriggle. Their eyes may roll back which is quite normal. Once the child is asleep a 'drip' will be inserted- this is essential for everyone having an anaesthetic.
- 2) Intravenous induction- this involves placing a 'drip' in the vein and injecting drugs into the vein to put your child to sleep. The local anaesthetic cream helps minimize the pain of insertion of the needle into the vein. This is the safest way to go to sleep but it can be difficult to place a drip.

One parent/ guardian may accompany the child into theatre at the discretion of the attending anaesthetist. You don't have to if you don't want to. We appreciate that a gas induction can be distressing for the parent and child but it is a safe procedure. Once your child is asleep you will be asked to leave the theatre as we continue to focus upon the very important job of looking after your child.

AFTER THE ANAESTHETIC

One parent/ guardian is usually invited into the recovery unit inside the theatre complex once their child has woken up from their operation. They will have a drip and will be prescribed medications for pain relief and control of nausea and vomiting. Many children can be distressed on awakening especially if they were when they went to sleep. A calm parent's presence can be very comforting in this situation. The vast majority of children would be expected to quickly resume eating and drinking after surgery and are well enough to be discharged soon after surgery.

Gas Induction

Like obstetrics, it is very important to radiate confidence and competence when you are anaesthetizing children. They can smell your fear. Everyone has their own little tricks to gain the confidence and compliance of the child they are about to render unconscious. The process starts when you first wheel them down the corridor. A good anaesthetic assistant can work wonders. It is handy to have a repertoire of jokes, stories and questions to ask of your little customer. Some people have their iphone or ipad loaded with appropriately silly video clips or games to distract the child. Waiting around really does kill the mood so don't get your patient unless you are just about ready to start the show. Sometimes it is a futile exercise and you just need to get on with things and induce anaesthesia as quickly and safely as possible.

We will consider the compliant child first. Show them the mask and let them hold it and smell it- most hospitals use scented masks that smell of strawberries or bubble gum depending on their socioeconomic status. Making sure everything is ready, bring the child in and place them on the operating table. Mum (mothers are far more frequently present than fathers) can carry a small child in but I prefer the child not to be on their lap- you have less control. A pulse oximeter should be applied to a digit at a minimum and then connect the circuit to the mask and let the child get familiar with it. "I've got a computer here that tells me how well you're breathing." Many people play the balloon game "let's see if you can blow this balloon up" but the important thing is you need a seal good enough to produce a capnograph and actually make the balloon go up and down. I use a fifty/ fifty mix of oxygen and nitrous because it's fun to play with the 'laughing gas'. Once you have established a seal and they are not pulling away then you can start introducing Sevoflurane. Be aware it smells awful and sickly sweet petrol fumes make an accurate comparison. I have the machine close enough so I can reach the vaporizer.

The natural inclination is for the child to reject this awful smelling stuff. This is when you need to control the situation and maintain that seal. I often start telling a ridiculous tale involving giraffes and banana skins and blue smarties to get them through this stage. I use phrases like “we’re going to make that funny smell even stronger. If you don’t like it you can blow it away...your eyelids must be getting droopy by now...” Expect the child to wriggle and squirm and for their eyes to roll back in their head and all this delightful stuff. Reassure the parent that *this is all normal* and that the child won’t remember anything from here on. Then I often invite Mum to kiss their child and then get the nurse to escort them out of theatre. Once you’ve ‘knocked down’ the child reduce the Sevo to about 4% and get the anaesthetic assistant to put the tourniquet on above their elbow, pull off the EMLA if it is there and have all the IV gear ready *before* you hand over the airway. Have a low threshold to pop a guedel in if they are obstructing. Put the IV in the easiest vein you can find and give whatever drugs you intend before you instrument the airway. I give them 1-1.5 mcg/kg of fentanyl and some white stuff which I have drawn up and ready.

Now to the non-compliant child. Again, warn the parent that the child won’t like this but it is necessary to get the job done. Display empathy if the parent is distressed. Continue to radiate unnatural degrees of confidence. The child usually won’t want to lie down so I have them seated on the edge of the operating table facing Mum. Apply oximeter, crank up sevoflurane to 8% and clamp the mask on firmly. I approach from behind with my right hand behind their head to support it and stop them arching away from the mask. If they take ten breaths of this they will effectively be asleep. This induction technique is mercifully rapid. Congratulate the parent on how well they’ve done and then get them out of there.

Anaesthesia for tonsillectomy

I have chosen this operation as it illustrates a lot of useful points. ENT surgery is overrepresented in terms of reports of adverse events in paediatric anaesthesia. Blood and airways are not an ideal combination. Preoperatively there is little new apart from clarifying why they are having the procedure- OSA, recurrent tonsillitis, both or the not so uncommon ‘don’t know’.

You can use a LMA or an ETT- this is dependent on the preferences of the anaesthetist and the surgeon. A reinforced LMA is used if you favour a supraglottic device because you can bend it out of the way and the tube is reinforced with a metal coil. I prefer a tube. It is the gold standard airway, it protects the airway from soiling, I don’t have to worry about leaks or misplacement and I don’t have to change it when things go pear shaped.

Most children get a gas induction as described above. Most children can be intubated deep under gas alone but I like to further deepen them with propofol and fentanyl before instrumenting the airway. Older children (more than eight or so) are managed more comfortably with a smallish dose of muscle relaxant but this is not an absolute requirement. There is less coughing and bucking and tachycardia with these forms of supplementation. Use an oral RAE tube so the tube points out of the way. Position it in the midline and secure it well. I use a strip of fixomul under and over the tube. Apply all your monitoring and make sure the top of the child’s head is level with the top of the operating table. Then, supporting the head

and tube, lift them and let the theatre orderly place a shoulder roll and the tonsil bar under the child. If they are having grommets done they need a head ring as well. Clip the airway tubing securely to the blanket to minimize the chance of the weight of the circuit pulling on the tube. Maintain anaesthesia with an age adjusted MAC. I use nitrous primarily as a volatile sparing agent to facilitate waking them at the end. Give them dual agent antiemetic prophylaxis- 0.1mg/kg of dexamethasone up to 4mg and the same dosing with ondansetron. They will already have had paracetamol so don't give them any more. They will need an opioid because tonsils hurt. It doesn't matter which one you use.

When the surgeon inserts the tonsil gag (Boyle Davis mouth gag holds the mouth open and compresses the airway) it is a good habit to manually ventilate the child so you can immediately determine whether you can ventilate or not. If you can't the surgeon needs to adjust the gag until you can. Then flip them onto the ventilator. It is not unusual to lose 5% of your blood volume in a routine tonsillectomy which is a not inconsiderable amount. When the surgeon has finished they will release the gag and lift the child's head and inspect the tonsil bed. This is your cue to lean in simultaneously and have a look. *A steady drip of blood is not adequate surgical haemostasis.* Don't wake them up until this has been achieved. Now wake the child unless you are doing a deep extubation. Let's assume we are not. The child should be in the lateral position facing you and blood should not be dripping steadily from their nose or mouth because this means surgical haemostasis has not been achieved! Be gentle with suctioning, you don't want to be scraping the raw tonsil bed. Once they are breathing regularly and just beginning to gag on the tube, remove it. If they can cry their airway is fine. Convince yourself they are breathing before you leave theatre. Postoperative orders should include consideration of whether they warrant continuous oximetry overnight if they have OSA. Regular paracetamol and ibuprofen is a good option for postoperative analgesia.

The bleeding tonsil

This is possibly the commonest paediatric surgical emergency. It is certainly life-threatening. The most senior and experienced personnel should manage this case. Bleeds have a bimodal distribution, either early in recovery (what did I say about surgical haemostasis) or delayed in association with secondary infection. The priorities are to resuscitate the child, induce anaesthesia and secure the airway safely and then allow the surgeon to stop the bleeding. If you are struggling to get IV access then use an intraosseous needle. If they are really flat the kid won't care. If they are so flat you can't get an IV in then they are obviously not adequately resuscitated. Resuscitate before you operate. Do not gas this kid off without IV access.

Prepare your theatre correctly: blood has been sent for crossmatch, you have two functioning suckers within easy reach, the difficult intubation trolley is in the corner, the surgeon is scrubbed and ready and the rigid bronchoscope is in theatre. Most people including myself would do a rapid sequence induction with sux and not much white stuff. The blood is the only thing making your intubation difficult hence the sucker. You have the best possible person standing there should you lose the airway- the ENT surgeon. The rigid bronchoscope is for their benefit.

Syndromes you need to know about

Down's syndrome, trisomy 21, is the commonest chromosomal abnormality. Children with Down's not uncommonly present on ENT, general surgical, dental and eye lists. The anaesthetic implications are:

- Airway- big tongue, short neck, atlantoaxial instability, increased secretions, subglottic stenosis and increased risk of OSA.
- Cardiovascular- high incidence of congenital heart disease with VSD, ASD and endocardial cushion defects. They should have had an echo done at some stage. Will need antibiotic prophylaxis.
- Intellectual impairment- problems with compliance and consent for the young adult.
- Others- tough veins, obesity, increased incidence of other conditions including hypothyroidism, epilepsy and leukaemia.

Cerebral Palsy is a symptom complex and is classified based on the extremity involved and the characteristics of the disorder. Spastic is the commonest form. The anaesthetic implications are:

- Epilepsy is common.
- There is a high incidence of reflux and a low threshold to intubate is warranted.
- There is variable cognitive impairment.
- They have impaired thermoregulation.
- Contractures may make positioning very challenging.
- Suxamethonium is not contraindicated.

The Muscular Dystrophies are rare but have major anaesthetic implications:

- Suxamethonium is absolutely contraindicated as it can cause potentially fatal severe hyperkalaemia.
- Most anaesthetists would also avoid volatile agents in these patients because of the concern of triggering Anaesthesia Induced Rhabdomyolysis (AIR). This is a condition similar to but not the same as malignant hyperthermia. A notable case report of a fatal case of AIR that occurred recently in Queensland is referenced below. Muscular Dystrophies are not associated with MH per se. Consequently these children warrant a TIVA which is challenging in itself. Ketamine and Propofol are both safe to use.
- They have cardiac abnormalities and significant muscle weakness including the respiratory muscles.

Lastly the following four syndromes are very rare but all are associated with very difficult airway management largely due to maxillofacial abnormalities:

- Pierre Robin
- Treacher Collins
- Goldenhar
- Arthrogryposis multiplex congenital

SELECTED REFERENCES

Fatal rhabdomyolysis following volatile induction in a six-year old boy with Duchenne Muscular Dystrophy. R Simpson and K Van. *Anaesthesia and Intensive Care* 2013 41(6): 8-5-7.

LIGHT RELIEF

ANAESTHESIA SUBSPECIALTY ALGORITHM

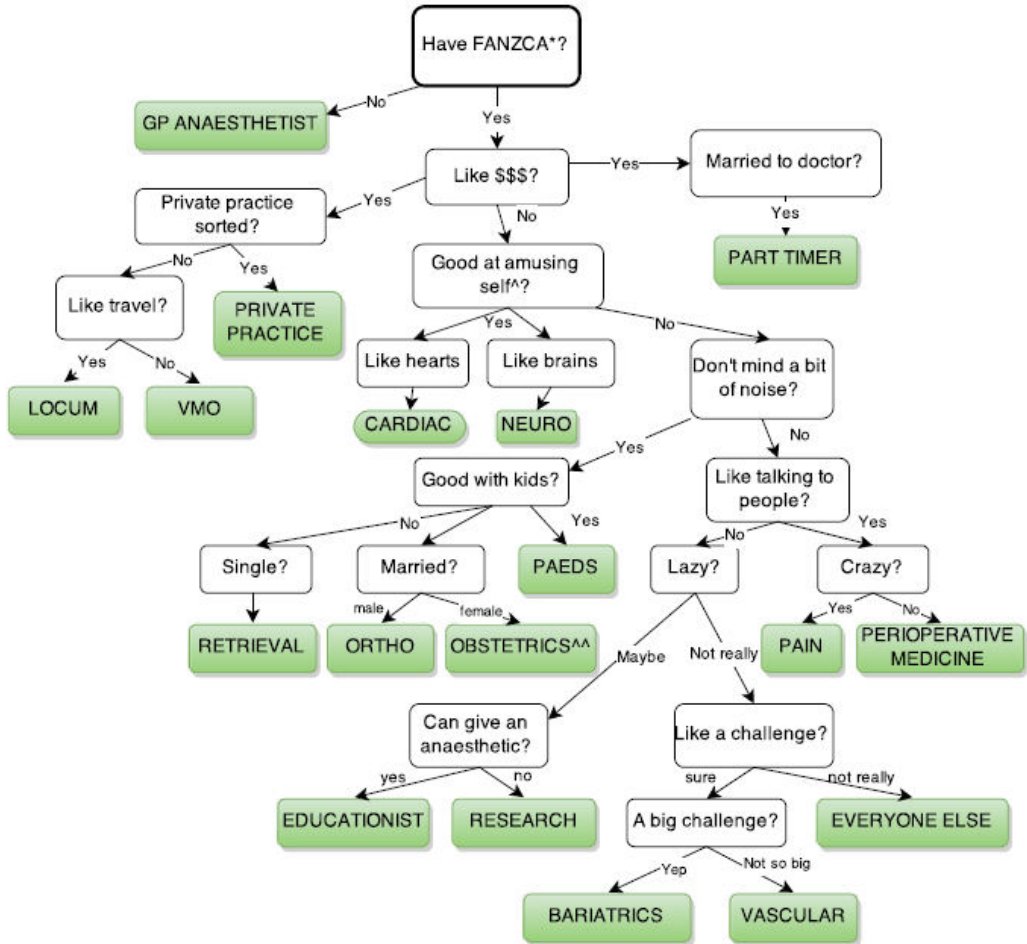

*Could also be termed 'Passed Primary?'

^^Alludes to long periods of boredom spent doing these cases hence the predilection for fiddling with the TOE probe in the former and amassing a plethora of syringe pumps in the latter

^^Honestly no one chooses to do Obstetrics

The Obese Patient

Everything is harder when the patient is obese

Obesity is the modern epidemic and there is no sign of it relenting. Obesity is undoubtedly the commonest co-morbidity you will have to contend with in your working life. By necessity you will get very good at managing morbidly obese patients. Quite a few years ago I coined the term NFT, 'Normal for Toowoomba', as a euphemism for the morbidly obese patient. The Darling Downs now has the unenviable mantle of being the most obese district in Australia, the second most obese nation on the planet. Two thirds of the adults in Queensland are overweight or obese. Simply telling massively obese patients they should lose weight before you will operate on or anaesthetize them is a futile exercise. The vast majority of patients will do the exact opposite and still end up having surgery. They should be referred for bariatric surgery- seriously. This chapter will succinctly navigate the following topics:

- The pathophysiology of obesity
- Pharmacokinetics in the obese patient
- Practical anaesthetic management of the obese patient

The Pathophysiology of Obesity

We will concentrate on the cardiovascular and respiratory systems and keep it brief. With increasing degrees of obesity there is an increase in blood volume, cardiac output and LVEDV. Although total blood volume is increased, adipose tissue is poorly perfused (20-30 mls/kg/min) and blood volume as a percentage of total body weight is reduced to about 50 to 60 mls/kg. Splanchnic blood flow is increased but renal and cerebral blood flow is normal. Obesity induced cardiomyopathy is an entity seen in the morbidly obese where the increased stroke volume causes LV enlargement and wall stress leading to LV hypertrophy and dysfunction. There is a high incidence of hypertension and exercise tolerance is generally poor. The increased oxygen consumption and ventilation requirements in combination with the decreased pulmonary compliance lead to increased work of breathing. Obese patients have a restrictive deficit demonstrated on spirometry. Both chest wall and lung compliance are reduced. Vital capacity is usually normal however FRC is reduced by compression of the dependent lung by the abdomen. FRC is dramatically reduced when the morbidly obese patient is supine, at least a forty percent reduction from the erect position, and this is low enough to be below the lung's closing capacity. Induction of anaesthesia further reduces the FRC. This causes ventilation perfusion mismatch and hypoxaemia. There is a high incidence of obstructive sleep apnoea (OSA) and if this is severe and untreated the classic Pickwickian syndrome of hypercarbia, hypersomnolence, pulmonary hypertension, polycythaemia and right heart failure results. Patients with OSA are very sensitive to CNS depressants and apnoeic events are more likely to occur in the perioperative period. The risk of respiratory depression is a major concern for the attending anaesthetist.

Other systems involved are the endocrine and gastrointestinal systems. Obese patients have impaired glucose tolerance and a high incidence of diabetes. They have increased intra-abdominal pressure and gastric volume but normal gastric emptying. They are more likely to

have hepatic steatosis, cholelithiasis and hyperlipidaemia. There is an increased risk of thromboembolic disease. All these abnormalities culminate in the anaesthetist being confronted with a patient who has little or no cardiac reserve, is prone to desaturation, will be more difficult to ventilate and is far more likely to suffer adverse cardiorespiratory events in the postoperative period.

Pharmacokinetics in the obese patient

These are altered primarily as a result of the changed body compartments. Hepatic and renal clearance are generally normal. Morbidly obese (MO) patients have increased total bodyweight (TBW) and lean bodyweight (LBW) compared to non obese people. While the increase in fat weight is relatively linear with increasing BMI, LBW increases are non-linear tending to plateau beyond a BMI of around 50. See the diagram below. Total body water, while increased, is reduced as a percentage of TBW compared to a non obese individual. Theoretically we should expect hydrophilic drugs to have a relatively preserved volume of distribution and lipophilic drugs to have an increased volume of distribution. Obese patients also have increased cardiac output and changes in regional blood flow which affect redistribution kinetics which is particularly relevant to anaesthetic induction drug dosing. LBW is the most appropriate dosing scalar for most anaesthetic drugs, excluding muscle relaxants.

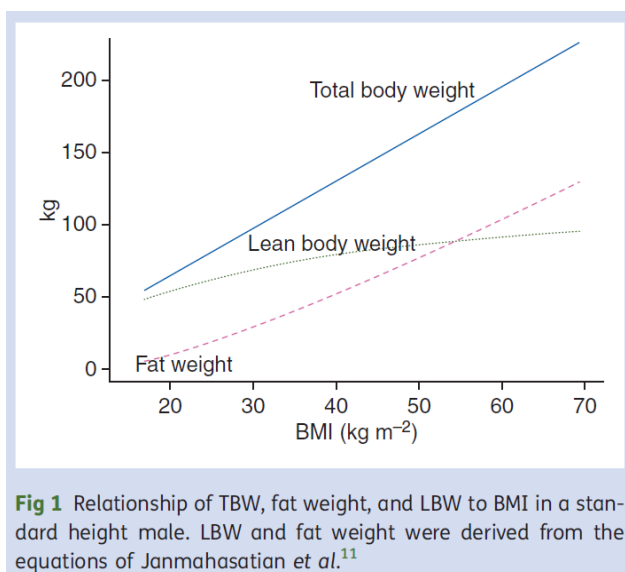

Figure from J Ingrande and H Lemmens. Dose adjustment of anaesthetics in the morbidly obese. *British Journal of Anaesthesia* 2010, 105(S1): i16-i23. Used with permission.

The majority of drug doses are based on the TBW of normal BMI individuals and so will tend to overdose MO patients. Ideal bodyweight (IBW), while easy to calculate, assumes all patients of the same height have the same LBW and so will tend to under dose MO patients. Most of the formulas will calculate an ideal bodyweight that is less than the actual LBW of a morbidly obese patient. The equations used to calculate LBW in MO pts are very complex and the ones incorporated into currently available TCI pumps are flawed. The considerable difficulties

encountered with using propofol and remifentanyl TCI in obese patients are discussed separately in *Everything you should know about Propofol TCI*.

The recommended dosing scalars for some important drugs are listed below:

Propofol induction- LBW (I can't resist and must say that the induction dose of a drug is enough to put them to 'sleep'.)

Propofol maintenance- TBW

Fentanyl- LBW

Suxamethonium- TBW (as recommended by clinical trials as opposed to what pharmacokinetic logic might suggest)

Rocuronium- IBW

Cisatracurium- IBW (In practice I use TBW otherwise I will be waiting a good four to five minutes before getting good intubating conditions. In this event your intubating dose of cisatracurium would be expected to last close to an hour.)

What does this mean in practice? It means for most drugs we shouldn't dose them on the patient's actual bodyweight but adjust them in some way. The formulas used to calculate IBW are simple but flawed as all are based on patient height. Some examples are:

$IBW_M = \text{Height in cm} - 100$; $IBW_F = \text{Height in cm} - 105$

$IBW_M = 50\text{kg} + 1\text{kg/cm height above } 150\text{cm}$; $IBW_F = 45\text{kg} + 1\text{kg/cm height above } 150\text{cm}$.

The validated LBW calculations are truly complex but a simplified version which I recommend is below. The reference is listed in *Selected References*. I acknowledge that these formulae are also based on height alone but they generate more reasonable numbers!

$LBW_M = 22 \times \text{Ht(m)}^2$ $LBW_F = 26 \times \text{Ht(m)}^2$

A couple of examples which are handy to consider are- an obese woman who is 165cm tall and an obese man who is 180cm tall both have a LBW of approximately 70kg. There is a 'normal' patient hiding inside.

Practical anaesthetic management of the obese patient

There are multiple guideline documents written regarding anaesthetic management of the obese patient. ANZCA does not have a document specifically relating to this topic but The Association of Anaesthetists of Great Britain and Ireland does. Queensland Health produced a document entitled *Anaesthesia: non-bariatric surgery in obese patients* that was an attempt to formalize guidelines for referral of obese patients from regional or smaller hospitals to a tertiary unit. A similar guideline for obese parturients was produced but the most recent edition abandons any attempt at making recommendations for transfer of patients. The surgical guideline 'suggests' referral for patients with a BMI exceeding 50 who are undergoing major surgery to have it in a tertiary centre. This guideline is ignored in practice largely because of no support from the tertiary centres for this recommendation. My hospital's cut-off for elective surgery is currently 180kg for non-obstetric surgery and a BMI > 60 for obstetrics. We deal with all the emergencies of course. The benefit of a tertiary centre is not for the anaesthetic expertise of course- regional anaesthetists arguably have more experience anaesthetizing morbidly obese individuals judging from our patient demographics. The benefit is that these centres have 24 hour on-site levels of staffing that can manage these patients safely out of hours. Tertiary centres don't have the same staff covering emergency surgery, obstetrics and intensive care simultaneously with inexperienced junior staff. They can comfortably run two theatres simultaneously out of hours.

No guideline document makes it any easier to anaesthetize a 200kg patient with necrotizing fasciitis at three o'clock in the morning. I will try and avoid extremes in the following discussion outlining practical considerations to take when anaesthetizing obese patients. They have been divided along conventional lines into preoperative, intraoperative and postoperative concerns. All anaesthetists would accept that every aspect of anaesthetizing an obese patient is more difficult.

Preoperative Management

- MO patients know they are obese and most are aware that they are at increased risk having surgery. This should be acknowledged and discussed frankly but empathetically.
- All MO patients should be screened for OSA. The STOP-BANG questionnaire is the best known and has been validated. A score of five or more is correlated with a high probability of moderate to severe OSA. If they have known OSA and have a CPAP machine they should be advised to bring it with them to hospital.

1. Snoring: Do you snore loudly (loud enough to be heard through closed doors)?	
Yes	No
2. Tired: Do you often feel tired, fatigued, or sleepy during daytime?	
Yes	No
3. Observed: Has anyone observed you stop breathing during your sleep?	
Yes	No
4. Blood pressure: Do you have or are you being treated for high blood pressure?	
Yes	No
5. BMI: BMI more than 35 kg m ⁻² ?	
Yes	No
6. Age: Age over 50 yr old?	
Yes	No
7. Neck circumference: Neck circumference >40 cm?	
Yes	No
8. Gender: Male?	
Yes	No

- Inquire about and document co-morbidities. Looking after their health is not a priority for some MO patients! If the patient smokes, has already had an infarct and is a diabetic then you can confidently ascribe them 'high perioperative risk' status.
- Carefully examine the airway. Most MO patients are not difficult to intubate unless they have other features to suggest this, for example reduced mouth opening or receding jaw. If they have a beard ask them to shave it off. It is unusual for patients not to comply with this request.
- Try and get an idea of their cardiac and respiratory function. Exercise tolerance is often difficult or impossible to assess on the basis of history. Have a low threshold to do an ECG, echo, ABG or spirometry as appropriate.

- Look at venous access and if you are considering neuraxial or regional anaesthesia then you should inspect the site and even consider doing a pre scan if you have a machine available in your clinic. Consideration of preoperative placement of a PICC line by the radiologists can make a world of difference if IV access is suspected or known to be challenging.
- Many anaesthetists would prescribe a PPI or ranitidine premedication.
- Consider if this patient needs a high dependency bed postoperatively and then book it. A MO patient with OSA having airway surgery needs an HDU bed.

Intraoperative Management

- It is inappropriate for an inexperienced, junior anaesthetist to anaesthetize a MO patient without direct supervision. Call your boss in after hours for these cases.
- Anticipate potentially difficult airway management and intubation. Although most are okay to intubate, bag mask ventilation is certainly not straight forward and the MO patient rapidly desaturates once apnoeic. If you struggle to bag them you already have a blue patient before you've even tried to tube them. Have appropriate sized guedels and a clear facemask with a good seal. Use a LMA if you are struggling while you are waiting for the cisatracurium to get around. You should have your favourite correct sized second generation device immediately available. A stubby handled laryngoscope is advisable and/or a Kessels blade so you can actually get the laryngoscope in their mouth for a start. Many anaesthetists would have a low threshold to use their favourite videolaryngoscope as their first line approach. This is perfectly reasonable. A LMA is generally inappropriate for the patient who is more than 120kg or so because the high airway pressures required to ventilate the patient adequately result in a leak. If in doubt, intubate. It is better to have a secure airway from the start as opposed to having to sort out a suboptimal supraglottic device when the surgery has started.
- Preoxygenate well but be aware this doesn't help if you can't ventilate. Consideration can be given to nasal cannula supplementing your facemask oxygen as well as applying some PEEP when pre-oxygenating. I use F_{iO_2} of 0.8 because 100% oxygen will cause significant absorption atelectasis even during the period of pre-oxygenation and this is of more concern to me than the negligibly increased oxygen reserve I get with pure oxygen.
- Special care with positioning and padding- this requires an adequate number of trained staff and proper equipment to facilitate correct care.
 - For induction the patient should be positioned optimally for intubation. Textbooks bang on about 'ramping' and creating mountains with pillows and towels and aligning the tragus with the sternal angle. There are dedicated commercial devices available for ramping that are expensive, cumbersome and difficult to remove once under the patient. I am a pragmatist and have intubated a lot of fat people. The vertex of the patient's head should be level with the top of the bed. A generous amount of reverse trendelenburg should be applied to encourage the breasts to sag downwards and to decrease the weight on their chest. There should be one decent pillow or two crappy pillows under the patient's head so their occiput is 10cm above the bed. Level them out once the ETT is secured.

- A hovermat is great to use but needs to be under the patient in the first place. If the patient is to be tilted during the procedure a hovermat must not be used because of the risk of them sliding off the table (I've seen it happen and it is not pretty). For a laparoscopic anything they should lie directly on the gelmat or table itself. No sheets of any sort should be left under the patient.
- (Un)fortunately most OT tables are rated to inordinately large capacities. Make sure your bed can have a 150kg patient perched on one end of it.
- Monitoring- have a low threshold for an arterial line; use an appropriately sized NIBP cuff. You may get a better reading if it is applied around the forearm.
- Oxygenating and ventilating your patient adequately is the priority so if they have a pneumoperitoneum and are in the trendelenburg position and they have raised airway pressures then you need to ensure the patient is not being compromised. Ensure the tube position is okay, adjusting ventilator settings (I usually change the I:E ratio from the default 1:2 to 1:1) may facilitate a reasonable compromise.
- Don't forget about thromboprophylaxis- both mechanical and chemical. TED stockings and SCuDs need to be of the correct size.
- You may need a long needle if you are performing regional anaesthesia but this is actually rarely necessary.
- Extubate the patient awake with them sitting up to promote adequate ventilation. Do not move the patient from the table to the bed when they are light. Keep them asleep and only waken them once the transfer has been completed. The last thing you want is to have a combative 150kg patient trying to fall off the bed.
- Use the NMT if you used muscle relaxants and make sure they are adequately reversed.

Postoperative Management

- You are particularly worried about respiratory depression as previously discussed. Supplemental oxygen therapy does not treat OSA or respiratory depression, it masks it. CPAP does treat OSA but if this is not available or feasible (nose full of packs after their FESS for example) then the patient needs to be monitored appropriately. Often a high dependency unit is the only safe option.
- Patients usually declare themselves in PACU. The patient who is somnolent, having apnoeas and desaturating off oxygen is going to be a MET call on the ward later on.
- Incentive spirometry, chest physiotherapy and aggressive thromboprophylaxis should be the norm after major surgery. You need to help facilitate this.

SELECTED REFERENCES

High STOP-Bang score indicates a high probability of obstructive sleep apnoea. F Chung et al, *British Journal of Anaesthesia* 2012, 108:768-75.

Dose adjustment of anaesthetics in the morbidly obese. J Ingrande and H Lemmens, *British Journal of Anaesthesia* 2010, 105(S1): i16-i23.

Just a little oxygen to breathe as you go off to sleep...is it always a good idea? A Lumb editorial.
British Journal of Anaesthesia 2007; 99: 769-71.

SWAPNET. Anaesthesia: non-bariatric surgery in obese patients. Document Number QH-GDL-395:2013. Accessed from Queensland Health website.

Maternity and Neonatal clinical guideline. Obesity in pregnancy. Document Number MN15.14-V5.R20. Published December 2015. Accessed from Queensland Health website.

Simplified estimation of ideal and lean body weights in morbidly obese patients. M Carron et al.
British Journal of Anaesthesia 2012; 109: 829-30.

CHALLENGE QUESTIONS

This is more a bit of trivia for you. The two fattest patients reported in the literature to have been anaesthetized weighed 445kg and 510kg respectively. The first was a twenty-two American male who was intubated to facilitate ventilation for respiratory failure. The second was a twenty year old Saudi male who underwent bariatric surgery. When he was 'admitted' to hospital via forklift he was the fattest human in the world at 610kg. After four months of dietary therapy he lost a hundred kilograms and had a BMI of 187.

How would you have secured their airways? What grade laryngoscopy were they? I will reveal how they were managed on the following page.

'ANSWER'

I can't think of a sensible option other than to do an awake fiberoptic intubation on a patient as huge as this. Trying to mask ventilate someone that big must be presumed to be very difficult. An LMA would be a struggle for the predicted high airway pressures that would be necessary to facilitate adequate ventilation. A surgical airway would be diabolically difficult. The American man had 20cm of adipose tissue overlying his trachea! No cannula can traverse that. Both patients were assessed as having expected difficult airways. Both were subsequently found to have Grade 1 direct laryngoscopic views. Surprisingly, neither of them had their airway secured by awake fiberoptic intubation.

They attempted awake oral fiberoptic intubation on the American chap but failed because of 'poor patient cooperation'. He was obtunded courtesy of respiratory failure. An attempt at nasal awake intubation was abandoned courtesy of bleeding precipitated by a nasopharyngeal airway. They placed a size 5 Proseal LMA under topical anaesthesia; induced anaesthesia with Sevoflurane and then placed an Aintree catheter with bronchoscopic guidance. Finally a tube was railroaded over the Aintree.

The management of the Saudi man makes even more interesting reading. He was induced with 350mg of propofol and 200mcg of fentanyl and then 'after confirming that mask ventilation was feasible' they gave him 80mg of rocuronium and intubated him with the Glidescope. You can watch a video clip of the actual intubation. They comment that they had ECMO on standby but he had no access in situ to hook this up to so presumably he would have died before they had that working in the event of inability to get an airway.

Airway management in a 980-lb patient: use of the Aintree intubation catheter. D Doyle et al. *Journal of Clinical Anesthesia* 2007; 19:367-9.

General anesthesia for the heaviest man in the world. A Terkawi et al. *Saudi Journal of Anaesthesia* 2014; 8:101-4.

A few words about endoscopy

Good sedation is harder to do than giving a GA

Upper endoscopy is the most commonly performed procedure in Australia requiring anaesthetic services. Gastroscopy and colonoscopy combined account for a huge portion of the health budget and account for a large amount of the procedural activity in both private and public hospitals. For many GP anaesthetists, endoscopy accounts for the majority of their practice. It is appropriate then to make some comments about this subject. Endoscopy related incidents feature prominently in surgical mortality reports. As the quote above says it is actually more challenging to sedate a spontaneously breathing patient who is having a scope stuck down their throat than it is to simply stick a LMA down and flip them onto the ventilator. Like everything else in this world, the more scopes you do the better you get at doing them.

ANZCA has a document defining the minimum monitoring and staff requirements for patients undergoing procedures under sedation. If an anaesthetist is present then they should have a dedicated person available to assist them. Preferably this is an anaesthetic assistant but this is not always the case. By definition most patients aren't receiving sedation but they are undergoing a short general anaesthetic as they are unconscious and unresponsive for the majority of their procedure. (My patients are, anyway.) The patient must not go home alone. They must be discharged into the care of a responsible adult. They can't drive for 24 hours because if they have a car crash the next day their insurance won't cover them.

Anaesthesia for gastroscopy 101

- Put the IV in the right arm preferably as the patient will be on their left side and it is easier to access their right arm rather than having to reach across the patient.
- Remove all dentures complete or partial before you make them sleepy.
- I place a pillow behind their back for comfort and to stop them rolling back my way. Their right arm is resting on their hip with their legs slightly bent.
- Local anaesthetic spray tastes truly disgusting and does not confer any benefit unless the patient is having this procedure with no intravenous sedation at all.
- Patients who have been smoking on the day of the procedure should have their procedure cancelled. They will give you grief otherwise.
- Have the sucker turned on and placed underneath the pillow.
- Once the bite block is in place someone (not you) needs to make sure it is not expelled by the patient. Broken teeth and endoscopes are both expensive items to repair.
- Propofol is all you need for gastroscopy. Midazolam, if used, needs to be given several minutes prior otherwise there is no point in giving it. See *Planning the anaesthetic*.
- Don't give the white stuff until the proceduralist is actually holding the scope and ready to go. Timing is of the essence. You need to give a reasonable slug of propofol so the patient doesn't protest when they are 'intubated' by the proceduralist yet you are reliant on a degree of stimulation by the process to encourage the continuation of respiratory activity.

A little old lady only needs 2 or 3 mls and patience and a healthy young man will usually need closer to 100mg of propofol.

- Once the scope is in the stomach minimal additional drug is required.
- If the patient coughs and gags a lot and the scope isn't down then have them pull out and let the patient settle down before trying again. If the scope is down then support the airway with jaw thrust and be patient. Almost always they settle down.
- The overwhelmingly vast majority of patients don't remember anything about their procedure. This is courtesy of the propofol.
- A skilled endoscopist should be able to perform a gastroscopy with almost no sedation. This informs the adage that 'anyone can have a gastroscopy'.

Anaesthesia for colonoscopy 101

- Draw up some ephedrine. The commonest haemodynamic disturbance encountered during a scope list is hypotension and bradycardia due to a combination of propofol and vagal stimulation due to bowel distension. Ephedrine is the logical vasopressor to use as well as telling the endoscopist to back off before asystole results.
- Put the IV in their left arm preferably as it is closer to you and easier to apply the NIBP on the upper arm and fix it when it misbehaves.
- They don't need IV fluids. This has been studied and there is no benefit with the practice. Modern bowel prep solutions 'flush', they don't 'suck' fluid from the patient. How dehydrated they are is a product of the fasting protocol. Bowel prep can be considered as a clear fluid for fasting purposes but it does not hydrate the patient.
- The dentures can stay in.
- A Hudson mask with a connector for the capnograph is nice. You should be able to tell if your patient is breathing or not without the benefit of a capnograph, though.
- Again propofol is the only drug you need to get the job done. It is also the drug that gets you into trouble. You can use propofol TCI if you like and you will discover that you are often giving 'general anaesthetic equivalent' doses of propofol. I would argue that giving small amounts often is safer than a syringe pump that is continually administering white stuff regardless of what is happening to the patient. Many practitioners would argue the contrary. Midazolam will reduce propofol requirements and possibly 'smooth' things out. I use fentanyl as colonoscopies are uncomfortable and I don't have problems with it.
- Colonoscopies follow a predictable course: usually a PR is performed first and this is quite stimulating so make sure the patient is appropriately groggy before you let the endoscopist start. This requires 2mg of midazolam, three minutes to elapse, 0.5mg/kg of propofol and a further thirty seconds to elapse. If they don't say anything when you say "how are you going there?" they are good to go. I often say "We're going to start now" as a cue for the proceduralist to start. Negotiating the sigmoid colon is often tricky and this is where most of the discomfort is generated. If a loop has formed and the proceduralist is running out of scope often external pressure is required to help negotiate the loop. This is stimulating and I often say, "some pressure on your tummy now, *insert name here*". Once they have got to the end- getting in the terminal ileum is the only 100% reliable way of determining this- then the patient requires minimal sedation on the way out. I still trickle in some propofol as I don't want the patient waking up and rolling over on top of the proceduralist as they are

trying to take a polyp off. At the end many endoscopists will do a 'J' and inspect the distal rectum. This is also stimulating.

- Be wary of the patient who is hiccupping, swallowing a lot or profusely salivating- this is a prelude to regurgitation.
- If the patient is obstructing, jaw thrust should be all that is required to relieve it. I prefer to do this and not have the assistant do it as it makes me stop giving white stuff and pay appropriate attention to my patient.
- You should be able to recognize the caecum as reliably as a gastroenterologist. You will be glad to see it. Visualizing the ileocaecal valve from afar does not constitute an adequate examination of the colon.
- Everyone shares the 'polyp spotting' duties.
- A colonoscopy should take about 15 minutes or so to do and you will expect to have used about one ampoule of propofol.
- If the patient is having a combined gastroscopy/ colonoscopy, known as a double ender, they should have the gastroscopy first. This way at least you know that the stomach is empty.

ERCPS

- They are just horrible and a detailed description of their management is beyond the scope of this book. They are usually performed with the patient in the awkward 'Swimmer's' position which is a mostly prone position. Many practitioners would give a GA with an ETT for this procedure.

Crises in a Nutshell

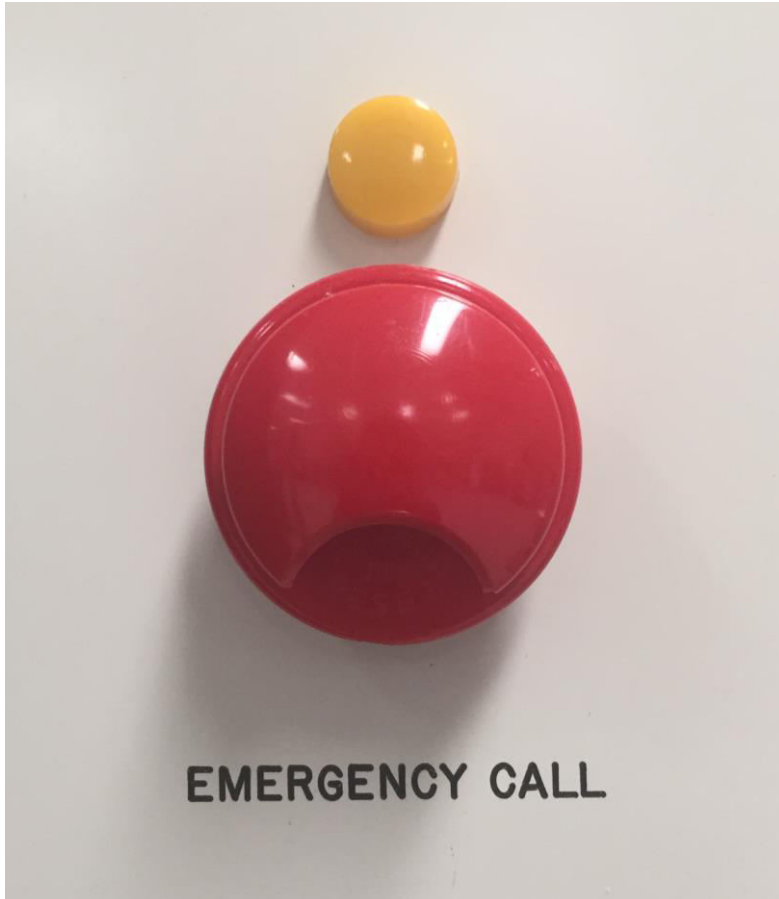

The big red button

Difficult Airway 101

Airway trumps everything

Much of the content for these next chapters comes from the *Anaesthetic Emergencies Handbook* which I wrote. Originally written for my hospital and the people who worked in it, I produced a generic version a few years ago which has been well received. The Handbook is revised annually and is of a standard that would adequately prepare you for the final fellowship examination. Difficult airway management rightly gets pride of place in that book as well as in this section on anaesthetic crises. This is somewhat of a misnomer as the intention of the anaesthetist is to avoid getting into a crisis situation in the first place. We are expected to be the airway experts and to be competent and technically proficient in all forms of airway management. Anyone can manage the easy airway, it is the difficult one that anaesthetists are expected to also master.

The following topics will be discussed:

- Recognizing the difficult airway
- Formulating a management plan
- Equipment to manage the difficult airway
- The failed intubation drill
- CICO- the Heard approach
- Some thoughts about awake fiberoptic intubation

I won't discuss difficult paediatric airway management. That is a specialty topic beyond the scope of this book. As already mentioned, most children have easy airways.

Recognition of the difficult/ threatened airway

- Principally this entails taking a history and performing a physical examination. Don't forget to document an "Anaesthetic Alert" if you suspect difficult airway management when you see a patient in Preadmission Clinic.
- Investigations that can be helpful include:
 - CT scan neck/ chest to assess airway compression/ distortion especially with neck and mediastinal masses
- Nasendoscopy- best for supraglottic/ glottic lesions. This is usually performed by the ENT team and will be documented in the OPD notes. Comments on the view and whether the cords are mobile are what you are interested in.
- Don't forget to look at previous anaesthetic records- these are your best source of information. At least look in AARK.
- Historical elements that should concern you include:
 - Known Hx difficult intubation
 - Hx cervical trauma/ surgery eg. fusion.
 - Hx previous neck surgery/ radiotherapy
 - Hx of night panics/ positional related airway obstruction.
- Physical signs that suggest a difficult intubation are poorly predictive if only one sign is present but in combination are more reliably suggestive of potential difficulties. A reduced

thyromental distance is of particular concern. A full set of immaculate teeth should worry you whereas a set of dentures should have the converse effect. The morbidly obese patient will predictably be difficult to bag mask ventilate and will poorly tolerate failed or repeated attempts at intubation because of their severely reduced respiratory reserve. See *The Obese Patient*.

- Recognize that predictors of difficult intubation are different from those for difficult mask ventilation, although there is overlap. A handy acronym to remember factors that predict difficulty in mask ventilation is OBESE: Overweight, Beard, Elderly, Snoring, Edentulous. Think of Santa Claus and you are mostly there.
- Signs of a threatened airway:
 - Any signs of obstruction - suprasternal and intercostal recession, stridor (may be absent or very quiet in a patient at rest), pooling of secretions, patient sitting up and unable or reluctant to lie flat, dysphagia, tachypnoea, signs of sympathetic stimulation (anxiety, tachycardia and hypertension.)
 - Dire signs are- silent chest and obtunded patient (patient has expended their sympathetic drive), fatigue (hugely increased work of breathing) and hypoxaemia despite supplemental oxygen.
- It is better to 'over predict' difficulty than 'under predict' it.

Formulating a management plan

- Assessing the patient as above is the vital first step in formulating a plan.
- If you think it will be difficult call for senior/ experienced help. An experienced ENT surgeon is invaluable help.
- Prepare your equipment and drugs. This includes your anaesthetic assistant knowing what your concerns are and plan to manage them. We will talk about the equipment in detail below.
- Formulate a primary (Plan A) and secondary plan (Plan B) considering the following factors:
 - Anatomical level of the lesion- is it oral/ supraglottic, laryngeal or below the larynx?
 - Can the patient open their mouth wide enough to get a LMA/ laryngoscope in there?
 - Will they be compliant with an awake intubation?
 - What is the degree of airway obstruction or compromise?- how much time do you have, can the patient lie flat?
 - Is there a risk of airway soiling from pus, blood or gastric contents? Are they an aspiration risk?
 - Are you able to get surgical access to the trachea and if so is it likely to be difficult?
- Other considerations are:
 - Does the patient require general anaesthesia? Eg. The patient with atlantoaxial instability for lower limb surgery may be appropriate to do with a spinal.
 - Does the patient need to be intubated? Is it reasonable to do the case with a LMA? -beware if aspiration risk or anticipated difficulty ventilating the patient

esp. the obese patient. ***Elective use of an LMA solely to avoid intubating a suspected difficult airway is unwise:*** airway management may be even more difficult in the event of failed LMA insertion.

- Is bag mask ventilation likely to be difficult? If so it may be prudent to secure the airway prior to inducing anaesthesia.
- *What techniques am I familiar and experienced with?* An airway emergency is not the time to use a technique or piece of equipment for the first time (unless you are doing a surgical airway!).

General comments

- Practise and be familiar with your airway drills. The Failed Intubation Drill is discussed in detail below.
- The KISS principle (Keep It Simple Stupid) should inform your drills and plans. The brain doesn't work so well under pressure.
- Practise using various airway devices and techniques on elective cases under supervision. Airway management is one of the clinical fundamentals and you are learning to be proficient in their management. It is in everyone's best interests that you are familiar with the equipment available in your local environment.
- Be prepared- don't forget what Plan B is again. Satisfy yourself that your assistant appreciates your concerns and is as prepared as you are.
- Have a low threshold to bring the difficult intubation trolley into theatre. It lets the rest of the personnel know that this is not a straight forward case and quietsens the theatre banter.
- Failed intubation doesn't kill- failed oxygenation and ventilation does. Don't forget the option of bailing out early and waking the patient up.
- Ensure secure IV access before you start- this includes paediatric patients.

Pros and Cons of some techniques for difficult airway management

- AWAKE TRACHEOSTOMY UNDER LA

Pros:

- The 'Gold Standard'- a definitive airway is secured without the need for sedation or impairing the patient's protective reflexes.
- Indications:
 - Patient with stridor at rest, eg. Neck trauma, supraglottic/ glottic tumour
 - Patient who can't open their mouth- trismus, jaw problem.

Cons:

- Takes time.
- Need cooperative patient.
- Need experienced surgeon available to do the procedure.
- Difficult to do with patient sitting up; really need them to lie flat.
- Relatively contraindicated if field is contaminated, eg. Local sepsis, infiltrating tumour, papilloma.
- Doesn't help if the obstruction is distal to proximal trachea.

- AWAKE FIBREOPTIC INTUBATION

Pros:

- Patient maintains spontaneous respiration, able to abandon procedure safely.
- Allows visualisation of entire airway to level of the bronchi.
- Good technique for lesions that impede intubation but not gas flow.
- Indications:
 - Known/ suspected difficult intubation (not all cases)
 - Cervical spine trauma
 - Patient who can't open mouth.
 - Oral or supraglottic lesion.
 - Mid tracheal lesions, eg. Goitre.

Cons:

- Need cooperative patient.
- Requires excellent topical anaesthesia ± sedation. Inadequate airway anaesthesia results in coughing/ bucking and difficulty performing the procedure.
- Can be technically difficult to do, need to practise this skill on a regular basis so when you really need it- it works.
- Relative contraindications:
 - Critical upper airway obstruction.
 - Bleeding/ friable lesions or the presence of pus/ secretions makes this technique very difficult to perform.
 - If tracheal narrowing is suspected then a bronchoscope may worsen the obstruction- 'cork in a bottle'.
 - Gross airway abnormalities.

- GAS INDUCTION

Pros:

- Provides anaesthesia
- Favoured technique for paediatric cases.
- Maintenance of spontaneous respiration allows you ability to bail out if encounter difficulty (theoretically- loss of airway leads to lightening of anaesthesia).
- Facilitates performance of surgical airway if able to maintain airway but unable to intubate it.
- Avoidance of application of positive pressure ventilation.
- Indications:
 - Favoured technique for inhaled foreign body- avoid IPPV and pushing the foreign body further down.
 - Lesions at the level of the cords or below (mediastinal mass, bronchopleural fistula).

Cons:

- Can be difficult to achieve adequate depth of anaesthesia particularly with an obstructed airway.
- Should not be first option if anticipate difficulty with mask ventilation

- Possibility of airway loss (worsening of obstruction) and loss of ventilation (apnoea, breath holding) remains.
 - Difficult to perform with a patient who has severe airway obstruction or a patient who can't lie down- induction may lead to loss of airway.
- LARYNGEAL MASK AIRWAY
 - Pros:
 - There are several places where the LMA can be used in the management of the difficult airway:
 - Elective use as airway device to perform case.
 - Elective use as conduit for intubation- fibreoptic or blind (eg. Intubating LMA has a better success rate than Classic LMA.)
 - Emergency use (failed intubation) as conduit for intubation. The Ambu LMA is favoured in this instance.
 - Emergency use to obtain airway and as a ventilatory device.
 - Familiarity with use and efficacy in obtaining a quality airway.
 - High success rates reported in emergency situations both to obtain an airway and as a ventilatory device. There is a wealth of literature to support its use.
 - Remarkably versatile- *the LMA saves the day in the majority of cases.*
 - Cons:
 - Doesn't protect airway against aspiration. Correct placement isn't possible when cricoid pressure is applied.
 - Ventilation may be inadequate where high airway pressures are encountered, eg. Obese patient, poorly compliant lungs, bronchospasm. A second generation device is the preferred option. Expert opinion from the British Difficult Airway Society favours the iGel.
 - Requires an amount of mouth opening- minimum interdentine distance of 25mm.

Equipment to manage the difficult airway

Every hospital that provides anaesthetic services has a difficult airway trolley. ANZCA has a nice document that details what equipment should be present on that trolley. Every anaesthetist should be familiar with each piece of equipment that is on their hospital's trolley. I will not exhaustively go through the list but have made comment about most of the items below. Surgical airway equipment will be dealt with separately. Even in the 21st century the humble bougie retains pride of place as the device that will still get you out of trouble most of the time. Undoubtedly the most significant change in difficult airway management in the last decade has been the enthusiastic adoption of videolaryngoscopes. Both these devices deserve some more detailed comment than the rest.

- Bougie- the ideal bougie is not too floppy or slippery and of an adequate length. If it has a nice kink at one end and is hollow to facilitate the insufflation of oxygen then you have a good bougie. The Frova is the only device that ticks all these boxes. The commonest application of the bougie is the situation where you can see the glottis or have a very good idea where it is (behind the epiglottis) but cannot negotiate the tube between the cords. The technique of railroading the tube over the bougie once it is in the trachea is as follows:

leave the laryngoscope in, the assistant holds the end of the bougie while you advance the tube. If it doesn't pass easily, rotate it ninety degrees anti-clockwise so the bevel of the tube faces anteriorly. Excessive force just traumatizes the airway.

- Videolaryngoscopes (VL)- all these devices are useful for the commonest difficult intubation scenario where, with direct laryngoscopy, you can't visualize the glottis well. You can't 'see around the corner', this is also termed the 'anterior' larynx. VLs enable you to 'look around the corner' and commonly give you an excellent view of the glottis. They do not ventilate the patient however and often negotiating the tube can be tricky and often requires the use of the bougie. I have some notes about the three VLs that my hospital has, they all have their pros and cons.
 - C-Mac- has a series of blades that must be autoclaved after use that are connected to a free-standing video monitor. The 3 and 4 blades function effectively the same as the equivalent conventional Macintosh blades. It is a good teaching tool as everyone can see what you see. The D-blade for 'difficult' intubations has the typical 'hockey stick' configuration and invariably requires a bougie or stylet in the tube to direct it into the glottis while you are looking at the monitor.
 - Pentax AWS (Airway scope)- VL with fiberoptic light source and is an all-in-one device with the monitor on the top of the device. Requires the use of single use PBlades which come in adult and paediatric sizes. You must look at the monitor when using this device. Insert the plastic blade a bit like a supreme LMA by rolling it in, lift up the epiglottis with the tip of the blade and align the glottic opening with the green target which is superimposed on the screen. The Pentax is a channelled VL which means you preload the lubricated ETT on the device and simply advance the tube once you have aligned it. This avoids the need for bougies and frustrations with getting the tube to go where you want. It is relatively bulky, however.
 - King Vision- a VL that is channelled and similar to the Pentax but the image quality and the screen are not as good. It is a much cheaper device, however.
- Intubating LMA- also known as the Fast-track. This device has a sizeable wealth of clinical experience behind it in terms of managing difficult airways but has largely been superseded by VLs. They come in various sizes (3, 4 and 5) and have a dedicated ETT for use with them which has a rounded end. The tube must be well lubricated prior to use and inserted several times into the device before use. The ETT can be inserted blindly as was its original intent or with the aid of a bronchoscope. Requires slightly greater interdentine distance than a standard LMA to allow insertion. It is a very rigid device and the ability to ventilate the patient just with the LMA must first be determined before making attempts to intubate the patient.
 - Potentially useful for patients:
 - with cervical spine problems who require intubation as minimal neck movement is required.
 - Who are a known/ anticipated difficult intubation with adequate mouth opening and ventilation is not expected to be difficult.
- McCoy blade- has a lever attached that elevates the tip of the blade to facilitate lifting up the epiglottis. Mostly helpful with some Grade III laryngoscopic views where the epiglottis is mobile enough to be moved out of the way.

- Long straight blade (Miller) and short handled laryngoscope- The Miller blade has limited applications. It requires a different technique and it is easy to damage teeth with this thing. It is classically described in association with the paraglossal technique with placement of the blade under the epiglottis and lifting it up. It is thought to be helpful where there is limited room for the epiglottis to be elevated. The stubby handle and the angled blade or Kessels blade enable insertion of the laryngoscope where breasts or obesity impede access. Another option is to remove the blade from the handle, insert the blade and then reconnect it to the handle.
- Airway Exchange Catheters- for use when exchanging an in situ ETT for another ETT (eg. Converting a reinforced ETT to a conventional ETT), especially if it was a difficult intubation in the first place. They are hollow and have an adapter enabling connection to a standard circuit so you are able to ventilate with them. *You must never insert an airway exchange catheter more than 23cm past the lips.* You run the risk of causing major airway trauma of which I unfortunately have had firsthand experience.
- Extubation kit- this is a commercial device that essentially consists of a soft wire and a dedicated single use airway catheter. The wire can be left in situ in the extubated patient and used as a conduit for railroading the airway catheter in the event that re-intubation is required.

Other airway equipment items not kept on the trolley

- Fibreoptic Bronchoscope
 - The use of this device in awake fibreoptic intubation is discussed below. The amount of paraphernalia that accompanies these expensive tools usually necessitates them being kept on a dedicated trolley.
- Ambuscope
 - A single use bronchoscope. Doesn't have suction channel and the image quality not as good as a regular bronchoscope.
 - Connected to a dedicated video monitor on stand.
 - Appropriate for elective cases only where there is no blood or pus or mucus (yet).
- Rigid bronchoscope: ENT cases.
 - This device may be lifesaving. The surgeon may be able to obtain an airway with it when your attempts have failed and you are about to perform a surgical airway.
 - Bleeding tonsil- the rigid bronchoscope should be available in the OT.
 - Mediastinal mass/ tracheobronchial pathology- because the scope is rigid it acts as a stent and can facilitate ventilation when all other attempts have failed.
- Heliox
 - 28% O₂, 72% Helium gas mixture stored in a large cream coloured cylinder.
 - May 'buy you time' when managing a patient with stridor- can decrease the work of breathing and may improve oxygenation.
 - O₂ tubing can be connected directly to the cylinder.
 - Fixed O₂ content may limit its usefulness in a hypoxic patient.
 - Other options to be considered to reduce airway swelling while making preparations for definitive management are:
 - Adrenaline Nebbs

- Antisialagogue: Glycopyrrolate 400mcg IV
 - Dexamethasone- this will take hours to have any effect.
- Jet ventilator
 - Requires training and familiarity in its use. Most common application is for the narrowed airway, eg. Tracheal stenosis.

The Failed Intubation Drill

- Airway Algorithms- there is a plethora of algorithms and ‘cognitive aids’ vying for the attention of the trainee anaesthetist. Not uncommonly these adorn difficult airway trolleys and crash carts. Arguably the most recognizable algorithms in Australasia are those of the British Difficult Airway Society (DAS). The American algorithm is a cluttered mess. The Vortex is an example of a cognitive aid and it was formulated by an Australian anaesthetist and an emergency physician. I have reproduced the DAS algorithm for unanticipated difficult intubation and the Vortex more for the sake of completeness than an expectation for you to remember them. When an actual crisis is happening no one is looking at them of course! Their real value is as a training tool. Remember the KISS principle.
- Basic Airway Algorithm- this has four elements which we will consider in turn:
 - 2 attempts at intubation and changing something between each attempt
 - Best attempt at bag mask ventilation (BMV)
 - Use of LMA as rescue airway
 - Surgical Airway if all above fails
- See also the algorithm for Failed Intubation LSCS in *Obstetric Anaesthesia*.
- Intubation attempts using direct laryngoscopy-
 - Start with your patient in optimal position- this does not mean shoving three pillows under their shoulders.
 - Avoid prolonged and repeated attempts- this causes airway trauma and makes matters even more difficult, the priority is oxygenating the patient.
 - Use BURP- this will usually improve your view by one grade but it can further distort your view if applied poorly however. Consider placing your hand over your assistant’s to adjust external laryngeal pressure and optimise your view.
 - Have a low threshold to use the bougie, particularly if you can see the glottis but are having difficulty passing the ETT.
 - Change something between attempts- size of blade, VL if handy, a more experienced operator if available.
- Best attempt at bag mask ventilation-
 - The incidence of true impossible mask ventilation is generally quoted at 1 in 10,000. This is pretty damn rare but assumes that an experienced practitioner is at the helm.
 - A ‘best attempt’ entails-
 - Optimal head and neck position with the neck flexed and the head extended.
 - Appropriately sized facemask and oropharyngeal airway.

- Two-handed ventilation with assistant squeezing bag (APL valve closed and high FGF).
 - Maximal jaw thrust- applied by an assistant if necessary (3rd pair hands).
 - Use of bilateral nasopharyngeal airways- the problem with NPAs is they are great for precipitating epistaxis and blood in the airway is not a desirable feature.
 - Muscle paralysis- relaxant makes ventilation easier.
 - This is why you should take advantage of every opportunity to practise this invaluable skill.
- Use of LMA as rescue airway-
 - This almost always works, thank the good Lord. It buys you time at a minimum and makes the option of waking the patient a lot more feasible. Again a second generation device is preferable and cricoid pressure should be released to facilitate placement.
 - If you haven't already paralysed the patient and you've got to this stage then you should be giving a muscle relaxant. Nothing works as quickly or reliably as suxamethonium.
- Surgical Airway-
 - The Heard algorithm is presented below.
 - You should know how to do a surgical airway if you had to. You need to be familiar with the equipment available in your theatre environment. If an ENT surgeon is in the room they should be doing this!

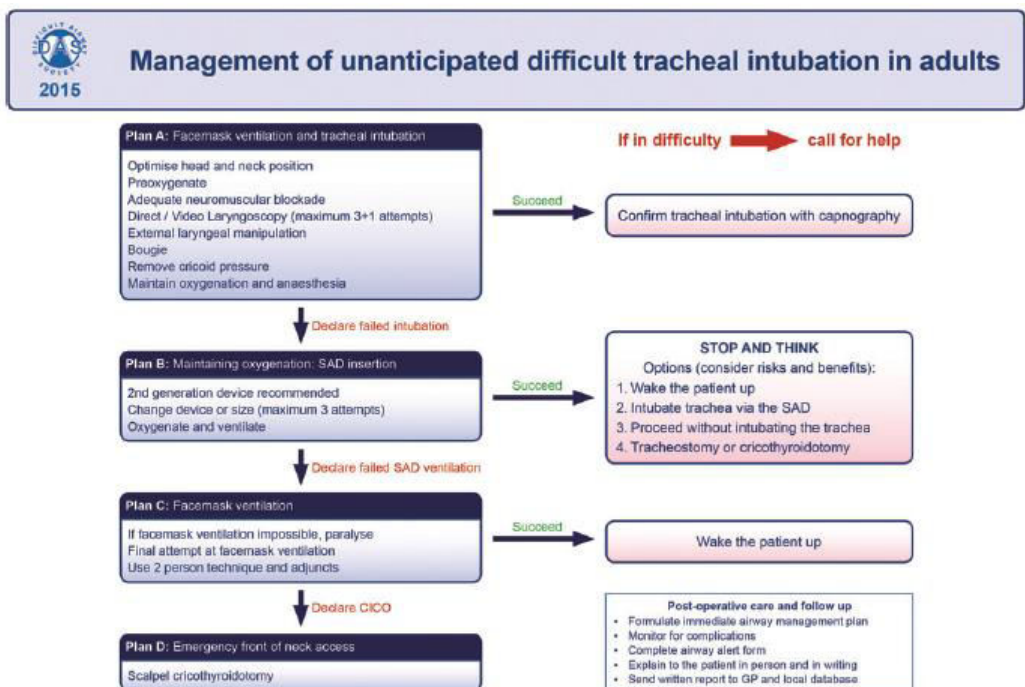

The Vortex

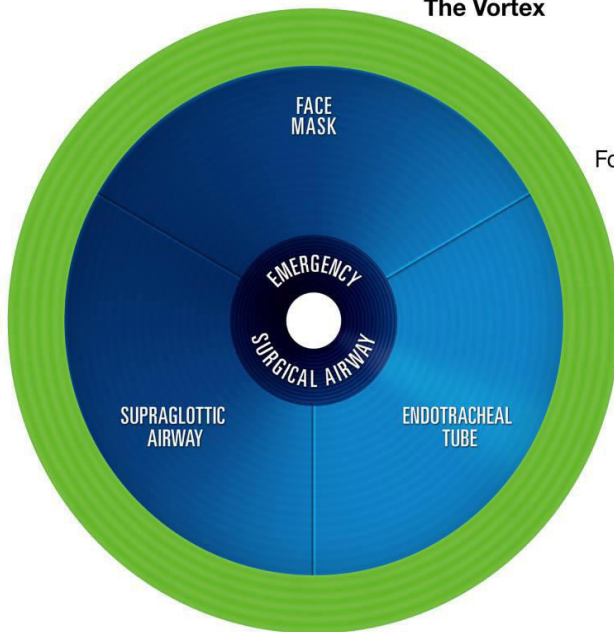

For Each NSA Technique Consider:

1. Manipulations:
 - Head & Neck
 - Larynx
 - Device
2. Adjuncts
3. Size/Type
4. Suction/O₂ Flow
5. Muscle Tone

**MAXIMUM THREE TRIES AT EACH NON-SURGICAL AIRWAY TECHNIQUE
AT LEAST ONE TRY SHOULD BE HAD BY MOST EXPERIENCED AVAILABLE CLINICIAN**



CICO- the Heard Approach

Andrew Heard is an anaesthetist based in Perth. He published his Surgical Airway algorithm in *Anaesthesia* in 2009. This was borne from extensive experience running a ‘wet lab’ simulation course for surgical airways for anaesthetists using anaesthetized sheep. This course has been replicated in other centres across Australasia. His group have the most experience of any training organization in the world of teaching anaesthetists how to obtain and secure a surgical airway in a high fidelity, stressful situation. The Heard approach very much champions the cannula first approach and is an approach tailored for anaesthetists. All the components of the algorithm are clearly demonstrated on a series of YouTube clips that are freely accessible and I commend them to you. Most anaesthetists, and I include myself in this cohort to date, will never be confronted with a genuine CICO situation. We should all know what to do if we are.

It would be negligent of me not to make the point that sugammadex has no role in the CICO scenario. If you truly cannot ventilate or oxygenate your patient that has been paralysed with rocuronium or vecuronium (or suxamethonium for that matter) then giving sugammadex will not help- they will be dead. Your priority is to oxygenate the patient. Sugammadex will reliably antagonize the relaxant but this is done only after you have oxygenated the patient and secured the airway. Benumof published a classic article demonstrating that a properly pre-oxygenated patient if given a paralyzing dose of suxamethonium will still desaturate to critically low values before ‘functional recovery’ from the sux has occurred. Although you might be able to antagonize rocuronium with sugammadex in less time than it takes for sux to wear off, in the real world you don’t inject an amp of roc and follow it *immediately* with three of sugammadex!

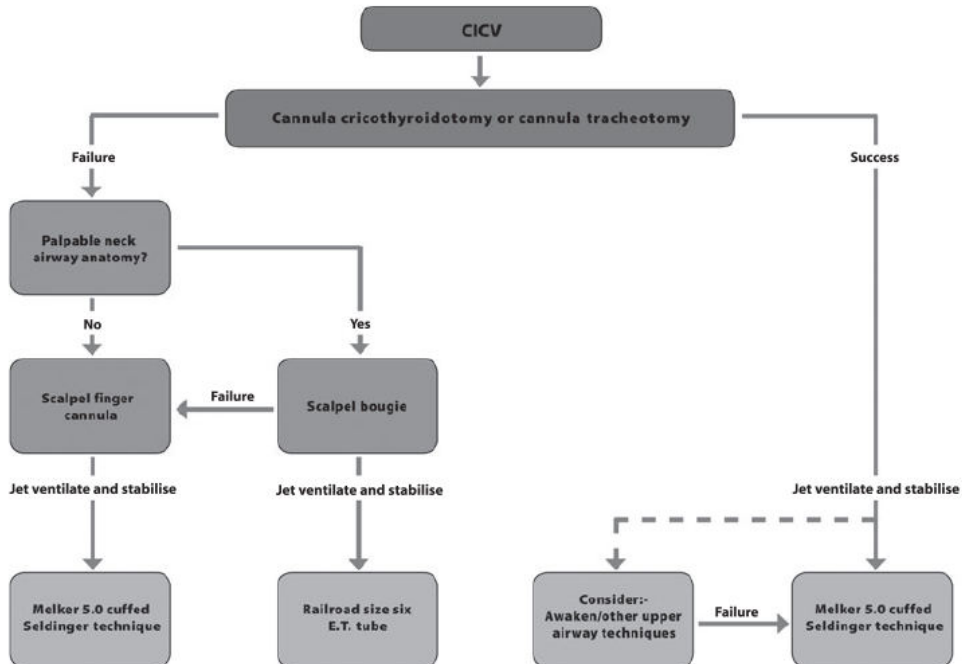

Diagram from A heard et al. *Anaesthesia* 2009; 64: 601-8.

Surgical Airway Equipment: Each theatre in Toowoomba has the following equipment velcroed to a whiteboard behind the anaesthetic workstation to enable performance of all the techniques described in the above algorithm.

- 14 gauge IV cannula: for needle cricothyrotomy, this also requires a syringe with saline.
- COOK cuffed emergency cricothyrotomy catheter set: this contains a 5.0 mm ID tube with introducer, a guidewire and scalpel and two 18g needles- 50 and 70mm long.
- Rapid O₂ flow set: this is a piece of oxygen tubing with a yellow junction that when occluded allows 'jet' insufflation of oxygen down the IV cannula.
- Frova Airway Intubating Catheter + Rapi-fit Adapter: this is a hollow blue plastic tube 65cm long. It is 5mm wide and the adapter allows connection to a standard circuit. It can also be used as a bougie as described above.
- Size 6.0 cuffed ETT + size 10 scalpel: tools to perform a 'scalpel- bougie' or scalpel cricothyrotomy as per ATLS teaching. This is the surgical airway favoured by the DAS.

Some thoughts about awake fibreoptic intubation (AFOI)

- Like any complex technical skill that requires a degree of manual dexterity, awake fibreoptic intubation requires ongoing practice to acquire and maintain proficiency in its performance. It is not like learning to ride a bike. You will not just 'pick it up' again when you need to do it.
- The ANZCA Curriculum identifies it as a core skill and has nominated a minimum VOP of five AFOI's. Most would agree this is an inadequate number to even acquire the skill to any degree of competency.

- The best way to learn is to do the real thing.
- Planning is crucial to the timely successful performance of this skill- patients needing AFOI should be identified well ahead of time and your anaesthetic assistant and supervisor if appropriate notified.
- *Bronchoscopes are expensive and must be handled with care.*

Practical tips

- You need consent from the patient- explain what you will do.
- Secure IV access and apply standard monitoring.
- It is best performed in OT, you can topicalize the patient in the bay.
- Give glycopyrrolate 0.2mg IV- secretions are your enemy.
- Topicalize meticulously: there is a multitude of techniques described. If you can suction the hypopharynx without them complaining you're looking good.
- Sedation is usually warranted- *small* doses incrementally. This is the one time when you want to be giving *conscious sedation*. Remifentanyl is very popular but go gently with this too as it is easy to render the patient apnoeic. Opioids don't provide amnesia either which is generally desirable. If you are really patient you can use dexmedetomidine.
- Give the patient supplemental oxygen- Hudson mask pulled down over the mouth or nasal insufflation using the fine green 6F tubing.
- The nasal route is the easiest to navigate as it is a straighter approach but the nasopharynx needs to be numb and not obstructed. If an 8mm NPA passes easily you should be okay. Ask the patient which nostril they breathe best through.
- I recommend having the patient sitting up and facing you.
- Preload the tube over the bronchoscope- suggest use an armoured or Parker tube. The former is less compressible and the latter is easier to railroad over the bronchoscope.
- Video monitor on, facing you, suction connected and on.
- Always aim for the black. If get 'pinkout'- stop, withdraw and re-orientate.
- Once you visualize the glottis, squirt some lignocaine down, wait for them to stop coughing and then advance the tube.
- To facilitate railroading the ETT- have a snug fit between tube and bronch (6.0 adult), lubrication, rotate 90° anticlockwise, jaw thrust, deep breaths by patient, poke tongue out, *don't force it*.
- Don't induce anaesthesia until you have confirmed intra-tracheal placement of the tube- the only way to do this is by:
 - ETCO₂ and/or
 - Visualization of tracheobronchial rings/ carina with the bronchoscope through the ETT.
- I recommend performing a direct laryngoscopy once the tube has been secured and the patient is anaesthetized and to document the view on AARK. If they are an easy tube then it's probably not warranted to do it again in the future!

SELECTED REFERENCES

The formulation and introduction of a 'can't intubate, can't ventilate' algorithm into clinical practice. A Heard et al. *Anaesthesia* 2009; 64: 601-8. *Well worth reading the entire article, not just the algorithm.*

Difficult Airway Society 2015 guidelines for management of unanticipated difficult intubation in adults. C Frerk et al. *British Journal of Anaesthesia* 2015; 115(6): 827-48. *These are regularly revised and much better than the American equivalent.*

Critical Hemoglobin Desaturation Will Occur before Return to an Unparalyzed State following 1mg/kg Intravenous Succinylcholine. J Benumof et al. *Anesthesiology* 1997; 87: 979-82. *The title says it all.*

Editorial- The obstructed airway in head and neck surgery. R Mason and C Fielder. *Anaesthesia* 1999; 54: 625-8. *A classic editorial and essential reading for all anaesthetists. This oft cited article is succinct and heavily cautions against the panacea of fiberoptic intubation for these cases.*

The Vortex Approach. Management of the unanticipated difficult airway. N Chrimes and P Fritz. 2013. *Available as a free ebook, there is also a website, vortexapproach.com.*

LIGHT RELIEF

THE REAL WORLD CICO ALGORITHM



AT NO STAGE DOES SUGAMMADEX HELP IN THIS SCENARIO

Hypoxia

“Oxygen lack not only stops the machine, it wrecks the machinery.”

JS Haldane

In the majority of crises the problem is obvious as is the solution. The anticipated difficulties facilitating that solution may prompt you to push the big red button on the wall. Most problems are solved intuitively- common things are common. We recognize patterns and we are the products of our personal experience. Anaesthetists are profoundly influenced by personal highly stressful crisis situations. We don't want to revisit them. The use of drills or algorithms is rarely actually required. Their role is for the rarer situation where intuition and the best educated guess and usual interventions haven't worked. They serve as a cognitive aid because generally speaking we need to fix the problem and we don't have all day to do it. For the big three crises which I will discuss it is essential that the anaesthetist can diagnose and treat them. That is why it is worth investing in understanding and applying these cognitive aids.

We all know that the sigmoid shape of the oxygen dissociation curve means that when the sats dip below the nineties, you are starting on the slippery and steep slope towards profound hypoxaemia. The anaesthetist's ears are attuned to the reassuring tone of an oximeter signal in the high nineties. We do not accept poor oxygen saturations lightly. Before we embark on honing our response to desaturation in theatre, the hypoxia drill, it is useful to revisit the causes of hypoxia. For there to be an adequate supply of oxygen to the tissues, all of the following factors must be satisfied:

- Sufficient oxygen in the inhaled gas mixture,
- Proper exchange of gases in the lung,
- A sufficient amount of haemoglobin capable of carrying oxygen,
- Proper function of the cardiovascular system to deliver it to the tissues,
- Which must be able to use the oxygen in their mitochondria.

This leads on to a classification of causes of hypoxia:

- Decreased F_{iO_2} , also called hypoxic hypoxia
- Hypoventilation
- Ventilation Perfusion (V/Q) mismatch
- Diffusion block
- Decreased perfusion of tissues, also called ischaemic hypoxia
- Decreased oxygen carrying capacity of the blood, also called anaemic hypoxia
- Impaired ability of the tissues to utilize oxygen, also called cytotoxic hypoxia and cyanide poisoning is the classic example

Presentation

- $SpO_2 < 90\%$ and the accompanying dire tone of the oximeter
- Cyanosis- this can be hard to pick clinically especially if the surgeon has injected them with patent blue.
- Confusion and restlessness

- Bradycardia in children

Immediate Management= HYPOXIA DRILL

- Believe your monitors. The pulse oximeter is a lag monitor- you are already behind.
- Look at the patient- what is their colour? Are they breathing/ being ventilated? Is their airway patent? Check the pulse oximeter is properly attached.
- Feel the pulse- is this an arrest? Hit the NIBP button to do a reading. Do they have an adequate cardiac output?
- Give high F_iO₂ at a high flow rate and hand ventilate- look for chest expansion. Assess the compliance of the patient's lungs and of the anaesthetic circuit. If you are having difficulty ventilating, disconnect the circuit from the tube and squeeze the bag to quickly exclude a circuit problem.
- Look at your monitors- check the O₂ analyzer to confirm that you are delivering oxygen, look at the capnograph to confirm that you are ventilating the patient.
- Inspect and auscultate the chest- are there wheezes or crepitations? Bilateral air entry? Check the airway device again- if in doubt, remove and replace it.

The above drill will alert you to >95% of causes of hypoxia and lead you towards correcting them. The commonest causes seen intraoperatively are:

- Airway problems- the LMA is malpositioned or leaking, the ETT is obstructed with mucus.
- Hypoventilation- CNS depressants all depress ventilation and these are our mainstay.
- V/Q mismatch- this is less readily corrected but if suspected a trial of alveolar recruitment should be performed. How to do this is described in detail in *Maintenance of Anaesthesia*. Recruitment manoeuvres should correct hypoxia at least transiently- if they don't and you have eliminated the other causes it suggests the presence of a large shunt.

You should appreciate that if a patient is being ventilated adequately with oxygen through a patent airway they should have great sats, even if they smoke or have COPD or are incredibly fat. *There must be something going on if they don't.*

COVER algorithm

The COVER algorithm is included for completeness. Most practitioners don't use it. It is a generic algorithm developed by a group of Australasian anaesthetists in the nineties and can be applied to any intraoperative crisis but is probably most suited to hypoxia and hypotension. The full algorithm is called COVER ABCD A SWIFT CHECK and it is entirely unreasonable to expect anyone to remember what all the letters stand for.

The COVER component refers to:

- C** Circulation
 - Colour
- O** Oxygen
 - O₂ analyser
- V** Ventilate by hand
 - Vaporizer
- E** ETT/ LMA
 - Eliminate anaesthetic machine

R Review monitors
Review equipment

Subsequent Management

- Dictated by cause of hypoxia
- In situations of prolonged hypoxia it is usually appropriate to:
 - Call for help
 - Intubate and ventilate if you haven't already done so
 - Order a CXR and perform ABGs
 - Exclude methaemoglobinemia- ABG for co-oximetry analysis.

Differential Diagnosis

- In the OT I find it is most useful to think of causes of hypoxia in a stepwise manner following the path of oxygen from the pipeline to the alveolus. A nice diagram below reinforces this approach:
 - Wall to airway- wrong gas, O₂ pipeline supply failure, O₂ not turned on (people still forget to do this), circuit has leak/ is disconnected/ is blocked, forgot to turn ventilator on (yes, this too).
 - Airway- LMA/ ETT malposition/ blockage, laryngospasm.
 - Chest: from the trachea to the alveolus and back out to the chest wall-
 - Large airway compression/ trauma
 - Lung vasculature- embolism, shunt, anaemia
 - Alveoli- collapse, oedema, sepsis
 - Diaphragm and chest wall- restrictive deficit
 - CNS- hypoventilation from drugs/ pain/ hypothermia.
- Carbon Monoxide and Cyanide poisoning are rare but potent causes of hypoxia- they are unique in that pulse oximetry readings may be normal or even elevated. ABG will demonstrate severe acidosis.
- An aside- nail polish does not affect the performance of pulse oximeters. This may disappoint many nurses who delight in scrubbing it off in the misguided belief they are doing the patient and yourself a favour.

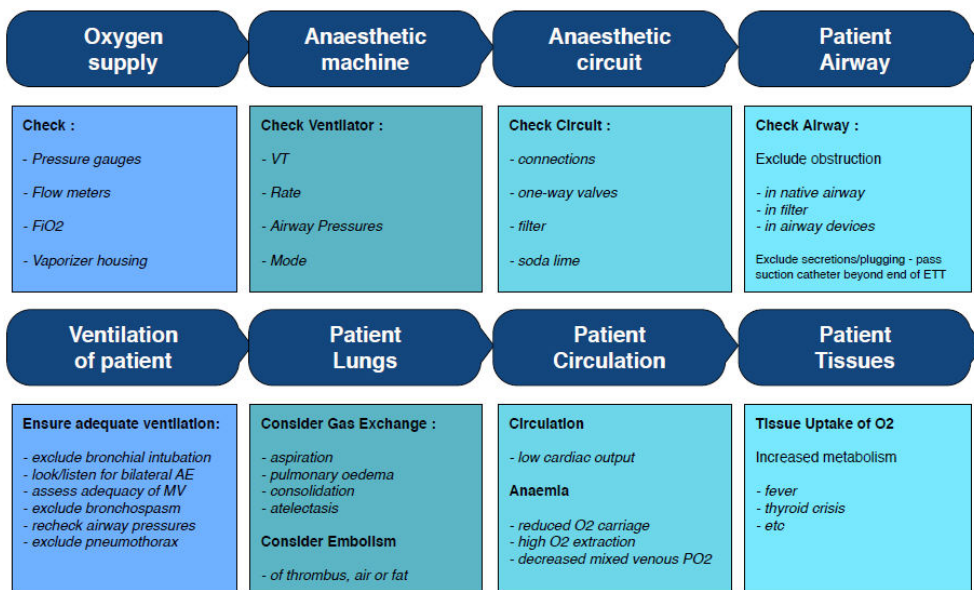

Diagram from 'Rural Hospital Theatre Checklists', a resource compiled by Dr T Leeuwenburg. Accessed from his website kidocs.org

Hypotension

Three digits good, two digits bad if anaesthetist; other way around if surgeon

I have a tutorial about this topic and it starts like this: you are anaesthetizing a 76 year old woman with a history of hypertension for a laparoscopic cholecystectomy. You preoxygenate her, take baseline readings including her BP which is 166/78 and induce her carefully with propofol, fentanyl and rocuronium. After you have intubated her successfully and flipped her onto the ventilator the first NIBP is 76/42. How do you manage this? Is it just anaesthetic overdose? This is not a trick scenario, this sort of thing happens all the time. We need to build a framework to tackle this scenario sensibly.

Presentation

- Low measured BP
- NIBP unable to perform measurement- if the BP has cycled a couple of times without producing a number you have to assume the BP is low because it invariably is. You can always palpate for loss of the pulse as it cycles to determine what the systolic pressure is.
- Poor peripheral perfusion- decreased signal or loss of SPO₂ trace
- Often tachycardia- but severe bradycardia is a cause
- Nausea/ vomiting post spinal anaesthetic
- Confusion, stupor in awake patient

Immediate Management

- ABC- ensure adequate oxygenation and ventilation
- Check BP again (if arterial line, check line and pressure bag, flush it if it looks damped)
- Look at patient's colour and feel pulse (nature, rate, rhythm)
- Scan monitors- ECG, SPO₂, capnogram
- Administer vasopressor- Metaraminol 0.5mg or Phenylephrine 100mcg (caution if bradycardic), Ephedrine 9mg.
- If severe hypotension and not responding to vasopressor: inform surgeon, raise patients legs if able, give Adrenaline iv in 50-100mcg increments
- Optimize preload- 10ml/kg bolus crystalloid. This won't help in the short term.
- Consider decreasing anaesthetic depth- turning the vaporizer down is not going to help you in the short term, however, and you need to remember to deliver adequate anaesthesia once the situation has been stabilized.

Subsequent Management

- Use HPV mnemonic to diagnose cause- see below
- Have a low threshold to place an arterial line- it gives you a continuous, accurate measurement of BP and facilitates blood sampling and one less thing to do when you end up sending this patient to ICU.
- Assess blood loss, consider Hemocue or FBE.

- Treat tachyarrhythmias with synchronized DC cardioversion
- Treat myocardial ischaemia as appropriate- care with GTN if hypotensive.
- Persistent hypotension- intensify the degree of monitoring: arterial line, central line (for administration vasoactive drugs, not to assess the CVP), urinary catheter. Consider vasopressor (peripheral line) or inotrope infusion (central line). Noradrenaline is the agent of first choice if vasodilatation is thought to be the problem.
- Echocardiography is of undoubted great value in the scenario of persistent hypotension as a diagnostic tool and as well as guiding management and assessing the response to your interventions. An echo will tell you if the patient is under filled and whether their left ventricle is working or not. If there is a big clot in the heart or pulmonary artery it will tell you this as well. Having the ability to stick a transthoracic probe on the patient to determine these parameters is a skill every anaesthetist should possess. The current terminology for this is FATE: focus assessed transthoracic echocardiogram.

HPV Mnemonic

There are a host of acronyms and algorithms intended to assist the anaesthetist to remember the huge differential for causes of hypotension. I will limit myself to two which I think are helpful: the HPV mnemonic is a nice one to help remember some of the less common but important causes of hypotension. The PEAS acronym is handy because it also prompts you to assess all the important factors that could be causing hypotension appropriately.

- **H**ypovolaemia
- **H**ear- rate/ rhythm/ contractility
- **P**neumothorax/ **P**ericardial tamponade
- **P**ulmonary Embolism- air/ gas/ fat/ thrombus/ cement/ amniotic fluid
- **V**asodilation- *DASE* acronym: Drugs, Anaphylaxis, Sympathectomy/ Steroid lack, Endotoxin
- **V**asovagal

PEAS Acronym

Patient factors- Is there something wrong with their heart? Look at the patient and your monitors. Think of the factors required for appropriate cardiac function: preload, afterload, contractility, heart rate and rhythm.

Surgical factors- Look over the drapes and determine what the surgeon is doing? Is there bleeding? What is the blood loss? It may be occult.

Anaesthetic factors- What drugs have I given? Is this anaphylaxis?

Equipment- Is the measurement correct? Is someone leaning on the BP cuff? Perform a manual reading, stick that arterial line in.

The big 3: anaesthetic overdose, anaphylaxis and hypovolaemia

Undoubtedly the commonest cause of hypotension post induction is giving too much white stuff too quickly and you are seeing the result of vasodilatation. The cause is obvious as is the management which is to tighten them up with a vasopressor. The great thing about metaraminol is that it always works; the blood pressure always goes in the desired direction. It

needs to be a significant bradycardia for me not to give this as the first line vasopressor. There is no point in giving 3mg of ephedrine, give 9mg or something else. You need to be proactive and keep chasing that BP until you have reached your target. Your therapeutic target is individualized but ideally you want their blood pressure the same as how it started minus about twenty percent. Having a systolic in triple figures is always desirable. It is perfectly reasonable just to watch a healthy patient with a BP of eighty after you have 'slam dunked' them and wait for surgical stimulation, the steel inotrope, to do its job. The same approach for the elderly patient with cerebrovascular disease is totally inappropriate.

If you have used half a syringe of vasopressor and are still struggling to get a decent perfusion pressure then you should be thinking of anaphylaxis. The commonest presentation of anaphylaxis is cardiovascular collapse and a poor response to vasopressor therapy is one manifestation of this. Usually it is more dramatic. Anaphylaxis is the commonest cause of severe hypotension in the final examination viva scenario! If you are still not winning give them adrenaline. Never give this drug neat intravenously.

If you are into the maintenance phase of anaesthesia and hypotension is raising its ugly head then you must consider hypovolaemia. Blood loss is notoriously difficult to assess and is most commonly underestimated. You can lose a lot of blood into your abdomen, pelvis or thigh and not see it. If the drapes are soaked, the sucker bottle is full or the nurses are counting the next set of packs then there is significant blood loss happening. It is so quick and easy to do a hemocue. If you have collected the specimen correctly a hemocue is as accurate as a formal FBE. You should believe it. Think twice before transfusing, though. See *The bleeding patient and transfusion therapy*.

4 causes of acute hypotension and hypoxia

This is a good list to keep in mind:

1. Pneumothorax- laparoscopy, chest trauma
2. Pulmonary Embolism- cement, large bone fracture, obstetrics
3. Acute left ventricular failure- ischaemia is the commonest precipitant
4. Aspiration- not good.

High Airway Pressure

All that wheezes is not asthma

Just as there is a 'hypoxia drill' there is also a 'high airway pressure drill'. They are both very similar as both conditions often coexist. It is important to appreciate what normal airway pressures are produced with IPPV through an endotracheal tube. Most machines have a default alarm setting of 40cm H₂O which is pretty high. Normal peak pressure should be around the twenty mark so if the machine is alarming you can safely assume that something is definitely wrong. This section will also briefly address two crises that present with high airway pressures, namely bronchospasm and the 'can intubate but can't ventilate' scenario.

Presentation

- High airway pressure alarm
- Low tidal volume/ minute volume alarm if IPPV
- Difficult manual ventilation, 'tight' bag
- Abnormal or even absent capnograph trace
- Hypotension due to raised intrathoracic pressure impeding venous return

Immediate Management= HIGH AIRWAY PRESSURE DRILL

- Switch to manual ventilation using high FIO₂ and high flows.
- Squeeze bag to confirm difficult ventilation.
- Scan breathing system and airway device for obvious obstructions, eg. kinked tube/ tubing.
- If signs of light anaesthesia (laryngospasm/ coughing/ biting on tube) deepen anaesthesia with IV propofol.
- Check muscle relaxation using nerve stimulator.
- Check circuit is okay* by disconnecting from airway device and:
 - Confirming reservoir bag empties easily while disconnected *and*
 - When attach 2nd bag to end of circuit you can easily fill each bag in turn by squeezing them alternately. (This assesses the integrity of the inspiratory and expiratory valves.)
 - If the bag doesn't empty easily or the 2nd bag is abnormally distended, abandon the circuit and use an alternative means of ventilation, i.e. AIR VIVA bag attached to the machine.
- If ventilation is still difficult the problem is with the airway device or the patient.
 - Check the ETT/ LMA is positioned correctly and patent:
 - Remove/ reposition/ replace as necessary.
 - Consider passing a suction catheter down the ETT to assess patency.
 - Examine the patient:
 - Auscultate chest for: wheezes/ crepitations (?bronchospasm), bilateral air entry (?endobronchial intubation).
 - Inspect chest for movement/ feel tracheal position/ look for distended neck veins (? pneumothorax)

- Look for rash (?anaphylaxis)

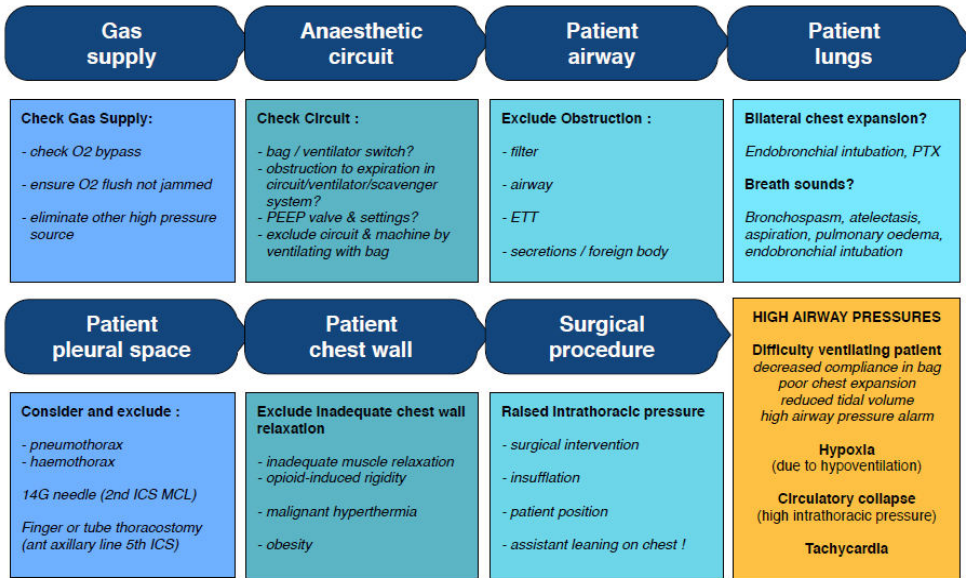

Diagram from 'Rural Hospital Theatre Checklists', a resource compiled by Dr T Leeuwenburg. Accessed from his website kidocs.org

Special Considerations

- There is a large list of possible patient related causes of high airway pressures but commoner causes are:
 - Return of muscle power
 - Bronchospasm (see below)
 - Lung/ lobar collapse
 - Aspiration
 - Pneumothorax
 - Pulmonary oedema
- In some situations the raised airway pressure may be appropriate for the clinical scenario, eg. Obese patient in the Trendelenburg position with a pneumoperitoneum. Nevertheless common causes of high airway pressure need to be searched for and excluded before accepting elevated airway pressures. A common example is migration of the ETT down the right main bronchus in an obese patient undergoing a laparoscopic procedure.
- Ventilator strategies to limit airway pressure in clinically appropriate scenarios include:
 - Decrease tidal volume and respiratory rate
 - Increase I:E ratio to 1:1
 - Turn off PEEP
 - Avoid steep Trendelenburg
 - Use Pressure Controlled Ventilation (PCV) but check minute volume ventilation is adequate; may have to accept a degree of hypercapnia.

- If using PCV- lower expired tidal volumes may be the first and only indication of a problem. ET CO₂ takes some time to rise.
- *The circuit is almost never the problem- it has been checked before you started after all. Disconnect from the most distal connection which is the tube itself. The HME filter is a possible culprit as this is changed after each case. Increased expiratory resistance in the breathing system can be very difficult to diagnose unless you test the circuit with a 2nd bag attached.
 - Causes include a malfunctioning APL valve, expiratory valve sticking or stuck closed, ventilator expiratory valve stuck, scavenging system malfunction
 - It may be a diagnosis of exclusion when there is difficult manual ventilation despite excluding airway and patient problems.
 - Management entails disconnecting the patient from the circuit to release the high intrathoracic pressure (the so called 'Lazarus' effect) and using an alternative ventilation system.

Bronchospasm

This is usually pretty simple to diagnose. Your smoking asthmatic patient has been intubated and now the bag feels tight and the wheezing is loud enough for you to hear it without a stethoscope. The books claim that anaphylaxis presents with bronchospasm in fifteen percent of cases. Most bronchospasm makes itself evident on induction as it is the airway instrumentation that is causing the problem. Be aware that an endobronchial intubation will present in a very similar way so make sure your tube placement is optimal.

Severe bronchospasm can be bad enough that you get no capnograph trace at all and the bag doesn't feel all that tight because there is no gas coming back to fill it. If you have no capnogram you must assume the tube is not in the trachea and you should remove it and replace it as your first manoeuvre. The exception is where you have a clear view of the glottis and directly visualized the tube going through the cords. Most bronchospasm is not this severe and is managed with the following:

- Optimizing tube position
- Deepening anaesthesia
- Administering a bronchodilator- the best and most readily available bronchodilator is your volatile agent. Sevoflurane should be used in preference to desflurane. Rarely are beta 2 agonists necessary and they should be administered via aerosol down the tube initially. Second line and alternative bronchodilators are even more rarely required.

Commonly you will need to manually ventilate the patient until they have responded to treatment. The ventilator won't cope with the pressures and this also enables you to assess the response to treatment. Check their blood pressure is alright as the raised intra-thoracic pressure markedly reduces preload. The spasm will resolve when you remove the plastic from their throat and you should counsel them firmly not to smoke. I would reverse them with sugammadex instead of neostigmine as anticholinesterases can exacerbate bronchospasm (that's presuming you didn't use cisatracurium).

Can intubate, can't ventilate

This is one of the most distressing crises you will ever have to manage. There are four areas where the problem may be:

- The anaesthetic machine and breathing circuit- as discussed above this is *very rarely* the problem. If it is use an alternative means to inflate the lungs, i.e. self inflating bag.
- The tube- it can be blocked, kinked, down too far, the cuff is herniated or not in the trachea. If in doubt remove it and reintubate.
- Lungs distal to the ETT- obstruction or compression of the trachea or bronchi. Severe bronchospasm will do this as will mucus plugs. If bronchial compression is suspected then changing the patient position may help- turn them into the lateral position or even prone. You may be able to push the tube past the obstruction. A MLT tube is the longest single lumen tube that is available. A rigid bronchoscope may also be helpful in this situation but requires an ENT surgeon to wield it.
- Chest wall- muscle rigidity may be the problem from a non paralysed patient fighting you or a bolus of remifentanyl. The other important cause is a pneumothorax. Needle decompress the pneumothorax and get the surgeon to put the chest drain in.

Perioperative Medicine

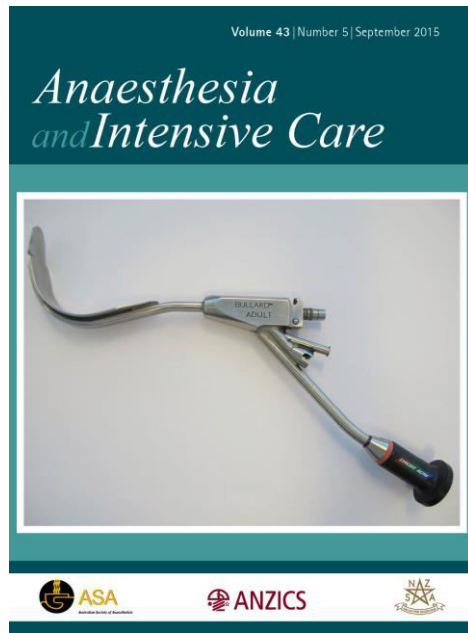
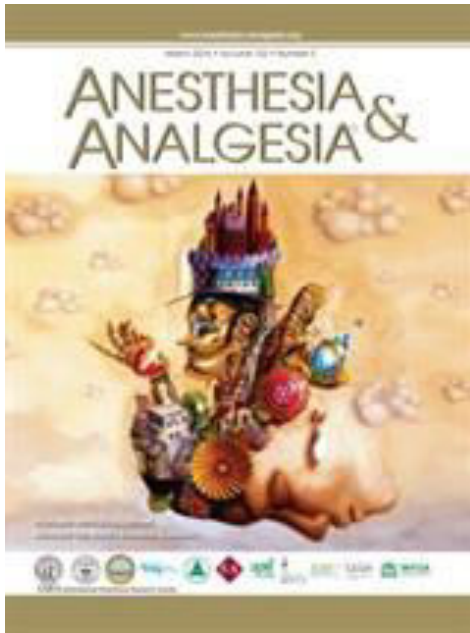

Volume 116, Number 3, March 2016 ISSN 0007-0912 (Print) 1471-6771 (Online)

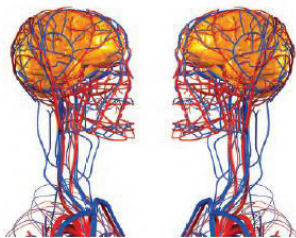

In this month's issue
• CVC placement • Airway management

OXFORD
UNIVERSITY PRESS

OXFORD OPEN



Changes in the Anesthesiology Physician Workforce:
A Report from the RAND Corporation

Studies you should probably know about

Most people just read the abstract

If you are interested in the history of anaesthesia and reading about landmark studies that have been performed then there are two books I highly recommend. The first is an American book that is now out of print but second hand copies are still available on Amazon. It is called *Classical Anaesthesia Files* and was written by David M Little. The book is a compilation of a series of articles that were originally published in the American journal, *Survey of Anesthesiology*. The articles comprised a series of classic papers each with an accompanying introduction written by the erudite Dr Little and span a little over a hundred years from the advent of modern anaesthesia. The introductions are the prime attraction and the book only includes the opening page of the original articles. There are some amazing papers discussed here and to whet your appetite here are some of the ones that particularly intrigued me: ‘The lack of cerebral effects of d-tubocurarine’; ‘Spinal Anesthesia. With special reference to its use in surgery of the head, neck and thorax.’; ‘Continuous spinal anesthesia: a new method utilizing a ureteral catheter’ and ‘The unreliability of cyanosis in the recognition of arterial anoxemia’. The other book is somewhat unimaginatively called *Landmark Papers in Anaesthesia* and is a British book first published by the Oxford Press in 2013. The editors are Nigel Webster and Helen Galley and this book deals with more contemporary papers.

Unfortunately, in terms of potential entertainment value, this section is not about these two books. I will attempt to distil papers that have been written in the last decade or so that are of significance and the practising anaesthetist should be familiar with the implications of their findings. Quite a few important papers have already been discussed. The B-Aware, B-Unaware and BAG-RECALL studies were discussed in the chapter on the EEG and its application to anaesthesia. CRASH-2, the largest trauma trial ever and the important ‘transfusion’ trials are discussed in the following chapter about *The Bleeding Patient*.

The Australasian anaesthetic community should be proud of its contribution to high quality anaesthetic research about topics of importance to practising anaesthetists. The ANZCA Clinical Trials group leads the way in this respect and has also made important contributions to major collaborative studies like the POISE trials. Of the thousands of papers published each year in assorted anaesthetic journals there is maybe one or two that are truly important. Of these, even fewer will lead to a change in practice, as many are ‘negative’ studies. By this I mean the intervention did not lead to an improved outcome. Before we get to the specifics of some important trials I have listed below the names of some anaesthetists who consistently publish studies and editorials of the highest quality. I have grouped them by country of practice:

Australia and New Zealand

Paul Myles, Kate Leslie, David Story, Matthew Chan, Andrew Davison

Great Britain

Steve Yentis, David Bogood, Andrew Lumb.

United States

Dan Sessler, Steve Shafer, Scott Beattie, Bruce Spiess and Richard Dutton.

I should also mention that anaesthesia has been notorious of late in terms of research fraud and the following doctors can be safely termed criminals: Scott Reubens, Dan Poldermans, Joachim Boldt and Yoshitaka Fujii. The latter is possibly the worst exponent of research fraud of all time. The journal *Anaesthesia* published an astonishing article by John Carlisle on the eight of March 2012 which detailed a statistical analysis of 168 of Fujii's papers to investigate their data integrity. Carlisle reported that the chances of the data sets arising by chance was about one in a hundred and fifty million. A subsequent investigating committee found that only three of Fujii's 212 studies contained valid data.

The Studies (in no particular order)

Perioperative Medicine and Anaesthetic Management

Mangano- this was the first big trial that heralded the ultimately false hope that the perioperative administration of beta blockers would decrease perioperative adverse cardiovascular events and death. Mangano's modestly sized trial reported a significant and large decrease in both outcomes. However if the data was analysed on an intention-to-treat basis there was no mortality benefit. Subsequent studies reported by the Poldermans group, the DECREASE studies, also reported impressive positive results with another beta-blocker, bisoprolol. Unfortunately Poldermans was later found guilty of research fraud.

Effect of atenolol on mortality and cardiovascular morbidity after noncardiac surgery. D Mangano et al, *NEJM* 1996; 335: 1713-20.

Coronary Artery Revascularization Prophylaxis (CARP) Trial. It would seem intuitive that if a patient had coronary artery disease bad enough to warrant revascularization then they would have a better outcome if they were revascularized before they underwent major surgery. This was the premise of the CARP trial in which 500 patients due to undergo vascular surgery were randomized to revascularization with CABG/ percutaneous coronary intervention or to medical therapy. It was a negative study in that the rates of mortality and postoperative MI were not significantly different. The conclusion was that revascularization is not warranted if the only intention is to decrease the risk of subsequent surgery.

Coronary-artery revascularization before elective major vascular surgery. E McFalls et al. *NEJM* 2004; 351: 2795-804.

POISE (PeriOperative ISchemic Evaluation) 1 and 2- these are the largest perioperative medicine trials ever conducted. POISE 1 was also marred by research fraud and led to almost a thousand subjects being excluded from the study. Over eight thousand patients undergoing non-cardiac surgery were randomized for the perioperative administration of metoprolol or placebo. Although the incidence of postoperative cardiac events including myocardial infarction was reduced, mortality was increased mostly as a result of a doubled incidence of stroke. This was effectively the death knell of perioperative beta-blockade although I should stress that patients already on a beta-blocker should continue to take them in the perioperative period. Undeterred, the POISE researchers conducted the even bigger POISE 2 trial which was a crossover trial involving over ten thousand patients that evaluated two interventions- the perioperative administration of clonidine and aspirin versus placebo. The findings were reported in two separate papers. Clonidine and aspirin both failed to achieve a benefit in terms

of mortality or cardiac events. Aspirin therapy was implicated in an increased incidence of significant bleeding and clonidine caused an increased rate of clinically important hypotension. If aspirin was withheld there was no increased incidence of thrombotic events.

POISE 3 will look at rosuvastatin and tranexamic acid.

Effects of extended-release metoprolol succinate in patients undergoing non-cardiac surgery (POISE trial): a randomised controlled trial. P Devereaux et al. *Lancet* 2008; 371: 1839-47.

Aspirin in patients undergoing noncardiac surgery. P Devereaux et al. *NEJM* 2014; 370: 1494-1503.

Clonidine in patients undergoing noncardiac surgery. P Devereaux et al. *NEJM* 2014; 370: 1504-13.

ENIGMA (Evaluation of nitrous oxide in the gas mixture for anaesthesia) 1 and 2- these were two large multicentre randomized trials which evaluated the use of nitrous oxide as a component of general anaesthesia for major surgery. The first trial found a benefit with the omission of nitrous in that there were fewer major complications and less PONV. There was no difference in mortality or cardiac events. However the validity of the conclusion was questioned because the oxygen concentration was not controlled, i.e. it was increased in the nitrous free group. The trend for increased cardiac events in the nitrous group also helped encourage the investigators to perform the larger ENIGMA 2 trial which controlled for FIO₂. This trial found little difference between the two groups probably to the great disappointment of the investigators. PONV was again increased in the nitrous oxide group.

Avoidance of nitrous oxide for patients undergoing major surgery. A randomized controlled trial. P Myles et al. *Anesthesiology* 2007; 107: 221-31.

The safety of addition of nitrous oxide to general anaesthesia in at-risk patients having major non-cardiac surgery (ENIGMA-II): a randomised, single blind trial. P Myles et al. *Lancet* 2014; 384: 1446-54.

MASTER- Multicentre Australian Study of Epidural Anaesthesia. This trial enrolled 915 high risk patients undergoing major surgery and randomized them to a combined GA/ epidural versus a GA with systemic opioids. Most of the epidurals were thoracic epidurals but only about half of them completed the intended duration of the protocol. It was a 'real world' study in this respect. There was no mortality benefit, a very modest improved analgesia effect in the epidural group as well as a decreased incidence of pulmonary complications in a high risk subgroup. This study didn't promote the practice of thoracic epidural anaesthesia in Australasia. Epidural anaesthesia and analgesia and outcome of major surgery: a randomised trial. J Rigg et al. *Lancet* 2002; 359: 1276-82.

PROXI- after ENIGMA, this was the largest trial that looked specifically at whether there was a benefit to using an oxygen enriched gas mixture intraoperatively for major bowel surgery. Previous trials had reported a significant reduction in SSIs with oxygen supplementation. PROXI, which enrolled 1400 patients, negated these and found no difference in any of the studied outcomes including SSI.

Effect of high perioperative oxygen fraction on surgical site infection and pulmonary complications after abdominal surgery. The PROXI randomized clinical trial. C Meyhoff et al. *JAMA* 2009; 302: 1543-50.

Fluids

There are no significant perioperative trials comparing IV fluids despite these being possibly the most commonly prescribed drugs by anaesthetists. All studies are small, sub specialized and do little to inform our clinical practice.

The only significant trials worth mentioning have been done in Australasia. Both are ICU based and compare fluids for resuscitation only. The SAFE trial compared saline and albumin and the CHEST trial compared saline and hetastarch (voluven). Neither found a mortality difference.

SAFE- This large RCT compared 4% albumin with normal saline for intravascular fluid resuscitation in 7000 patients admitted to 16 tertiary hospital ICUs. There was no difference in outcome in terms of morbidity or mortality. On subgroup analysis there was a trend towards increased mortality in neurotrauma patients with the use of albumin whereas there was a trend towards increased mortality in severe sepsis patients with the use of saline.

A comparison of saline and albumin for fluid resuscitation in the intensive care unit. The SAFE investigators. *NEJM* 2004; 350: 2247-56.

CHEST- was similarly powered and conducted. They reported a higher need for renal replacement therapy in the starch group- the confidence interval was 1-1.45. There were more adverse effects in the voluven group, mostly relating to itch. On this basis voluven has been effectively banned from use in Australasian ICUs. The few, small perioperative trials with voluven showed improved outcomes (including less renal injury) funnily enough.

Hydroxyethyl starch or saline for fluid resuscitation in intensive care. J Myburgh et al. *NEJM* 2012; 367: 1901-11.

The UK National Audit Projects (NAP)

A total of five of these have been conducted to date. These are all large country wide prospective audits and have provided very useful real world information about clinical practice. They are the largest audits of their type in the world. The focus of the last three has been on adverse outcomes that are of interest to all anaesthetists. The topics investigated are listed below:

1. Supervisory role of consultant anaesthetists
2. Place of mortality and morbidity review meetings
3. Major complications of central neuraxial block in the UK
4. Major complications of airway management in the UK
5. Accidental awareness under general anaesthesia in the UK

NAP 6 will be about perioperative anaphylaxis. The details of all of them can be accessed via the Royal College of Anaesthetists website. NAP3 reported an overall incidence of permanent neurological damage after central neuraxial block of 1 in 24,000 with a higher rate with epidurals than spinals. NAP4 is a fascinating and sobering report that I believe every anaesthetist should read. It predominantly focused on surgical airways and found a high failure rate and high degree of morbidity associated with these especially when conducted in locations other than the operating theatre. It highlighted that the training and ability of anaesthetists to deal with complex airways was inadequate in many respects. I'm sure that experience is not unique to the United Kingdom. The major findings of NAP5 were that the overall incidence of awareness was very low, about 1 in 19,000 anaesthetics. The incidence was higher when muscle relaxants were used and GA caesarean section remained a high risk group for awareness.

GALA- To my knowledge this is the only clinical trial of significant size that randomizes patients to two different modes of anaesthesia. Carotid surgery was an excellent choice because if there was going to be a difference detected you'd have thought this was the prime candidate operation to demonstrate it. Over 3500 patients participated in the trial and disappointingly (or not) there was no difference in any of the primary outcomes- death, stroke and myocardial infarction.

General anaesthesia versus local anaesthesia for carotid surgery (GALA): a multicentre, randomised controlled trial. GALA trial collaborative group. *Lancet* 2008; 372: 2132-42.

Forthcoming trials

The two trials described are both in progress and are run by ANZCA trials group investigators.

BALANCED will study the influence of depth of anaesthesia on a range of outcomes including one year postoperative mortality. The two groups are randomized to general anaesthetics with different BIS targets, 35 and 50. They want to recruit 6500 patients. As well as being a difficult study protocol to conduct, I suspect this will be a negative study. The large retrospective audits have shown an association between deep planes of anaesthesia and increased mortality in the long term.

RELIEF (Restrictive versus liberal fluid therapy in major abdominal surgery) will compare two fluid regimens in major surgery in almost 3000 patients. The liberal regimen is about 6 litres in the first day versus two litres a day in the restrictive limb. This seems a strange regimen as current clinical practice predominantly favours restrictive fluid therapy. This trial is unlikely to change practice.

A cynic may dismiss all the above studies with the adage: "It's not what you do; it's how you do it." I say this all the time because I believe it is true. However, randomized controlled trials aren't designed to demonstrate the prowess of the individual anaesthetist. As a specialty we have mostly failed in identifying specific interventions that when instituted by practitioners as a whole lead to improved outcomes. More thoughts on this topic are espoused in *Making a Difference*.

Antithrombotic Drug Management

This is a dry topic but one that anaesthetists need to know back to front. Surgeons perennially ask you how to manage these drugs. They ask you because they don't know which at least demonstrates a degree of insight on their part. Haematologists, general physicians and pharmacists will all give you advice that is often contradictory. None of these people have to stick a needle into someone's back either. There is an astounding degree of ignorance and confusion regarding how to manage these drugs. The cardiologists are continually embracing and prescribing progressively more potent drugs that are increasingly more difficult to antagonize. There are a host of guidelines regarding perioperative management that again suffer from lack of consistency. We are the mugs that have to manage the bleeding or thrombotic episodes that result if management is suboptimal so it is in everyone's best interests that we are up to date with best practice. Undoubtedly the most widely respected and endorsed guidelines regarding the use of antithrombotic drugs in the context of regional anaesthesia are those produced by ASRA. ASRA is the American Society of Regional Anesthesia and Pain Medicine and Terese Horlocker is the lead contributor. Their fourth edition is due to be released shortly. As I have said before in this book- we are the perioperative physician. This knowledge is part of our expertise. You should not need to ask a haematologist.

Preoperative Management- general considerations

- Perioperative management of these drugs is a balance between the risk of thrombotic events and the risk of bleeding. There is poor quality evidence to guide this risk assessment process. An approach using consensus guidelines tailored to the individual patient undergoing a specific procedure is the current standard of care.
- Check (if anaesthetist) and document (if surgeon) on the elective surgery bookings form any orders relating to antithrombotic medications.
- Generally speaking it is not necessary to cease low dose aspirin or NSAID monotherapy in the perioperative period. Consideration may be given to ceasing low dose aspirin three days preoperatively in patients at low risk of thrombosis but high risk of bleeding as per the POISE 2 trial.
- Does the drug have to be stopped? –for surface or minor surgery it may be reasonable to proceed without stopping the drug. *It is recommended to liaise with the consultant/ operating surgeon if you are considering **not** stopping antithrombotic medication.*
- Patients who attend PAC will have a perioperative regimen instigated by the attending anaesthetist. It is strongly recommended that patients on these medications are referred and seen in the anaesthetist Preadmission Clinic.
- Most thrombotic events occur after the procedure when the patient has gone home. Our responsibility as treating physicians extends to ensuring that patients' antithrombotic medications are recommenced prior to discharge and that their treating doctor is aware of the management plan. Bridging clexane may need to be continued until warfarin is therapeutic for example.
- In my hospital we have instituted a sticker to remind doctors to recommence an antithrombotic that was ceased perioperatively. It is reproduced below.

STK509	WARNING	v2.00/02/2014
Antithrombotic Medication		
This patient has had stopped to facilitate surgery.		
Please ensure recommencement plans for this prior to discharge.		
Date...../...../.....	Name	Sign.....

Preoperative Management of specific drugs if they are to be stopped

Clopidogrel (Iscover, Plavix)- cease this 7 days preoperatively; consider aspirin cover in this period-100mg daily and if on dual antiplatelet therapy patient they should remain on aspirin.

Prasugrel (Effient) –same as clopidogrel

Ticagrelor (Brilinta)- same as clopidogrel

Warfarin- cease 5 days preoperatively (i.e. 4 doses have been withheld) and check INR on the day. Target INR is ≤ 1.4 . ASRA recommends a normal INR prior to neuraxial puncture.

Patients requiring bridging therapy with LMWH are to commence this on day 2. Patients having LMWH are to have the last dose on the day prior to surgery. There are separate guidelines relating to which patients require bridging therapy. The BRIDGE trial’s findings do not recommend bridging therapy for patients on warfarin for atrial fibrillation only.

Generally speaking the following patients require bridging:

- Mechanical heart valve especially mitral valve
- Thromboembolic episode within the last six months
- Severe thrombophilia eg. Antithrombin III deficiency
- CHADS score of 5 or 6- The CHADS criteria are age>75, hypertension, diabetes, congestive cardiac failure and TIA/stroke. Score one for each criterion except the last one which scores two.

The recommended method to acutely reverse warfarin therapy is with Prothrombinex 50 units/kg if INR>3 and 30 units/kg if INR<3. Prothrombinex contains factors II, IX and X. Complete the infusion one hour prior to intended surgery, repeat PT testing is not required. The onset of action is within ten minutes and the duration of action of prothrombinex is about twelve to sixteen hours. I don’t recommend neuraxial blockade in this context. FFP is unnecessary and Vitamin K is slow and unreliable. A large dose of Vitamin K is almost never warranted. Not only does it take ages to work but it takes even longer when you want to anticoagulate the patient again.

SC Unfractionated Heparin- withhold am dose, there is no evidence this is a significant contributor to perioperative bleeding. It is also not a contraindication to neuraxial blockade.

Clexane (LMWH)- last dose 12 hrs prior if the patient has normal renal function and 24hrs if they have renal impairment or been given a therapeutic anticoagulation dose (1.5mg/kg daily or 1mg/kg bd).

IV Heparin infusion- cease four hours prior, check APTT also if renal impairment.

Dabigatran (Pradaxa)- cease five (5) days prior

Rivaroxaban (Xarelto)- cease three (3) days prior

Apixaban (Eliquis)- cease three (3) days prior

The recommendations about the above three drugs entail the most conservative approach. Even if you have a patient with renal impairment booked for a laparotomy that you want to do a thoracic epidural; if you have stopped the above agents for the suggested timeframes then you will be okay to proceed. High risk patients on Dabigatran may need bridging because of the longer timeframe.

Postoperative Management- general considerations

- Most drugs can be recommenced the next day at the dose they were taking prior to cessation. *It is important to recommence these medications prior to discharge.*
- In cases where the patient has had major surgery and/or there are concerns with bleeding or haemostasis it is prudent to withhold antithrombotics and liaise directly with the surgeon responsible. Most guidelines suggest withholding these for at least 48hrs.

Postoperative Management- specific drugs

Warfarin- recommence at normal dose on 1st postoperative day.

For patients on bridging therapy- continue clexane along with restarting warfarin until the INR is therapeutic. This will take several days and require liaison with the primary medical practitioner.

Rivaroxaban – for orthopaedic surgery thromboprophylaxis, the recommendation is for the first dose to be given six hours postoperatively (not if there are concerns with bleeding).

SC heparin- can be given in OT after consultation with surgeon.

IV Heparin infusion- recommence after consultation with surgeon, generally a loading dose is not indicated.

Clexane (LMWH)- can be given six (6) hours after neuraxial puncture. Antithrombotics including clexane should be withheld for at least two hours after removal of an epidural or nerve/ plexus catheter. Patients receiving heparin therapy for several days should have their platelet count checked. HIT syndrome can be fatal.

Notes re the NOACs- new oral anticoagulant drugs

- There is no effective antidote for any of these drugs. (There are reversal drugs in development but they are not here yet and when they do get here they will cost as much as Novoseven*.) The best option is to delay surgery. Even a delay of 24 hours will significantly reduce the likelihood of bleeding as a direct result of drug anticoagulant activity.
- Testing for these drugs is unreliable and specific assays are generally only available in tertiary centres. If you request a standard coagulation screen (PT, APTT, fibrinogen) and it is completely normal then it is *unlikely* that there is significant anticoagulant activity but this is not guaranteed. Dabigatran (thrombin inhibitor) prolongs TT and APTT; Rivaroxaban (factor Xa inhibitor) prolongs PT and APTT to a lesser extent and the response to Apixaban (factor Xa inhibitor) is very variable.
- These drugs should not be used in patients with significant renal or hepatic impairment. They have prolonged half-lives in this instance.

- For patients with normal renal function undergoing 'low risk' surgery it is reasonable to withhold them for only one day.
- In the event of performing emergency surgery on these patients when they have anticoagulant on board:
 - Expect major haemorrhage- Xmatch, ICU, liaise directly with anaesthetist, blood bank, haematologist
 - Dabigatran is removable by haemodialysis
 - The following drugs are suggested:
 - **Prothrombinex 25-50 units/kg**
 - **Tranexamic Acid 15-30mg/kg**
 - **Novoseven (rFVIIa) 50mcg/kg**
 - ***Idarucizumab 5g over 10 minutes** is a monoclonal antibody recently available via the Special Access Scheme that antagonizes Dabigatran rapidly for 24 hours. Good luck getting hold of it.
 - There is no evidence base to guide your therapy.

SELECTED REFERENCES

New Oral Anticoagulants- A practical guide on behalf of the Australasian Society of Thrombosis and Haemostasis. Published in *Internal Medicine Journal* 2014; 44: 525-536.

Qld Health Guidelines- Guideline for managing patients on Dabigatran 5/2016 and Guideline for managing patients on a factor Xa inhibitor 11/2014.

ASRA 3rd revised Guidelines: Regional Anesthesia in the Patient Receiving Antithrombotic or Thrombolytic Therapy 2010.

Prothrombinex-VF product guidelines October 2014.

Review Article. Management of peri-operative anti-thrombotic therapy. *Anaesthesia* 2015; 70(Suppl 1): 58-67.

Perioperative Bridging Anticoagulation in Patients with Atrial Fibrillation. J Douketis et al for the BRIDGE Investigators. *New England Journal of Medicine*, 2015; 373: 823-33.

The bleeding patient and transfusion therapy

The top ten causes of perioperative bleeding are inadequate surgical haemostasis

Anaesthetists and oncologists give the majority of blood products in the hospital setting. The majority of blood transfusions given in hospital are given to stable patients with a Haemoglobin concentration between 7 and 10. This is just causing harm. This section is to help you appreciate this fact. It is important to distinguish between two classes of patient. There is the actively bleeding patient who is clearly compromised and then there is the stable patient who has lost blood but is no longer bleeding. The former group is small but require aggressive resuscitation including the use of blood products. We will consider the management of this group in some detail because the anaesthetist truly plays a pivotal role in saving that person's life. The number one priority in the bleeding patient is to *stop the bleeding*. You need a surgeon for this (or failing that, an obstetrician). Our role is to facilitate optimal conditions for them to stop the bleeding: a warm, normovolaemic, anaesthetized patient that has some clotting factors left to make a clot.

Settings in which massive bleeding can occur

- Major trauma
- Major orthopaedic surgery
- Cardiothoracic, vascular and transplant surgery
- Obstetric emergencies (See *Obstetric Anaesthesia*)
- GI haemorrhage
- Patient on anticoagulants

Preoperative Assessment

- History is the best 'test'- Has the patient had prior surgery, is there a past or family history of a bleeding disorder?
- Drug History- antithrombotics, alcohol and OTC drug use.
- Organ Disease – renal disease, liver disease, autoimmune disease, haematological disorder.
- The commonest inherited bleeding disorder is Von Willebrand's disease (VWD) - there are several types, the commonest is responsive to DDAVP. Routine coags will be normal.
- The haemophilias are rare and warrant haematologist involvement. They will not be discussed further.
- Screening asymptomatic patients with coagulation studies is not of benefit.
- Measures of intrinsic pathway
 - APTT normal 25 – 35 secs
 - ACT normal 90 – 120 secs (rapid, bedside test)
- Measures of extrinsic pathway (factor VII activated by tissue factor)
 - PT normal 10 – 12 secs (tissue thromboplastin added to plasma)
- Fibrinogen concentration and the Thrombin time is a measure of fibrinogen function
- Measures of platelet function

- Bleeding time best, there are numerous 'platelet function tests' and they have nothing to recommend them.
- There is a poor correlation between preoperative studies and actual perioperative bleeding.
- Undoubtedly the most important tests are a group and hold and a FBE for a baseline haemoglobin concentration and platelet count. If you have time anaemia should be treated with iron supplementation, preferably parenterally as well as consideration for erythropoietin therapy.

Assessing bleeding risk and actual blood loss

- This is difficult and tends to be underestimated.
- Factors that determine risk of bleeding apart from the extent or type of surgery include:
 - Ability to control bleeding- eg. TURP can't tamponade venous plexuses
 - Actual and anticipated rate of bleeding, eg ruptured AAA or hole in IVC versus a slow continual ooze
 - Consequences of uncontrolled bleeding: does the patient have any reserve
 - Co-morbidities. Consider the elderly patient:
 - poorly tolerate decreased perfusion pressures
 - Right shift in autoregulation curves
 - Less reserve and ability to compensate
 - Drug treatment (beta blockers) may mask signs of decompensation
 - Concomitant cardiovascular disease.
 - Renal impairment
- Intraoperative [Hb] as measured by hemocue is reliable if you have collected the specimen correctly (preferably from an arterial line).
- Early measurements may underestimate the degree of loss as haemodilution has not yet occurred.
- Sucker bottle volumes/ weighing sponges/ looking at CVS parameters/ amount transfused- all this information should be incorporated into your decision making. Don't forget that anaesthesia alters the CVS parameters used to assess blood loss, especially tachycardia.

The pathophysiology of trauma

- Uncontrolled bleeding is the main cause of death in the trauma patient. Coagulopathy is lethal.
- Trauma itself can cause a coagulopathy separate to the degree of blood loss and this seems to be best reversed by the early use of fibrinogen.
- The triad of hypotension, hypothermia and acidosis is associated with a very high incidence of coagulopathy.
- An aggressive approach is warranted, including the use of blood products to optimise tissue oxygenation and prevent the adverse sequelae of hypovolaemic shock- point where oxygen delivery becomes flow dependent (critical DO₂).

- The current ethos regarding the use of blood products has largely been informed by the military experience in the Middle East. They give whole blood or whole blood equivalent in terms of a 1:1:1 ratio of packed cells to plasma to platelets.
- The problem with using stored blood to improve DO₂ is two-fold: 1) It is depleted in 2,3 DPG so has a high affinity for oxygen (left shift ODC) and so is poor at offloading oxygen in the tissues and 2) it is poor at perfusing the microcirculation as old erythrocytes are swollen, rigid and abnormally shaped.
- There are no reliable clinical/ lab variables that allow us to recognize when critical O₂ delivery has been reached. Oxygen requirements are increased in shock. Rising lactate levels (reflecting anaerobic metabolism) are possibly our best available indicator.
- Young healthy subjects (like parturients) can compensate for a blood loss of 30–40 % of blood volume. They can maintain their BP until they are on the brink of CVS collapse.
- More than 40% blood volume loss (Grade IV) is life threatening, decompensated shock. Need blood and prompt surgical intervention.
- The response to initial fluid resuscitation is a guide regarding the need for blood. ATLS teaching recommends commencing blood if there is no or only transient response to a 2 litre crystalloid bolus.
- The coagulopathy in head injured patients is due to the release of CNS tissue thromboplastin. This has a poor prognosis, severity inversely proportional to GCS. Platelet count is the least affected parameter in head injury.

Management of Severe Blood Loss

Priorities

Restore blood volume to maintain tissue perfusion and oxygenation:

- Oxygen delivery $DO_2 = C.O. \times SO_2 \times [Hb] \times 1.34 \approx 1000\text{mls/ min}$
- Dissolved O₂ content ($PO_2 \times 0.003$) accounts for very little in terms of O₂ transport.
- The main factors the anaesthetist can manipulate are C.O. by volume loading and increasing the [Hb] with transfusion. Volume loading shifts the vascular function curve to the right and increased cardiac output results courtesy of the Frank-Starling relationship. An increased F_IO₂ to maximize haemoglobin saturation has invariably been instituted.
- Critical level O₂ consumption approached when Hb=4 assuming healthy subject and other variables remain constant which is rarely the case.
- A hematocrit of 30 constitutes the ideal rheological conditions for oxygen delivery.

Achieve haemostasis by:

- Surgical interventions to stop the cause of bleeding
 - Compression/ suture/ embolisation/ immobilisation fracture
 - Specific measures e.g. PPH – empty uterus, prostaglandins, internal iliac artery ligation, hysterectomy
- ‘Correcting’ coagulopathy with appropriate use of blood products. Remember banked blood products even if given in a 1:1:1 ratio can never *normalize* your coagulation profile. In the context of a massive transfusion giving a whole blood equivalent still will not give you a platelet count above a hundred or a hematocrit greater than thirty but it will give you adequate clotting factors.

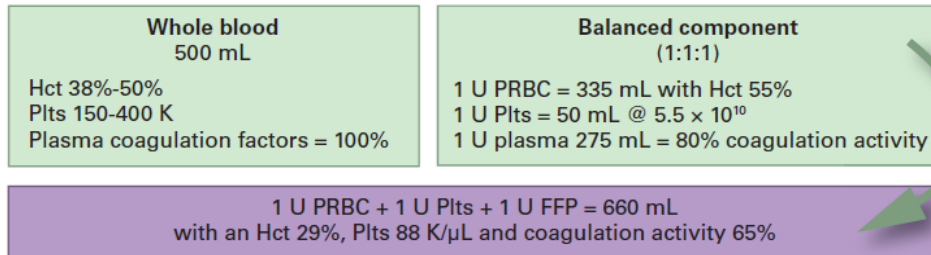

- Prevention of delivery related errors – “spaghetti syndrome”, separate blood and drug lines.

Requirements

- Early consultation with the blood bank. The main role of a massive transfusion protocol (see below, apologies for the appalling layout and colour scheme) is to facilitate the timely supply of appropriate blood products.
- Surgeon with necessary expertise
- Extra anaesthetic assistance
- Large bore IV access and rapid infuser- a rapid infusion cannula is ideal and easy to insert. It is the only intravascular access device that does Poiseuille’s law justice- it is short and wide. You need at least a 20g cannula and a decent vein to feed the wire into it.
- Fluid warmers/ forced air warmers- often need two to cover all the exposed areas. It is impossible to overheat these people.
- ? Cell saver
 - Need at least an anticipated blood loss of a litre for it to be worthwhile. The main problem with a cell saver is that you need a dedicated person to run it and it is often forgotten in the frenetic resuscitation environment. There are very few contraindications for its use.
- Intensify monitoring- Arterial line, temperature probe, IDC for urine output, Echo and others.
- Investigations are to guide therapy:
 - FBE/ PT/ APTT/ fibrinogen/ ABG’s/ U&E’s/ Calcium
 - Care re sampling error
 - Thromboelastography (TEG) and ROTEM are point of care devices that require training to use them correctly. Their application is as tools to measure coagulation status and guide therapy.
 - Reassess regularly until the patient is stable. Clinical assessment is what we are predominantly reliant upon.

Massive Transfusion Protocol Toowoomba Hospital

Blood Bank Responsibilities



Blood Products- Transfusion therapy

There remains a pervasive idea that giving blood must be a good thing to do. There is no evidence to support this in the majority of occasions where blood is given. Transfusion therapy has never been subjected to a clinical trial. There are no perioperative RCTs on blood therapy and there probably never will be. This doesn't help dispel the myth that 'transfusion saves lives'. There are only three significant trials on the use of blood- all compare a restrictive versus a liberal strategy as opposed to blood versus something else and none find a benefit with a liberal strategy. All were published in the NEJM. Here is some detail about these trials:

TRICC is the best known (NEJM 1999; 340:409-17). Transfusion requirements in critical care trial randomized 838 patients to ICU without evidence of active bleeding to restrictive (Hb >7g/dL) or liberal (Hb>10) transfusion strategy. In hospital mortality was reduced in restrictive group but no different at 30 days. Subgroup analysis found no difference in mortality in patients with CVS disease. These accounted for over a third of the cohort. The incidence of cardiac events was the same overall but reduced in the restrictive group while in the ICU.

TRISS (NEJM 2014; 371:1381-91) is the Transfusion Requirements in Septic Shock trial and similarly randomized almost a thousand patients in ICU with septic shock to a restrictive (<7) vs liberal (<9) transfusion strategy. There was no difference in mortality or secondary outcomes. Importantly they excluded patients with myocardial ischaemia. No difference in patients with chronic CVS disease.

The Transfusion Strategies for Acute Upper GI Bleeding trial was conducted in a Spanish hospital. (NEJM 2013; 368:11-21) This is the only major trial to include actively bleeding patients. This trial found a significantly reduced mortality at 45 days with the restrictive (Hb>7) strategy. There were fewer cardiac complications in the restrictive group.

All these trials have problems. For example in the GI bleeding trial all patients underwent gastroscopy within a mean of 5 hours of presenting to hospital. It is unrealistic to expect this in a real world setting!

While most editorialists put a caveat on the patient with active myocardial ischaemia the best available evidence suggests to me that these patients are even *less* likely to benefit from a liberal transfusion strategy. We know that the older blood is, the more deformed the erythrocytes are and the more depleted in 2,3 DPG it is. The ability to improve oxygen delivery is severely diminished. Optimizing cardiac output is a better strategy to improve oxygen delivery.

Case control and retrospective studies all overwhelmingly find improved outcomes when blood is not given or a restrictive strategy is employed. CABG and acute coronary syndrome trials (GUSTO had over 40,000 pts) also correlate worse outcome with the administration of blood. We are also aware of the association between transfusion and higher rates of cancer recurrence and infection. This is attributed to transfusion related immunomodulation (TRIM). Transfusion is a profoundly immunosuppressing event.

A diagram worthy of consideration

This diagram comes from a paper that describes a computer model demonstrating what would happen to prothrombin time (PT), fibrinogen concentration and platelet count in the event of massive bleeding without replacement of clotting factors or platelets. The term blood volume could be interchanged for bleeding fraction on the x-axis. The paper is frequently cited in review articles on massive bleeding and trauma management. The dotted lines refer to the threshold value at which you would expect to see clinically important coagulopathy related to that component deficit alone. The take home message is that you would expect clotting factor loss to be a problem after one blood volume loss whereas thrombocytopenia shouldn't be a problem until two blood volume loss. Like any model it has numerous limitations but it has been validated by limited real world data.

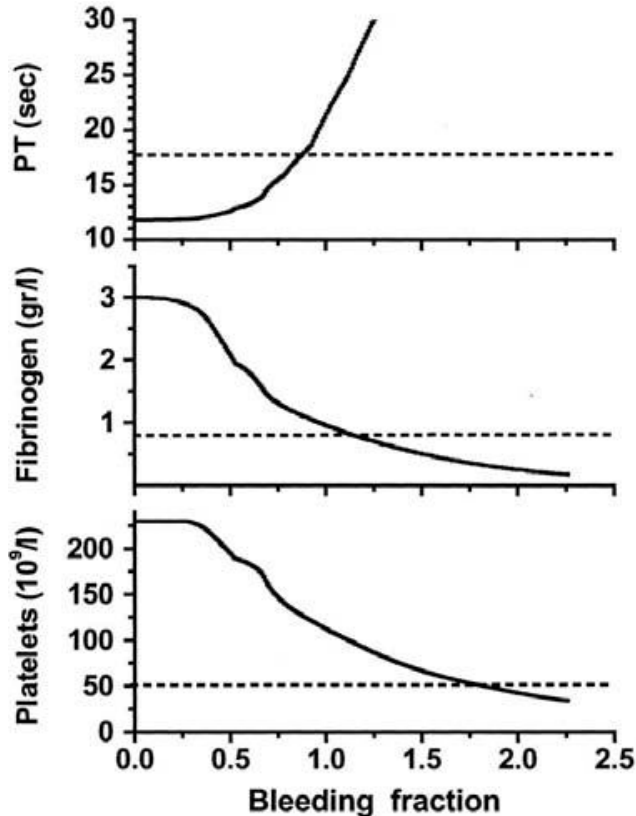

Specific Blood Component Therapy

Packed Red Cells

- O negative is used in the extreme event that you must give blood *now*.
- One unit is about 300mls and will increase Haemoglobin by 1g/dL if they have a normal BMI. It costs about four hundred dollars a unit just for the manufacturing costs.
- Group specific then 'cross matched'. Human error is still the commonest cause of giving an ABO incompatible transfusion which is the commonest cause of a major haemolytic 'transfusion' reaction.
- The infective risks of blood are negligible now. TRALI is the number one cause of death that is directly attributable to transfusion therapy. Many experts very reasonably claim that TRALI has killed more people than have been saved by transfusion.
- Beware human error when checking/ giving blood- all blood must be checked by two individuals before giving in any circumstances.

Platelets

- Expect <50 after 2x blood volume replacement (as per above diagram)
- Aim for >100 in multitrauma/ CNS trauma/ abnormal platelets
- Need to request these well before the anticipated target has been reached. Often platelets are in short supply in the blood bank. They are only stored for five days. They are usually

provided as a polybag which is equivalent to 4 or 5 units. One unit will increase your count by about 5.

- Platelets do not have to be ABO compatible.
- Platelets should not be transfused in the same IV set as blood because this can cause aggregation.

Fresh Frozen Plasma

- Give when PT/ APTT > 1.5 x control (correlates with clinical coagulopathy), i.e. at least one blood volume replacement.
- Dose 15mls/ kg (four units for the elusive 70kg adult). Most labs will thaw this for you and then throw it out if you don't use it. Comes in 200ml bags.
- This needs to be ABO compatible and note it is not the same rationale as packed cells. For example, patients who are type AB negative don't have any anti-A or anti-B antibodies in their plasma and so are universal donors for plasma.
- Subsequent to this with ongoing bleeding – consider giving FFP with blood in a 1:2 volume ratio so that coagulation factor levels are maintained at approximately 30%.

Cryoprecipitate

- Give when Fibrinogen < 1g/L
- Expect after 1.5 x Blood volume loss
- Dose 1 pack (30mls) /10kg bodyweight.

Who do I give blood products to?

Packed red cells: all of these three criteria must be satisfied:

1. The haemoglobin concentration is low by objective measurement and;
2. The patient is actively bleeding and;
3. The bleeding hasn't been stopped yet.

Fresh Frozen Plasma: give to someone actively bleeding a blood volume or more; someone actively bleeding who is coagulopathic on clinical or lab criteria. The surgical field is the best indicator of coagulopathy.

Platelets: give to someone actively bleeding a blood volume or more; someone actively bleeding who has a platelet count of less than a hundred or has dysfunctional platelets. I wouldn't give them prophylactically in any circumstances.

Cryoprecipitate: give as part of massive transfusion protocol with a lower threshold in the pregnant patient with documented hypofibrinogenaemia.

Obviously a bleeding trauma patient satisfies most of the above criteria.

Specific Drug Therapy

- Tranexamic Acid - anti-fibrinolytic and anti-inflammatory drug, proven efficacy when used prophylactically for orthopaedic joint arthroplasty, prostate surgery and to manage VWD. The truly massive CRASH-2 trial on the use of Tranexamic acid in trauma found a modest mortality benefit with its use hence its incorporation into massive transfusion protocols. The dose was 1g in 100mls saline given over ten minutes followed by an infusion of a further gram over eight hours. Interestingly it didn't decrease transfusion requirements. The most benefit was seen when it was administered within the first three hours post

injury. Curiously, when given after this time period, tranexamic acid was associated with increased mortality. The risk of thrombotic complications is reported as being very low.

- Desmopressin- can improve platelet function; established role in VWD; the dose is 0.3 mcg/kg as an infusion over twenty minutes.
- Recombinant Activated Factor VII 'Novoseven'- licensed for use in patients with antibodies to blood factors, widespread off license use in massive haemorrhage.
 - Case reports of stopping bleeding in patients otherwise expected to die.
 - Fabulously expensive, dose range 30-90mcg/kg and repeat once if no response which should be rapid if it is to occur.
 - Efficacy in trauma (conflicting results), established DIC, inadequate surgical haemostasis, post-partum haemorrhage.
 - Has been used in Jehovah Witnesses.
 - Several RCTs- efficacy in blunt trauma, radical prostatectomy, intracerebral haemorrhage. Less bleeding, need for transfusion, trend to decreased mortality. Negative results in liver resection and major pelvic surgery but VIIa given on skin incision.
 - Main adverse effect is thrombotic events- appear to be rare in patients with coagulopathy.
 - Need platelets >100 and fibrinogen and treatment of acidosis (pH>7.2) for this drug to work best. It has a relatively short half life so is not used as a prophylactic agent.
 - Cost means its use is protocol based- usually after significant blood products have been given and despite surgical efforts to stop the bleeding.

SELECTED REFERENCES

An excellent text is *Perioperative Transfusion Medicine* 2nd Ed. 2005 by Bruce Spiess et al. I'd consider this the benchmark textbook resource.

Spiess has written many journal articles, a recent and informative article focusing on RBC use is called Red Cell Transfusions and Guidelines: A Work in Progress, *Hematol Oncol Clin N Am* 21 (2007) 185-200. A fantastic PowerPoint presentation called Blood Transfusions: Risks and Outcomes is available to download from www.HemostasisCME.org

ANZCA has a CPD module about major haemorrhage that is a mandatory requirement.

A good review article titled Coagulopathy and blood component transfusion in trauma by Spahn and Rossaint is in the *British Journal of Anaesthesia* 2005; 95: 1309.

The Australian and American Red Cross have a transfusion medicine manual and guidelines. The latest Australian manual can be downloaded from www.transfusion.com.au

Hemostatic resuscitation, R Dutton, podcast 2011 EMCrit Lecture series

Effects of tranexamic acid on death, vascular occlusive events, and blood transfusion in trauma patients with significant hemorrhage (CRASH-2): A randomized, placebo-controlled trial. CRASH-2 Collaborators. *Lancet* 2010; 376: 23-32.

Minimizing dilutional coagulopathy in exsanguinating hemorrhage. A computer simulation. A Hirshberg et al. *J Trauma* 2003; 54: 454-463.

LIGHT RELIEF

**Warning- product not
licensed**

THIS PRODUCT IS NOT FREE- COST \$400/unit

**THIS PRODUCT IS KNOWN TO CAUSE THE FOLLOWING ADVERSE EFFECTS
WHEN ADMINISTERED:**

- Immunosuppression
- Fever, allergic reactions including anaphylaxis
- Disordered coagulation status
- Hypothermia unless warmed
- Adverse cardiac events
- Kidney injury
- Lung injury which may be fatal
- Infectious hazard- bacteria, viruses, protozoa
- Impaired oxygen carriage

BEFORE ADMINISTRATION ENSURE THAT YOU HAVE:

- Considered alternative, safer products
- Checked with another clinician that it is compatible for the patient
- Confirmed the patient has [Hb]<7 at a minimum
- Excluded a chronic disease state
- Advised the patient of the above risks and lack of efficacy of this product
- Advised the patient that they will have the same or possibly better outcome if they *do not* receive the product

User agreement:

I have read and understood the above and still want to proceed with this organ transplant

NAME _____ DESIGNATION _____ DATE _/ _/ _

**Please dispose of this toxic product in a suitable
Biohazardous Waste container**

Making a Difference

I think I can reasonably assert that we all want the best for our patients. Ultimately it is outcomes that are important: the avoidance of adverse outcomes tends to overshadow the desire for good outcomes as far as the medical literature and hospital administration is concerned. Practically speaking we are all very interested in achieving the positive outcome of the patient having had their procedure and leaving recovery without event. Finishing the list on time, although undoubtedly important, is a very egocentric outcome. The patient wants to have their operation safely without complications. We can't guarantee a perfect outcome of course but we should strive towards this ideal. Death and major morbidity is fortunately rare. Patients don't die on the table; they die two days later on the ward or when they have gone home. An adverse outcome that is of great importance is surgical site infections (SSI). As well as causing pain and suffering these are a huge cost on the health system as they incur prolonged inpatient stays and often further invasive procedures. The anaesthetist has an important role to play in minimizing the incidence of these. In 2007 (when I was younger and almost idealistic) I gave a presentation to my Department called 'Making a difference'. I compiled a list of interventions that I thought were worth pursuing. They are listed below:

1. Use pre-warming to prevent hypothermia
2. Use high FIO₂ perioperatively for bowel resections
3. Follow guidelines for the use of prophylactic drugs in PONV
4. Use chlorhexidine instead of betadine as skin prep
5. Ensure patients remain on their low dose aspirin throughout the perioperative period
6. Reduce errors by the use of: cognitive aids, checklists, peer review, avoidance fatigue, automated records/ barcode system
7. Aggressively treat/ use techniques that avoid hypotension
8. Don't transfuse your patient (unless they *really* need it)
9. Have your own GP and see them, get married (and don't get divorced), eat well, exercise regularly and drink in moderation. (We won't consider this last point as although very important it relates to your personal health, not the patient's.)

The year is important because quite a few pivotal studies on several of the topics were conducted over the subsequent years. Indeed in 2015 I gave a presentation with the same title and spent the first half of the talk acknowledging that trials had failed to support points 2 and 5 (PROXI, ENIGMA 2 and POISE 2), point 4 only related to skin preparation for CVL insertion and although point 7 was a strong association it is still hard to prevent in the first place. 'The induction of anaesthesia is a stress test and the hypotensive patient is failing it.' Point 1 only had utility in the Queensland winter and point 3 had led to the almost universal use of dual agent anti-emetic prophylaxis. A lot of activity was conducted with relation to point 6, the most notable example being the worldwide rollout of the WHO Surgical Safety Checklist. Unfortunately its application in the local setting hasn't translated into improved outcomes but has certainly exacerbated delays in the time it takes to get a patient actually into theatre. I believe point 8 has strong merit and the case is presented in *The bleeding patient and transfusion therapy*. Being left with not much that I could apply to my current practice I searched elsewhere. I found

an article by Landoni et al published in 2012 that listed evidence based interventions that decreased perioperative mortality. Looking at non-cardiac surgery they listed five interventions:

1. Clonidine
2. Neuraxial anaesthesia
3. Perioperative haemodynamic optimisation
4. Perioperative supplemental O2 (colorectal)
5. Selective decontamination of the GI tract

Again large trials have refuted the efficacy of the first four interventions to reduce mortality. Most of them are described in *Studies you should probably know about*. Point 5 is supported by small trials only. The power, pun intended, of large clinical trials is that they often don't replicate the positive findings of small trials when the intervention is implemented on a large scale in a variety of settings. In fact if you look at perioperative mortality data for the last decade it is noteworthy that it has not improved at all. We are better at treating heart attacks, strokes and cancer but people are still as likely to die after surgery. This led me to iterate the point that was the conclusion to my first 'Making a difference' presentation. As anaesthetists we need to do the 'little things' correctly and consistently. What do I mean by that?

What we do already

The following items have a wealth of evidence to support them and everyone is agreed that they are important.

- Maintaining normothermia and normoglycaemia.
- Giving perioperative antibiotics appropriately- the correct drug at the correct dose in the optimal timeframe.
- Quality postoperative analgesia- it doesn't matter how so much as achieving the target of a comfortable patient who is being monitored appropriately.
- Operating on people who will benefit from their surgery- this is an issue of surgical selection which is largely out of our zone of influence. We might not be the gatekeepers but sometimes we are compelled to exercise common sense when other health professionals have failed to do so. It is important to accept that our ability to alter the risk profile of the high risk patient is minimal. As I said earlier in this book, the only way to avoid the risks of an operation is not to have it.

The first three items should be done consistently well. They are entirely within our realm of control. If a patient having a knee replacement gets a wound infection it is a disaster. However, if the patient is morbidly obese, smoking, on a fentanyl patch and has poorly controlled diabetes then they are facing an uphill battle before we have even touched them. A morbidly obese patient will benefit more from a gastric sleeve operation than a joint replacement.

What we can do

The above discussion leads to the inevitable and disheartening realization that our ability to influence clinically important outcomes by instituting changes in intraoperative care is very limited. We shouldn't give up, though! I believe it is in the early postoperative period where improvements can be made. This is where the role of the anaesthetist as perioperative physician is being increasingly championed. Sepsis probably kills more surgical patients in hospital than

any other disease process. Late recognition of the critically ill patient and late institution of appropriate therapy leads to bad outcomes. Often the complexities and challenges of postoperative care devolve to the most junior medical officer in the treating team. ERAS like programs (Enhanced Recovery After Surgery) consistently report improved outcomes. These programs don't incorporate some magic intervention; they are the product of several important aspects I have listed below:

- 'Buy in' by perioperative staff- the very fact that a team chooses to institute an ERAS program reflects that they are interested in improving outcomes. Sometimes changes don't even need to be made, the process of looking at the problem can lead to improvements in itself.
- Evaluation and implementation of best practice- to devise a program requires evaluation of the best quality evidence. Invariably the problems you have are not unique and you should benefit from the efforts of others.
- Comprehensive and focused preoperative assessment- a thorough assessment is the foundation for a successful perioperative journey. It also allows for preoperative optimization of the patient- investigating and treating anaemia for example, not sticking a pulmonary artery catheter in them!
- Consistent and coordinated practice- instead of everyone doing their own thing, everyone is doing the same thing at the same stage. This leads to less confusion and ease of comparison by reducing the number of variable factors.
- Defined goals and outcomes- it is important to know what you want to achieve. Targets need to be defined and met. Sometimes you have to make things happen; don't just expect them to.
- Senior personnel involvement- experience is an invaluable resource that can't be bought. If you want the best outcomes you need to have the best people working towards them. The intern is not the expert on assessing the postoperative course of a patient.
- Ongoing audit and review of practice- if you don't measure outcomes you won't know if you are improving or not.
- Enhanced teamwork and communication- having everyone on the same page and giving permission for individuals to interact with each other can only help the cause. If the physiotherapists, occupational therapists, dieticians, pharmacists, nurses and doctors don't talk and engage with each other then this sorely limits the chances of achieving shared goals.
- Recognition that the anaesthetist has something to offer outside of the theatre- acute pain services in many ways function in a broader perioperative medicine role albeit often by default. Anaesthetists are skilled at recognizing sick people as well as diagnosing and treating acute illnesses. Our expertise extends beyond pain management to encompass oxygen therapy, anticoagulation and diabetic medication management, prescription of fluids and vascular access.

None of the above aspects are particularly difficult or complex. What they do demand however are two resources that are very valuable and in short supply: time and experienced personnel. Many hospitals are reluctant to invest these resources into ERAS like programs. The concept of an anaesthetist doing something useful outside of the theatre remains foreign to many surgeons

and medical administrators. Anaesthetists should advocate for and be actively involved in these programs. This is the way forward if we want to improve outcomes for our patients.

CHALLENGE QUESTIONS- JUMBO SET

1. An oxygen cylinder contains compressed gas and a Nitrous Oxide cylinder contains liquid and gas (vapour actually). What is in a cylinder of Entonox?
2. What two volatile agents could you theoretically use separately in the same vaporizer and the concentration dial setting would still read correctly?
3. What is the so called 5th vital sign?
4. If you wanted to use x-rays to confirm the correct position of an endotracheal tube; how many would you have to take? (I accept this is not a practicable method.)
5. Can you give O negative plasma to a patient who is A positive?
6. What is the smallest cuffed tube you can use in an adult?
7. Can you insert a LMA in a patient in the prone position?
8. If you turn your head to the left, where does the right internal jugular vein lie in relation to the carotid artery?
9. Dr Mark Lidwill was a famous Australian anaesthetist who died in 1968 at the age of ninety. What notable invention is he credited with?
10. You have just finished anaesthetizing a patient who is HIV positive. Do you need to change the anaesthetic circuit for the next patient?
11. What is significant about the 16th October, 1846?
12. Who is the most cited author in the anaesthetic literature?
13. How do volatile anaesthetics work?
14. William Russ Pugh is credited with giving the first anaesthetic for a surgical procedure in Australia. He used ether in a device which he constructed based on an illustration in a London newspaper. In which town did he give the anaesthetic?
15. What does the College motto *Corpus curare spiritumque* mean?

ANSWERS

1. Entonox is a 50:50 mix of oxygen and nitrous oxide and is a gas courtesy of the Poynting effect. The Poynting effect refers to the interaction between a gas and a liquid such that the vapour pressure of the combination is altered. A complex formula describes the relationship. Entonox has a pseudocritical temperature of -6 degrees Centigrade. At this temperature nitrous liquefies and so an oxygen rich mix will be given off initially until this is exhausted and then it becomes an oxygen poor mix!
2. The key index system prevents filling a vaporizer with an agent not intended for it. However, theoretically halothane and isoflurane could be used interchangeably as they have very similar saturated vapour pressures of approximately 240mmHg at twenty degrees. The splitting ratios are pretty much identical. You would have to know which agent you had used though because although the indicated concentration is correct the MACs for these two agents are different.
3. A pain score is the fifth vital sign. Some may argue that a pain score is very subjective but unfortunately that's about as objective as we can be for this criterion.
4. You would need to do an AP *and* a lateral film as the trachea overlies the oesophagus.
5. No. O negative is the universal donor for red cells but AB negative is the universal donor for plasma as patients with blood group AB have no antibodies in their plasma. O negative plasma contains anti A and B antibodies which can cause lysis of recipient red cells if transfused.
6. The smallest cuffed tube suitable for an adult is a 4.0 microlaryngeal tube (MLT). Smaller cuffed tubes exist but they are too short for use in an adult. A MLT tube is actually longer than a regular ETT.
7. Of course you can and there are large case series of this exact thing. It is easiest to do with the patient turning their head to the side having positioned themselves on the operating table lying on their stomach. If they are facing the floor then fixation of the LMA is an issue. I wouldn't recommend this technique to the *first year* trainee. Don't have the patient trolley too far away (so you can flip them on their back).
8. Instead of being lateral to the artery you will find, when you stick an ultrasound probe on the neck, that the vein will be lying directly on top of the artery. This has obvious implications for central line insertion technique.
9. Dr Lidwill is credited as the inventor of the artificial pacemaker. He devised an apparatus and used it to effect on a baby with heart block in 1926 in Sydney's Crown Street Hospital (where the author was born incidentally). He invented several pieces of anaesthetic apparatus and is also the first person noted to catch a Black Marlin with a rod and reel!

10. No, although this is often done. The HME filter prevents passage of viruses.
11. This is arguably the most significant date in modern medicine. This is the date of the first successful demonstration of anaesthesia by William Thomas Green Morton using ether at the Massachusetts General Hospital in Boston. In recent years the date has been celebrated annually as 'World Anaesthesia Day'. Every anaesthetist should know this!
12. Edmond Eger (1930-) is the most cited author. He has over 600 articles to his name and several of the most cited articles in the anaesthetic literature. He is most famously known as the father of MAC. His original article was published in 1963: G Merkel and E Eger. A comparative study of halothane and halopropane anesthesia: Including a method for determining equipotency. *Anesthesiology* 1963; 24: 346-57. Possibly his most interesting paper relates to the uptake of volatiles by several animals including a baby gray whale which weighed six tonnes. The most cited article in the anaesthetic literature as of a 2011 study was by R Melzack. The McGill Pain Questionnaire: major properties and scoring methods. *Pain*; 1975.
13. It is the great mystery of anaesthesia. We still don't really know. Not even Dr Eger. It is certainly complex and involves multiple molecular targets.
14. It was in Launceston on June 7, 1847. There is a statue there which commemorates the event. It is still contentious who actually gave the first anaesthetic in Australia. Gwen Wilson's book, *One Grand Chain*, is the definitive resource about the topic.
15. 'To care for the body and its breath of life'.

Miscellany



A sleeping *Giraffa Camelopardalis*

My Top Twenty Tips

1. If you're wondering whether you should tube the patient then you should tube the patient.
2. The most useful monitor for a sick patient is an arterial line.
3. Practice bagging every patient before you stick an LMA down- you'll be glad you've honed this skill when you have a failed intubation.
4. Treat your anaesthetic assistant with courtesy and respect; they are your most valuable resource when you are by yourself.
5. Ejection systolic murmurs in #NOF patients are severe aortic stenosis until proven otherwise.
6. Position the table in reverse Trendelenburg for the obese patient on induction.
7. Always give reversal unless you've got a good reason not to.
8. Try new techniques/ gizmos on elective lists when a consultant's around- not at night during an emergency.
9. Have (and practice) a backup technique for when the LMA doesn't fall in eg. Bougie guided technique.
10. Keep your anaesthetics simple- don't give yourself too many opportunities to make mistakes.
11. Don't trust an IMED line- start a new drip with a standard giving set and make sure it runs before giving *any* drug through it.
12. Stridor at rest = trache under local.
13. You should be able to put a central line in without an ultrasound machine.
14. The sucker has only two purposes: sucking stuff and stimulating the patient. If there isn't stuff to suck you must be stimulating the patient.
15. Blood loss is invariably underestimated, have a low threshold to do a hemocue.
16. High airway pressures always have a cause- you should find out what it is.
17. If you do the same thing a hundred times you should get pretty good at doing it. There is no substitute for experience.
18. If in doubt- ask.
19. The drug you are most likely to kill someone with is propofol. The older and sicker the patient- the more slowly you give it.
20. Read my book- it's full of useful stuff.

The Cost of Things

Listed below are an assortment of drugs and disposables and their price for a single item. The prices are current at the time of writing but they are always changing. Nonetheless they are illuminating and worthy of perusal. A few have a brief comment because I can't resist the temptation to make a point.

Volatiles

Desflurane bottle \$230

Sevoflurane bottle \$125

Isoflurane bottle \$84 Although the cheapest by far especially when you correct for potency, Isoflurane is on a par with thiopentone in terms of the limited exposure most trainees have to this drug. Unlike propofol, desflurane has very limited advantages over isoflurane considering you are paying approximately ten times as much for it.

Analgesics

Fentanyl 100mcg ampoule \$1

Alfentanil 1mg ampoule \$4

Morphine 10mg ampoule \$1

Oxycodone 10mg ampoule \$2.50

Remifentanil 1mg ampoule \$14 Five minutes after you switch it off and it's all gone.

Tramadol 50mg tablet 6c

Ibuprofen 400mg tablet 9c

Parecoxib 40mg ampoule \$18

Paracetamol 500mg tablet 1c

Paracetamol 1g IV \$2 seems a big premium to pay for something that the patient could have swallowed for a hundredth of the cost

Heavy Marcain spinal ampoule \$16

Ropivacaine 20ml 0.75% ampoule \$3

Lignocaine 2% with adrenaline 20ml ampoule \$27 Local anaesthetic solutions containing adrenaline are way more expensive than plain solutions.

Anti-emetics

Ondansetron 4mg ampoule 39c

Metoclopramide 10mg ampoule 46c Still cannot think why anyone would use this drug...

Dexamethasone 4mg ampoule \$1

Vasopressors

Ephedrine 30mg ampoule \$18 all expensive drugs

Metaraminol 10mg ampoule \$40

Phenylephrine 10mg ampoule \$18

Miscellaneous Drugs

Midazolam 5mg ampoule 62c

Propofol 200mg ampoule 80c

Cephazolin 1g ampoule 60c
Cefoxitin 1g ampoule \$14
Rocuronium 50mg ampoule \$2.40
Atropine 1200mcg ampoule \$1
Glycopyrrolate 200mcg ampoule \$7
Flumazenil 0.5mg ampoule \$100 I think you'll find the most expensive drug kept on an anaesthetic trolley is this stuff.
Sugammadex 200mg ampoule \$130 which is the reason why they don't keep this on the anaesthetic trolley! (When first released it was a dollar a milligram.)

Equipment/ Disposables

Standard ETT \$2.50
Reinforced ETT \$18
Microcuff ETT \$15
Size 5 Supreme LMA \$20
Size 5 Classic LMA \$9
Size 5 Igel LMA \$16
Size 5 Proseal LMA \$260
BIS electrode \$20
Warming Blanket \$11-\$22
HME filter \$2.50
Facemask \$2
Spinal needle \$13
ALARIS PK pump \$4000

Unless you are drawing up vasopressors routinely and are a big fan of parecoxib, the cost of consumables greatly exceeds the cost of your drugs for the majority of anaesthetics. Of course the cost of surgical consumables makes our expenses pale in comparison.

Preparing for the Primary Examination

An approach to the exam

I don't need to tell you that the primary exam is a tough exam. The pass rate is around fifty percent and this has remained consistent over the decades. It is essentially a book exam, i.e. you have to transfer a large amount of content from a book to your hippocampus. But it also tests your understanding of the content especially in the viva component of the exam. You also need to be able to think on your feet. It takes most people between 12 and 18 months to prepare for the primary. I don't recommend taking lots of time off to 'study'. My experience is it doesn't help but merely identifies people who aren't organized. People fail because they didn't know straight forward stuff that they themselves admit they should have known. Knowledge deficit is the core issue in the vast majority of failures. Poor exam technique will certainly exacerbate matters.

You should talk to at least three different people who've done the exam relatively recently. Look through their pile of stuff and get their perspective on it. It is nice to study in a group, more for mutual support than anything else.

Physiology has a lot of conceptual elements to it and you need to have a sound grasp of these to succeed. Reading the core texts helps in this respect. Exam primers (Brandis aside) aren't good at explaining concepts. Pharmacology is more of an exercise in rote learning.

The single most useful exercise for me was to research and write my own answers to a whole pile of past SAQs and viva topics. I would recommend using the "Opening Question" for the vivas on the exam reports as the starting point for your list. This took me the best part of six solid weeks and I couldn't start until I'd read the core resources which are described below. To write your own answer means you have to read, process and reproduce information yourself. It is a good means of imprinting your hippocampus. Because it is all exam based it is all totally relevant.

Cards: a lot of people make their own set of index cards for pharmacology. Again the most useful aspect of compiling cards is that it forces you to process information and reproduce it in a form that is familiar to you.

The common problems that are associated with exam failure

Not organizing yourself- if you don't have a study plan or don't stick to one if you have, you will fail. I took five months from when I started studying to sitting the written exam and I was working in general practice in Western Queensland. I share this anecdote to demonstrate that if you are organized and focussed you can achieve a lot. Everyone's approach and learning style is different. I divided up the curriculum into big chunks, eg. cardiovascular physiology, cardiovascular pharmacology, cardiovascular clinical measurement and gave myself a month to cover each large chunk. Then I left myself a month at the end to just revise everything but not introduce any new material.

MCQs- not working the Bank, not finalizing an answer for 'new' or recently asked MCQs. Roughly half of them are repeated and half are new. You need to do well on the 'repeated' questions because everyone does badly on the new ones.

SAQs- the commonest crime is not answering the *question that is asked*. Poor handwriting and not attempting all the questions are just as bad. I guarantee you will get more marks writing short relevant notes for every question as opposed to a long detailed answer for some at the

expense of little or nothing for other questions. There is so much time pressure that you do not have the luxury to sit and think about what you will write. You need to be immediately jotting down key points. Don't write flowery opening statements, you want to score points. You do not need to 'define or die'. Only define something if the question asks you to do so. Many trainees do not spend enough time practising writing SAQs. This is important and you are also revising the same content that is in the vivas anyway. Practising questions includes getting someone to mark them. If your study partner can't read or comprehend what you've written how do you expect the examiner to mark it?

VIVAs- not doing enough practice vivas. Better you mess these up than the real thing. Practice vivas enable you to find your knowledge gaps, improve your technique and experience different examiner styles.

You need to work through the Black Bank. Concentrate on the last few years especially. You should nail any MCQs that have been asked in the past. These are as close to 'gimme' marks as you will get. You must read the exam reports for the last four years at least. They are all available online. SAQ's are repeated repeatedly! Topics that have been done very badly in recent exams will be repeated in some form soon after. Leave the viva practice until after the written and then you need to be proactive and annoy every consultant (and registrar who's sat the exam) for practice vivas. One a day and I guarantee you'll pass. *This is very hard to facilitate!* Again use the list of opening viva questions from recent exam reports as a checklist: ensure you can answer something for *every* topic listed. Any consultant you work with is fair game to ask for a practice viva. It is part of their job description.

Finally, you must accept that you will never feel completely ready to sit the exam. It is a case of putting in the hard work, organizing yourself, doing practice questions and vivas and you will get through.

A brief word about short courses

Attendance at these expensive courses is not necessary to pass the exam. Don't attend a course unless you're planning to sit the exam soon. Otherwise you will be overwhelmed. You don't want to be learning new content at the course; it should be an exercise in revision. Often good sets of notes are provided at these courses and accessing the best sets can form a valuable reference resource.

Resources

The ANZCA curriculum very explicitly states what the learning objectives are: appendix 2 of the Curriculum booklet pretty much tells you everything you need to know. This maps the learning objectives to the primary exam for each clinical fundamental, professional role and specialized study unit. There is a lot to learn but no doubt regarding the nature of the content. *Every exam question must be mapped to a learning objective in the curriculum and be referenced to a text from the recommended reading list.*

Having a reliable and good set of notes and texts to use as a reference is the first step to preparing for the exam. The resources listed below are my suggested list. There are kilotons of stuff on the net but be wary of information overload and recognize you need to digest some core textbooks and basic concepts first. At a minimum you need to read Berne & Levy (now edited by someone else but known by the former authors), Brandis, West and parts of Nunn

just to begin to understand concepts. Brandis is a good first port of call, its main deficiency being that it is not comprehensive.

Listed below is stuff which I think is *essential core material*. They are all available for purchase online and many of them are in pdf format. You can get your hands on most of these things for free. The ANZCA library has many textbooks available as eBooks or online.

PHYSIOLOGY

Kerry Brandis *The Physiology Viva* – not comprehensive coverage of the field but you need to know everything inside this book. When you first start reading about a topic, Brandis highlights what the important concepts are and the exam favourite material. The six sets of 100 short questions at the back are invaluable for reaming facts into your head.

Brandis also has good sets of short course notes about many other topics including fluids, electrolytes and blood.

Cardiovascular Physiology 10th ed Pappano & Weir- read it through once just to try and understand the concepts. Not the best book but there is no ideal text on CVS physiology.

Nunn's Applied Respiratory Physiology- the chapters on oxygen, elastic forces and lung volumes, anaesthesia, pulmonary ventilation, distribution of pulmonary ventilation and perfusion and exercise are all essential reading.

Just Enough Physiology James Munis- a quirky but invaluable book that gives a firm grounding in fundamental principles as they apply to core cardiovascular and respiratory physiology.

West's *Respiratory Physiology: the essentials*- (not the applied book) this is a disarmingly simple book on initial inspection but is actually full of quite complex stuff. You need to know everything in this book.

Sessler's chapter on Temperature monitoring in *Miller* is the bee's knees.

All the rest of the subspecialties can be selectively gleaned from general physiology texts like Ganong or even better- from Peter Kam's book: *Principles of physiology for the anaesthetist*. This book's stuff on cardiovascular and respiratory physiology is too brief to understand conceptually but it is good for: Neurophysiology, Gastrointestinal, Endocrine, Metabolic, Pain and Maternal/ Neonatal physiology. It is now in its 3rd edition and it is also a recommended text.

PHARMACOLOGY

No one text does it all. I'd buy just one book (something slim) like Peck and Hill *Pharmacology for Anaesthesia and Intensive Care* now in its 4th edition and supplement it with short course notes especially for the core drugs.

It is worthwhile collecting the product information inserts for commonly used anaesthetic drugs.

Eger's chapter in *Miller* on the Uptake and Distribution of Volatile Agents is essential reading.

Anesthetic Pharmacology by Evers and Maze is considered by many to be the single best textbook for pharmacology but I don't find it user friendly.

Pharmacodynamics and pharmacokinetics are plain vile- there are numerous sets of notes and brief books about them but I find it hard to understand at the best of times. For an entertaining and educational read I thoroughly recommend *Gerry's Real World Guide to Pharmacokinetics and Other Things*. It probably isn't the ideal text for the exam however. There is a good set of notes available on the net by Steven Schafer on the topic. Actually pretty much

anything written by Dr Schafer is good. Standard pharmacology texts cover this dry topic well. You can't know too much about propofol! You need to be very familiar with the pharmacokinetics of TCI. There is a good set of articles in the UK FRCA Bulletin by Gavin Kenny about this subject.

BOTH

Miller selected chapters as mentioned above.

Stoelting's Pharmacology & Physiology in Anesthetic Practice 5th edition is pretty good and certainly the best single book to address the bulk of the Primary Exam curriculum. It's main failing is it is a bit light on in some topics especially physiology. It's a good first port of call and deals with the other noncore physiology topics as well as Power & Kam.

Exam primers/ Texts

I own or have at least flicked though just about every one of the multitude of books available on the market. The best ones are:

- *The Anaesthesia Science Viva Book* by Bricker- written for the UK exam so there is some stuff that is not directly applicable but plenty of stuff that is.
- *Physics, Pharmacology and Physiology for Anaesthetists* by Cross and Plunkett- excellent collection of all the diagrams you need to know and some you probably don't. An alternative but just as good book for these diagrams is *Graphic Anaesthesia*.
- *Dr Podcast scripts for Primary FRCA*- best thought of as a supplement to Brandis's book. Certainly not comprehensive but written in a nice Q&A style. Registrars like this book.
- *The Anaesthesia Viva 1* by Urquhart et al- great collection of prac viva questions that is British. This is also a good book for your significant other to use as a reference for practice vivas when you don't have anyone else willing to grill you.

None of these are a substitute for practice vivas by someone who has been there.

Pre-Questionnaire

I often give this questionnaire to trainees in the early stages of the year to get some idea of their knowledge base. It is not an assessment exercise. It also gives them an idea of the style of the IAAC exam which is presented next.

What is the recommended dose of rocuronium when used as part of a modified rapid sequence induction? ____mg/kg

Define ASA Physical Status Classification Grade 4:

What investigations would you order in a well woman presenting for an elective repeat LSCS?

Briefly outline the components of your routine assessment of a patient's airway

What regular medications, if any, should be withheld on the day of surgery?

List 3 possible causes of severe hypotension post induction of general anaesthesia

1. _____
2. _____
3. _____

According to ANZCA guidelines what standard monitoring should be in use for every GA?

List 3 absolute contraindications to a regional anaesthetic technique

1. _____
2. _____
3. _____

Outline the initial management of pulseless VT in an anaesthetized, intubated adult:

List 3 adverse events that are directly attributable to anaesthetic management of a patient

1. _____
2. _____
3. _____

For a 6yo child weighing 25kg nominate the:

ETT and LMA size _____

Maintenance IV fluid rate _____ mls/hr

Maximum paracetamol dose in 24hrs _____ mg

Maximum dose of 0.2% ropivacaine that can be used for infiltration _____ mls

Nominate 3 antiemetic agents and their effective adult dose:

1. _____
2. _____
3. _____

What is the differential Dx for high airway pressures post intubation?

You induce general anaesthesia in a 25yo ASA1 male undergoing MUA #tibia and place a LMA. Shortly after commencement of the procedure you notice yellow fluid coming up the airway tube and from the patient's mouth. Outline your initial management of this situation.

List some pros and cons of a 2nd generation LMA vs 1st gen LMA

PROS

CONS

Which of the following drugs are licensed for use in children?

Oxycodone _____

Tramadol _____

Parecoxib _____

Propofol for sedation _____

Initial Assessment of Anaesthetic Competence- example paper

The IAAC has two components, a short answer written exam and a viva. The College doesn't prescribe the content but the curriculum is quite comprehensive. I put all trainee anaesthetists including PHOs and JCCA GP registrars through this assessment process. The exam is reproduced below. The answers for almost all of the questions can be found elsewhere in this book. Question 5 is consistently done poorly.

WRITTEN QUESTIONS

Pharmacology

1. What is the intubating dose of Vecuronium and how long should you wait before intubating the patient?

_____ mg/kg _____ mins

2. What is the recommended drug and dose for the acute reversal of Warfarin therapy?

3. List four major adverse effects of Suxamethonium.

- _____
- _____
- _____
- _____

4. According to *Therapeutic Guidelines* what is the recommended antibiotic prophylaxis for a patient undergoing laparoscopic cholecystectomy.

5. What is the maximum daily dose of paracetamol that can be given to a 7 year old child weighing 20kg?

_____mg

6. Write down what medications you would chart *postoperatively* for a 100kg ASA1 woman NKDA who has had an elective Caesarean section under spinal anaesthetic.

Physiology/ Anatomy/ Guidelines

1. Draw the Oxygen Dissociation Curve and list 3 factors that push the curve to the right.

2. List some adverse effects of mild perioperative hypothermia.

- _____
- _____
- _____
- _____
- _____

3. What is the leading cause of death directly attributable to blood transfusion?

4. What are the Apfel criteria for PONV.

- _____
- _____
- _____
- _____

5. According to the ANZCA Recommendations (PS18) name 2 patient monitors that must be in active use for every patient receiving a general anaesthetic.

6. Where is the MH kit/ anaphylaxis kit kept?

7. Using ultrasound how can you distinguish between the Internal Jugular vein and the Carotid artery?

Equipment

1. What are the only 2 reliable methods to confirm correct placement of an ETT in the trachea?

(Fail this question and you have to do it all again)

- _____
- _____

2. What size LMA and ETT for a seven year old child weighing 25kg?

3. Regarding NMJ monitoring- what is a PTC, when is it used and how do you interpret it?
-
-

4. Which blade on the C-Mac videolaryngoscope should be used if you are intubating a patient who is a known Grade 3 direct laryngoscopic view with a Macintosh 3 blade?
-

VIVA QUESTIONS

1. Program TIVA pump for me- what if there was malfunction of pump during case, what would you do? Can you use plasma targeting with Schnider?
2. Aspiration- D&C with LMA
3. High airway pressures- obese patient having lap appendix
4. Pharmacological management uterine atony- precautions you would take with each agent.

Notes about the vivas

1. The consistent errors made are not realizing that plasma targeting doesn't work for Schnider despite it being an option on the pump. Little realization that the pump displays the current infusion rate in mls per hour and that this is a good place to default to should the pump die. Coming up with a reasonable option if the patient weighs 160kg will get you bonus points.
2. Usually done quite badly. Errors include- late decision to intubate; applying positive pressure; not applying cricoid; trying to change the patient position; trying to intubate the patient without relaxant. The priority is to stop the aspiration getting any worse in the first instance.
3. Need to describe how you perform the high airway pressure drill and in a systematic manner consider the four components: anaesthetic machine and circuit, airway device, large airways and lungs, chest wall. If you have excluded pathological causes then need to describe strategies that enable the operation to be performed as well as ensuring the patient is being adequately ventilated.
4. Failure to appreciate that further boluses of Syntocinon (often requested by the obstetrician) are not just ineffective but potentially dangerous. Need to be aware of the contraindications for Ergometrine and PGF₂alpha and their adverse effects. Knowledge of the dose and route of administration is important because the anaesthetist is often the only person in the theatre who knows this essential information.

Midyear Checklist for Meeting with Supervisor- JCCA

It is vital to have meetings with your supervisor of training regularly throughout the year. A semi formal midyear meeting is a useful exercise although it is not mandated. Remember that the intention of the JCCA training is for the trainee to be adequately trained to embark on independent anaesthetic practice once the year of training has been satisfactorily completed. You need to think about what caseload you are likely to do. Just as importantly you need to decide what cases you won't do. The more thought given to this meeting the more useful it will be for all parties. *It is very important to determine whether you are 'on track' or not.* You need a definitive, honest assessment from your supervisor in this regard. It is too late to rectify deficiencies at the end of the year.

- Plan at least a forty five minute meeting with your supervisor when neither of you has commitments elsewhere.
- Bring Learning Plan/ logbook with you.
- Make notes
- Volume of Practice:
 - how many epidurals (50 would be nice by end of year)
 - how many LSCS, epidural top-ups, ?any GA CSs
 - how many paediatric cases?
 - Cases in the prone position?
- Independent Practice
 - What Lists/ Cases have you done by yourself?
 - Endoscopy lists- this is the commonest procedure done by GP anaesthetists
 - What crises have you had to manage?
 - Level of supervision to date
- Technical Skills:
 - Airway Skills- Are you proficient with all the videolaryngoscopes and LMAs including the intubating LMA
 - Bougie guided method for LMA insertion
 - Gas induction of children
 - Other skills- central line, art line, femoral n block, RIC, TIVA

- Anything you feel particularly uncomfortable doing.
- Anything you particularly want to achieve?
- Have you read the (this) book twice?

Make a list of goals for the next few months.

Examples may include things like- doing a CS list by self if haven't already; endoscopy lists by self.

Manage elective adult list independently eg gynae, general surgery, orthopaedics.

Have your supervisor watch you do an obstetric epidural to check you haven't learnt any poor habits.

What stuff won't you do- what are your threshold criteria? Age, weight, others. Discuss these with your supervisor to determine if they are reasonable.

Outline management plan for the morbidly obese patient including GA CS- you may not elect to do these cases electively but you will still be stuck with them as an emergency.

My Other Books

There are three and little bits from all three have been used in this book. A brief blurb about each book is supplied below as well as the table of contents. *The Anaesthetist's Companion* and *The Cynical Anaesthetist* are both available on Kindle for a very modest fee.

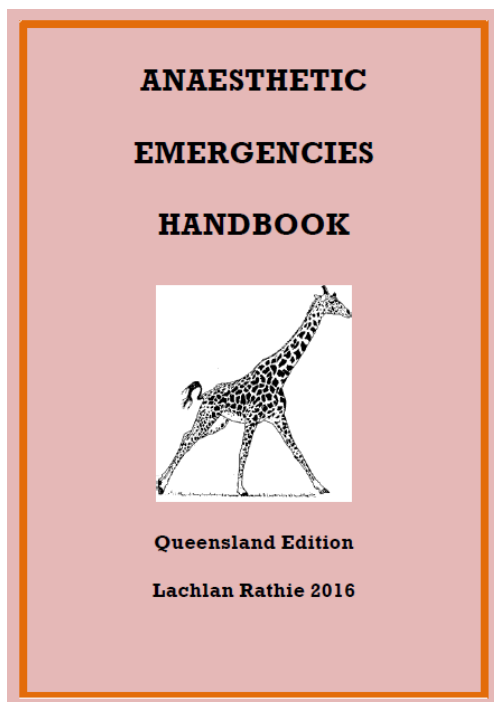

I wrote the first edition of this back in 2007 and have revised it annually since. A couple of years ago I produced a generic version for wider circulation to the Rural Generalist and Queensland trainee community. It is freely available from the ANZCA Library.

EMERGENCY HANDBOOK- CONTENTS

Introduction and References

Crisis Resource Management Principles

Calling for Help

IMPORTANT PHONE NUMBERS/ Accessing AARK

OPERATING THEATRE

- **AIRWAY**

- Approach to difficult airway

- Recognition of the difficult/ threatened airway
 - Formulating a management plan
 - Pros and cons of some techniques for difficult airway management

- Difficult intubation trolley contents/ Airway equipment
 - Surgical airway equipment and Perth Algorithm
 - Paediatric airway equipment
 - D.A.S. algorithms- adult and paediatric
 - Rapid sequence induction, Sugammadex
 - Extubation Guidelines
 - Fiberoptic Intubation notes
 - Laser airway fire protocol
 - Follow up of the patient with a difficult airway
- **CVS**
 - Cardiac Arrest- adult, paediatric
 - Intraoperative tachyarrhythmia
 - Intraoperative myocardial ischaemia
 - Hypotension
 - Hypertension
 - Intraoperative bradycardia-Emergency pacing
 - Air/ gas Embolism
 - Massive haemorrhage
 - Massive transfusion protocol
 - Transfusion reaction
 - The Patient with Pulmonary Hypertension
- **RESPIRATORY**
 - Hypoxia
 - Laryngospasm
 - Bronchospasm
 - Aspiration
 - Double Lumen Tube
- **EQUIPMENT**
 - Power failure
 - Ventilator failure
 - Pipeline O₂ Failure
 - Breathing system disconnection/ leak
 - High airway pressure
 - Intubate but can't ventilate
- **MISCELLANEOUS**
 - Anaphylaxis
 - Delayed awakening
 - Local anaesthetic toxicity
 - Sick laparotomy
 - Raised intracranial pressure
 - Autonomic dysreflexia
 - Malignant Hyperthermia
 - Fire in OT
 - Emergency IV access

RECOVERY

- Acute confusional state
- Severe postoperative pain
- Severe PONV
- Acute respiratory distress post neck surgery

OBSTETRICS

- Postpartum Haemorrhage
- Maternal collapse post epidural
- Maternal Seizure
- Total Spinal
- Failed intubation LSCS

APPENDIX

- EMERGENCY DRUG BOX CONTENTS AND INFUSIONS
- DEFIBRILLATOR
- PERIOPERATIVE MANAGEMENT ANTITHROMBOTICS
- COVER ABCD, SCARE
- PAEDIATRIC FORMULAE
- ANAESTHETIC MACHINE CHECKLISTS
- AIRWAY ALERT PRO-FORMA
- AFTER THE CRISIS PROTOCOL

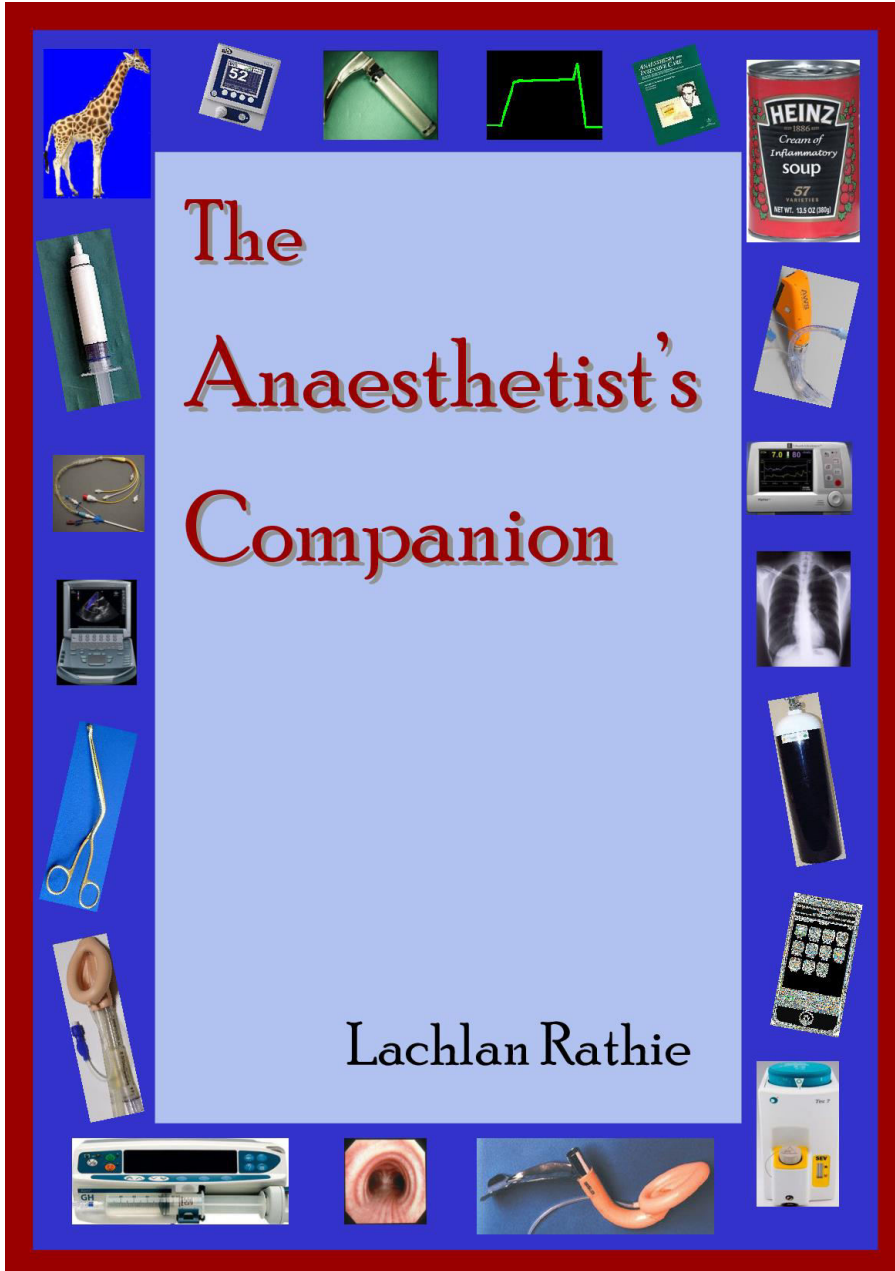

A collection of anaesthetic esoterica. This book is a compilation of assorted nonsense I have written over the years. Its primary purpose is to entertain. Even those not of an anaesthetic persuasion will enjoy it. Each section is brief so you can flick through, pick a little diatribe, and digest it at your leisure. The 'Anaesthetic Shockers' refer to memorable cases I've had over the years.

CONTENTS

Firsts in Anaesthesia
Some Australian Anaesthetic Firsts
Some notable figures in the early days of anaesthesia
Anaesthetic Shockers I
'Hard to kill' patients
Brain Maps
The ASA Score
Stuff Anaesthesia gets blamed for
Collective nouns for assorted medical specialists
Just once I'd like to do the emergency board and not...
Rathie's Guide to Perioperative Cardiac Risk Evaluation
TV Anaesthetists
Ten things you didn't know about Archie Brain and his LMA
Twenty different ways to insert a laryngeal mask
Anaesthetic Shockers II
Things we'd like to hear a surgeon say
Things that can go wrong with an epidural
Anaesthesia, the word
Anaesthesia Subspecialty Algorithm
Perioperative medicine guidelines for orthopods
Revised DSM criteria for the diagnosis of OCD in anaesthetists
Anaesthetic Shockers III
The ANZCA and UK Anaesthetic Crests and the ASA Seal
Giraffes and Neuroanaesthesia
How to anaesthetize a giraffe
How to anaesthetize the monotremes
How to anaesthetize a dolphin
Erudite Endoscopy Exchanges
Anaesthetic Shockers IV
Pitkin's Brachial Plexus Block
The Anaesthetist's Hymn
Introducing the Stupor 3000
Curly questions for anaesthetic novices
How does sux work?
Doctor, I'm allergic to....
Anaesthetic Shockers V
Expensive Care
You k now it's not going to be a good day when...
The Rathie Score
Anaesthetic Shockers VI
How does the BIS monitor work?
Pet Hates
Primary Fellowship Examination report

Final Fellowship Examination Report
Saga of the smellies
Medicare rebate for liver transplantation
Anaesthetic Shockers VII
A few good reads for anaesthetists
PONV treatment options
Anaesthetic Shockers VIII
40 ways to annoy your surgeon
What worries anaesthetists?
Anaesthetic Shockers IX
Why the list doesn't start on time
Top 10 books for the FANZCA
Final exam scenarios from hell
Theatre Sports
Anaesthetic Shockers X
Why anaesthesia is not like flying
A small collection of anaesthesia quirks
Interesting Items Injected Intrathecally
Pirogoff's Pages
Grotto del Cane
Anaesthetic Shockers XI
Roster Rules
What's this used for?
Airway Alert letter template
Twenty top tips
Ten facts I'm surprised most anaesthetists don't know.
Anaesthesia Trivia Quiz
Anaesthetic Shockers XII
Edgar Pask- legendary dude
101 minor disappointments in anaesthesia
Orthopod jokes
Anaesthetic Shockers XIII
Footers

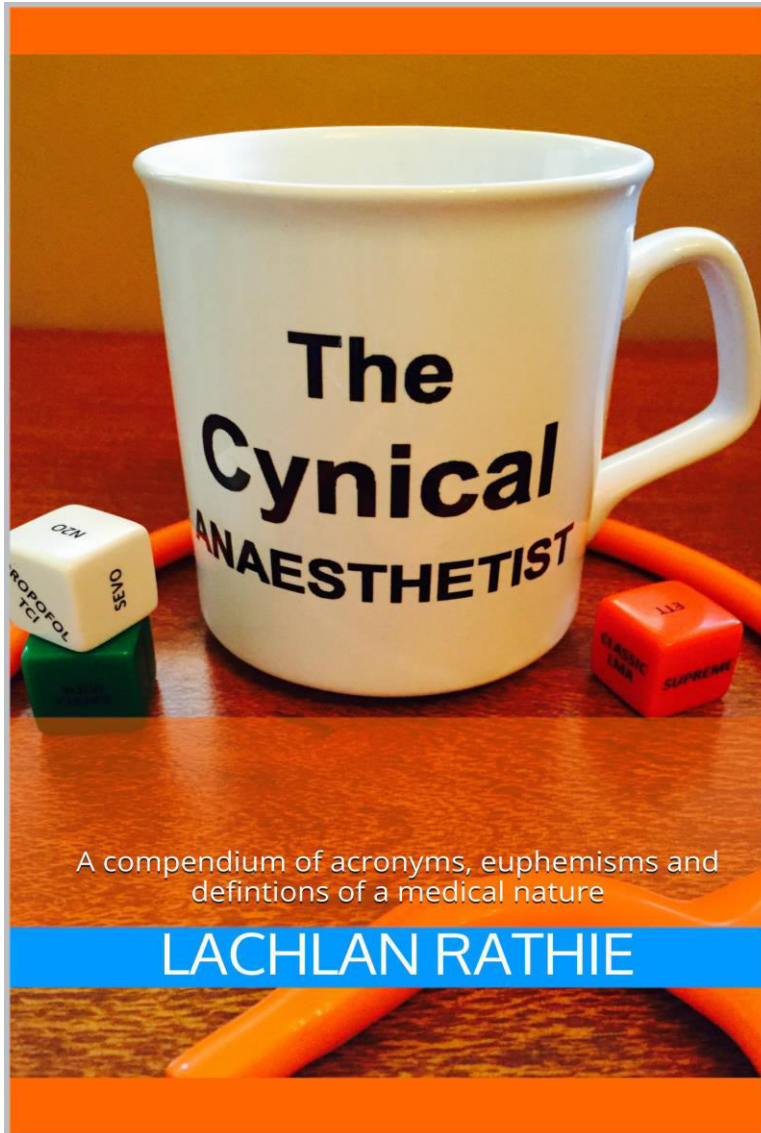

This little book is, as the subtitle says, “A compendium of acronyms, euphemisms and definitions of a medical nature”. I would hope it is the most politically incorrect book you will read this year. The entries are arranged alphabetically. That is my actual coffee mug on the cover.

Selected Excerpts:

ABC of ANAESTHESIA

Airway, Book, Chair

BONE

Hard substance that prevents further passage of a Tuohy needle

COFFEE BREAK

Something you should never refuse

DENTURES

Something anaesthetists remove but never replace

ERCP

Emergency Retrospective Chart Palpation

HAIRCUT

Risk assessment activity, eg. "He's not fit for a haircut"

INTERSCALENE BLOCK

Ingenious method to paralyse half of the diaphragm

LOCUM

Doctor with a personality disorder

NASOPHARYNGEAL AIRWAY

Device used to precipitate epistaxis

PLENARY SESSION

Entertainment you paid a lot of money for

RADIOLOGIST

Doctor who looks at black and white pictures and gives grey answers

SUBPOENA

A dramatic form of patient complaint

TROPONIN LEAK

Euphemism for myocardial infarction

WALKING EPIDURAL

Epidural that's not working very well

About the cover of 'The First Year' and 'The Cynical Anaesthetist'

The cover photos feature some dice I had commissioned for my 'Dice Anaesthesia' folly. I somewhat pretentiously designate this as a novel educational tool. Details about it are in '*The Anaesthetist's Companion*' but the short version is that there are four dice. The red die determines which airway device to use; the green die determines which opioid to use; the white die with black lettering determines how anaesthesia is to be maintained and finally the white die with blue lettering introduces the 'X' factor to proceedings. You can appreciate that it can be quite challenging to actually submit to the fate of the dice depending on what combination results from rolling them.



DICE



AN**A**ESTHESIA

A novel educational tool

Created by Dr Lachlan Rathie

CONTENTS: 4 DIE + INSTRUCTIONS



Some common clinical questions:

- What are the criteria for extubation?
 - What is the intubating dose of rocuronium for a patient who weighs 150kg?
 - How do I interpret a post tetanic count?
 - How do I manage a LMA with a leak?
 - What's the point of giving midazolam on induction?
 - Should I use a cuffed tube in a 4 year old?
 - How do I give a child a TIVA?
 - How do I intubate someone without muscle relaxants?
- How do changes in cardiac output affect the induction dose of propofol?
- Do I have to abandon my anaesthetic machine if there is a power board failure?

This book answers those questions and a whole lot more. It is not an exam primer nor is it a comprehensive textbook of anaesthesia. This is the book you give to the trainee specialist who is about to embark on their anaesthesia training. It contains the information they need to formulate and develop a safe practice of anaesthesia. This book lucidly describes and justifies the core knowledge, behaviours and practice that a junior trainee would be expected to possess after a year of anaesthesia. Written specifically for Australasian anaesthetic trainees and GP registrars doing their JCCA advanced skills post, this book fills the gaping hole in the existing anaesthetic literature. This book aspires to take the relevant bits of a pharmacology textbook, a physiology textbook, a clinical anaesthesia textbook, an anaesthetics emergency manual and a perioperative medicine guide and tie them together in a succinct but sufficiently detailed volume. This book has been written with the intention of being relevant, up to date, pragmatic and entertaining. Written by a former rural GP, now senior staff anaesthetist, supervisor of training and incorrigible cynic; this is the book he would have liked to have when he embarked on his First Year.

Barcode Area

We will add the barcode for you.

Made with Cover Creator